

Thank you for purchasing our inkjet printer JV150 series.
This "Print Guide" explains the printing method using JV150 series and the software RIP [RasterLink] and items to be checked/set before printing.

Note

- It is strictly prohibited to write or copy a part or whole of this document without our approval.
- This document has been carefully prepared for your easy understanding, however, please do not hesitate to contact a distributor in your district or our office if you have any inquiry.
- Description contained in this document are subject to change without notice for improvement.
- Due to improvement or change of software, the description of this document could be partially different in specification, for which your understanding is requested.
- With the exception of what is provided for in the warranty provisions of MIMAKI ENGINEERING CO., LTD., we do not assume any liability against the damages (including but not limited to the loss of profit, indirect damage, special damage or other monetary damages) arisen out of the use or failure to use of this product. The same shall also apply to the case even if MIMAKI ENGINEERING CO., LTD. had been notified of the possibility of arising damages in advance. As an example, we shall not be liable for any loss of the media (works, sheets) made using this product or indirect damages caused by the product made using this media.
- You can also download the latest operation manual from our website.

RasterLink is the trademarks or registered trademarks of MIMAKI ENGINEERING CO., LTD. in Japan and in other countries.

Adobe, Illustrator, Photoshop are the trademarks or registered trademarks of Adobe Systems Incorporated in the United States and other countries.

Other company and product names mentioned herein are the trademarks or registered trademarks of the respective companies in Japan and in other countries.

Unauthorized reproduction of any portion of this document is strictly prohibited

Please prepare before use.

Before printing, the preparation for the printer and the software RIP [RasterLink] is required.

About system configuration. (Refer to P. 3)

The explanation of the system configuration to print is described.

Prepare the printer. (Refer to P. 4)

This section explains how to prepare the printer.

- Connecting a PC installed RasterLink to the printer.
- Adjusting the head height.
- Set the media.
- Test print
- Feed rate correction (Media correction)
- Ink drop position correction (Dot position correction)

Prepare the Mimaki Driver. (Refer to P. 5)

Install Mimaki Driver.

Prepare the RasterLink. (Refer to P. 5)

The preparation of RasterLink is explained.
For the installation method, refer to the "Installation Guide" of the RasterLink.

The printing method using a sample is explained.

Prepare any image data, or sample images on the attached CD.

Perform printing. (Refer to P. 7)

Download the profile suitable for the using condition. (Refer to P. 9)

Frequently asked questions.

Typical questions. (Refer to P. 11)

Preparation before use.

About system configuration.

Instruct to print the printing data created with the application such as Illustrator or Photoshop etc. from the PC in which the RasterLink has been installed.

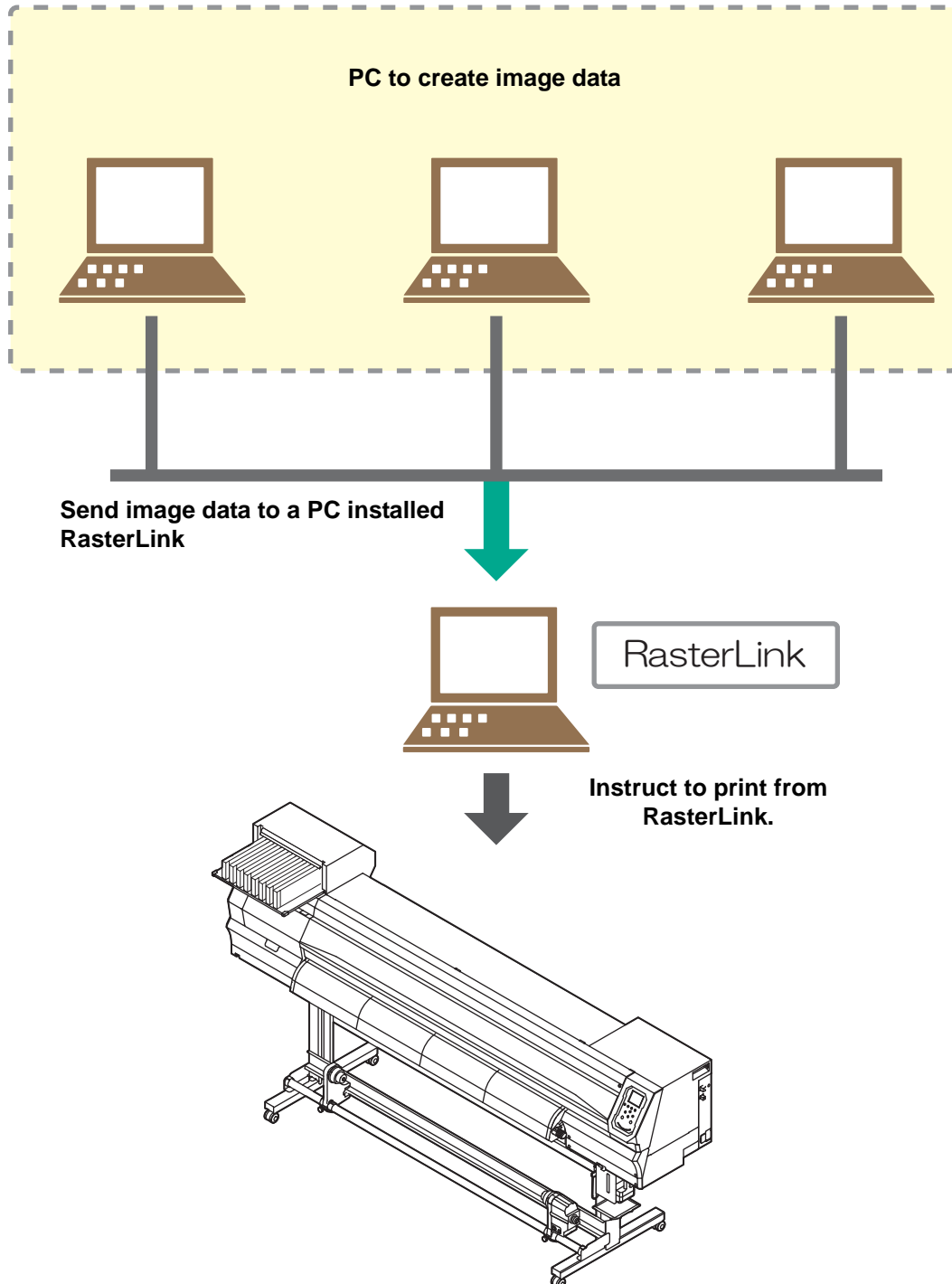

Prepare the printer.

Following the procedures below, prepare the printer.

1. Connect the PC installed RasterLink to the printer.

- For details, refer to [Chapter 1 “Connecting Cables” of the printer "Operation Manual"](#).

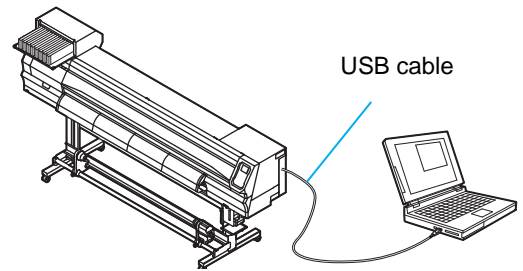

2. Turn on the printer.

- For details, refer to [Chapter 2 “Turning the Power ON” of the printer "Operation Manual"](#).

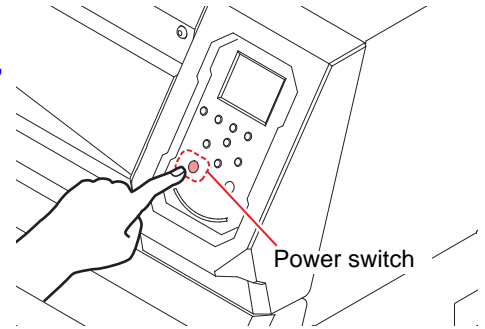

3. Before setting a media, check the height of print head.

- For details, refer to [Chapter 2 “Adjusting the Head Height” of the printer "Operation Manual"](#).
- Adjust the Height-adjusting lever depending on the media to be used.

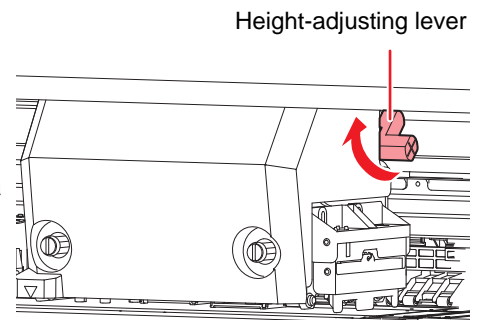

4. Set the media.

- This machine can use roll media and leaf media.
- For details, refer to [Chapter 2 “Set Media” of the printer "Operation Manual"](#).

5. Perform a test printing.

- Check if discharging defect such as nozzle clogging exists or not.
- For details, refer to [Chapter 2 “Test Printing” of the printer "Operation Manual"](#).

6. Perform a media correction.

- Correct the feeding rate of media.
- For details, refer to [Chapter 2 “Setting of Media Correction” of the printer "Operation Manual"](#).

7. Perform a drop position correction.

- Correct the ink drop position.
- For details, refer to [Chapter 2 “If the Positions of Dots Shift...” of the printer "Operation Manual"](#).

Prepare the Mimaki Driver.

1. Check if the Mimaki Driver is installed.



- For the installation, refer to "[Installation Guide](#)" of the Mimaki Driver.
 - The Mimaki driver installation guide can be found in the Mimaki driver installer.
 - About the name of the installer
For the included Driver software CD: mkcdmenu.exe
When downloaded from our website: mkdriver_v***.exe
("****" is the version number)
-

Prepare the RasterLink.

Check that the RasterLink is prepared.

1. Check the installation status of RasterLink.

- If it is installed, the icon of the RasterLink displayed on the PC desktop.
 - For the installation, refer to "[Installation Guide](#)" of the RasterLink.
-

2. Check the connection with the printer.

- Make sure the printer is turned on.
 - Check that the printer is connected to the PC on which RasterLink is installed.
-

3. Double-click the icon to start the RasterLink.

- [Printer Management] is displayed.
-

4. Register the printer.

- If the printer has already been registered, this operation can be skipped. Proceed to "[Perform printing.](#)"

(1) Click [Add] in the [Printer Management] window.

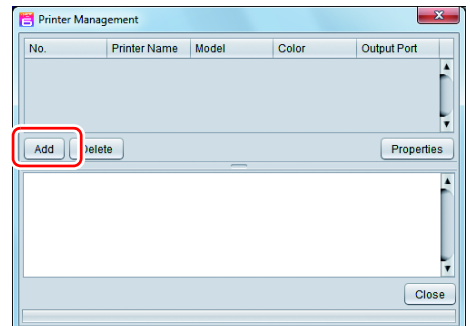

(2) Set the printer information.

(The setup procedure described below assumes that JV150 is connected. Set the printer information in the following order:)

- Model : JV150
- Color : Select depending on the device.
- Output Port : USB2.0
- Available Printers : Select JV150 *****
- Printer Name : Enter the JV150



- The Hot folder of the name entered here is automatically created.
- For an ink set, the information retrieved from the printer is displayed.

(3) Click [OK].

- The confirmation screen is displayed. Clicking [OK] starts the registration of the printer.

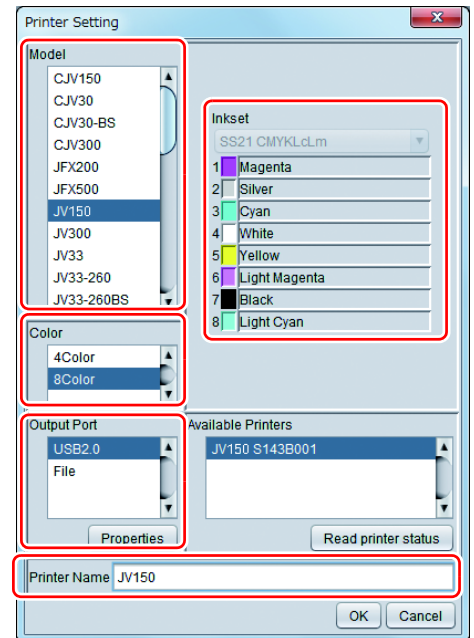

Perform printing.

Here, an example using the image "sample.eps" is explained.

Important!

- Check [P. 3 to P. 5](#) "[Preparation before use.](#)" without fail before creating a seal/a sticker.

1. Double-click the icon of the RasterLink to start the RasterLink.

2. Select [File] - [Open] from the menu.

- The [Select file name to print] dialog is displayed.

About sample images

- Prepare any image data, or use the sample images on the instruction manual CD.
 - (1) Set the CD of the printer "Operation Manual" into the disk drive.
 - (2) Double-click on the "\English\PrintGuide and SampleData" folder.
 - Sample data is displayed.

3. Select the file to be printed, and click [Open].

- If more than one printer is registered, select "JV150" from [Printer Name].
- For details on the favorites setting, refer to "[Reference Guide](#)" of the RasterLink.
- The file is loaded. The loaded file is displayed on the [JV150] tab in the main window.

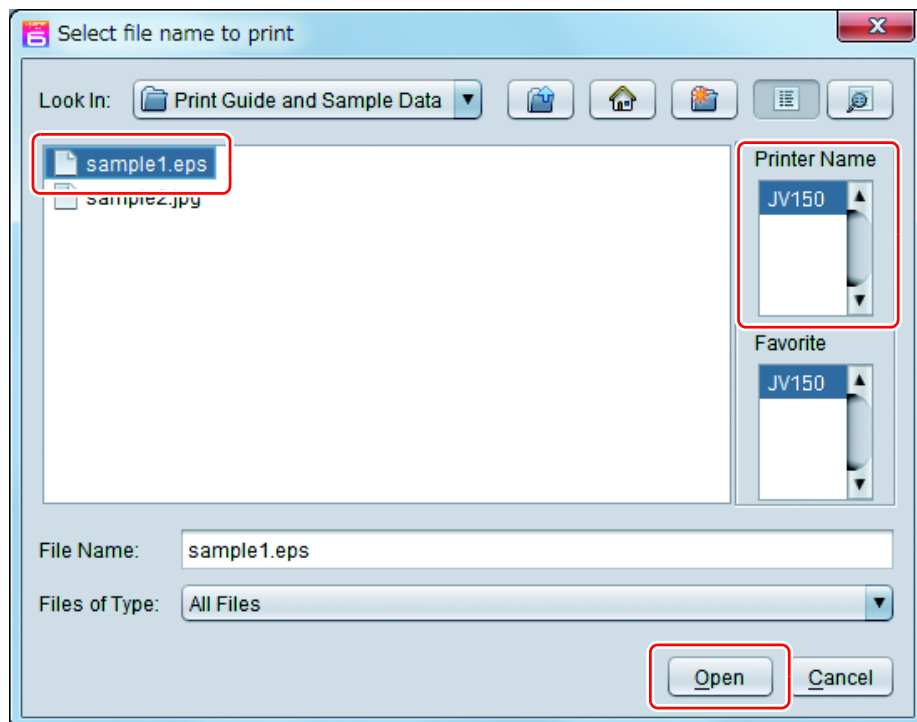

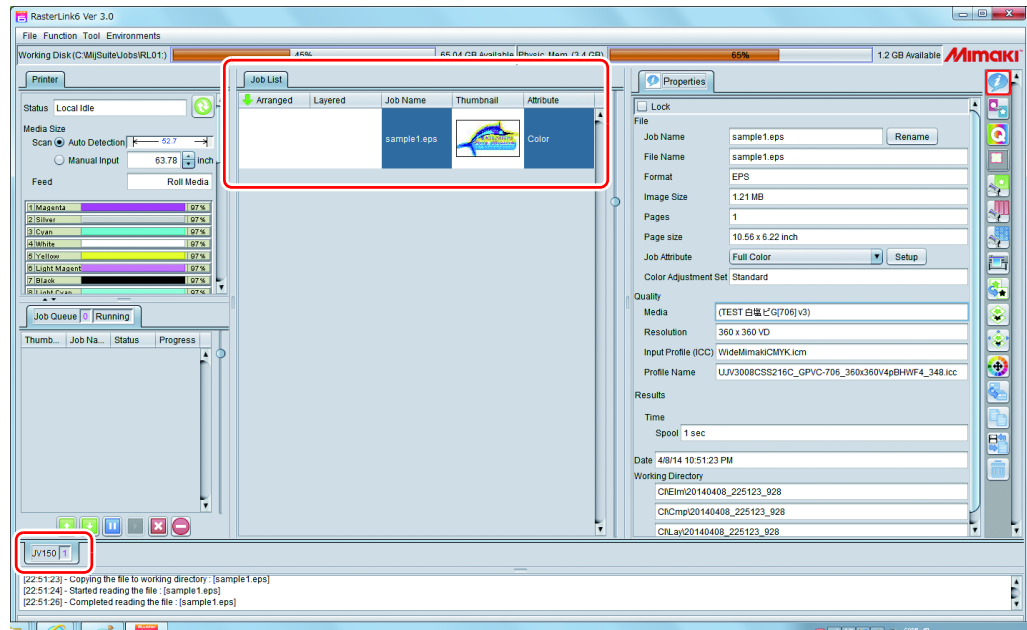

4. Select the file loaded into the [JV150] tab.



5. To check or edit the settings, from [Function icons] displayed in the right side of the window, select the icons shown below.

- For details about each function icon, refer to ["Reference Guide" of the RasterLink.](#)

(1) To specify the enlargement, reduction, or copy setting, select  (General Print).

(2) To select a profile that matches the medium or ink set installed in JV150, select  (Quality).

6. Select (Execution) from the [Function icons] displayed in the right side of the window.

- (1) Select [RIP & Print] or [Immediate Print].
- (2) Click [Start].



- If you have replaced a medium in JV150 series, perform the following steps to acquire the width of the medium from the printer.

1. In the media window, select the [JV150] tab.

2. In the [Printer] section, click  (Display Latest status).

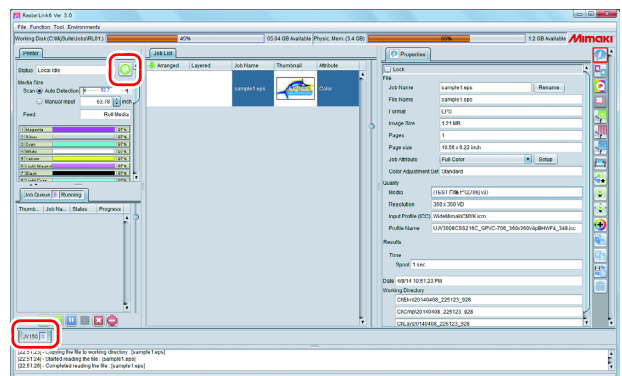

Download the profile suitable for the using condition.

Here, the download method of the profile suitable for the ink set to use is explained.
Read this by replacing the printer/ the profile with the one you use.

1. Start the Profile Update.

- (1) Select [RasterLink] - ([Update] -) [Profile Update] from the Start menu.
- (2) Click [Next].

2. Specify your printer and ink, and click [Next].

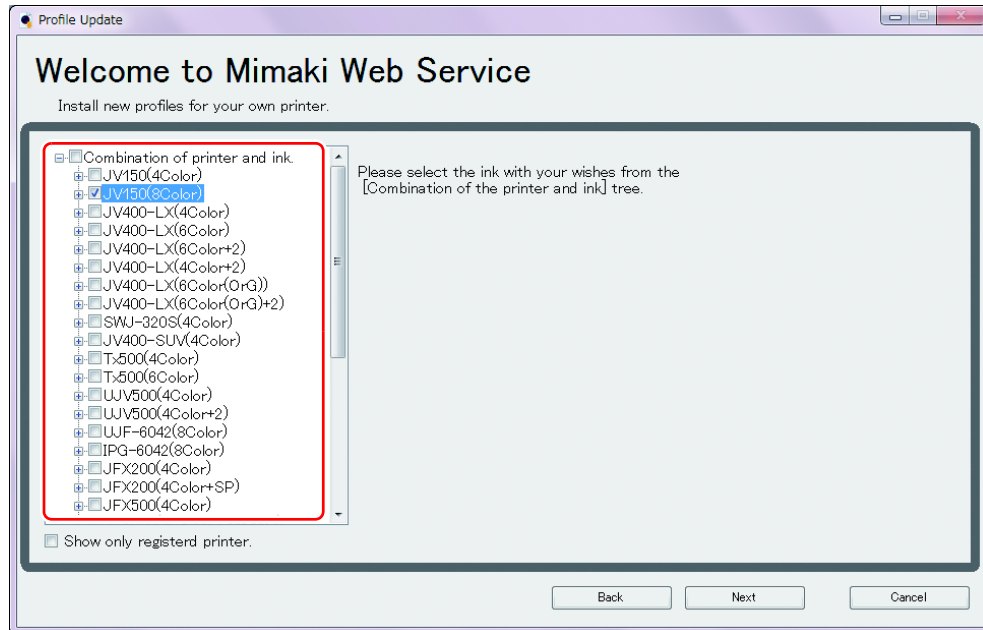

3. Specify the search option and click [Next].

- Checks if there is a profile.

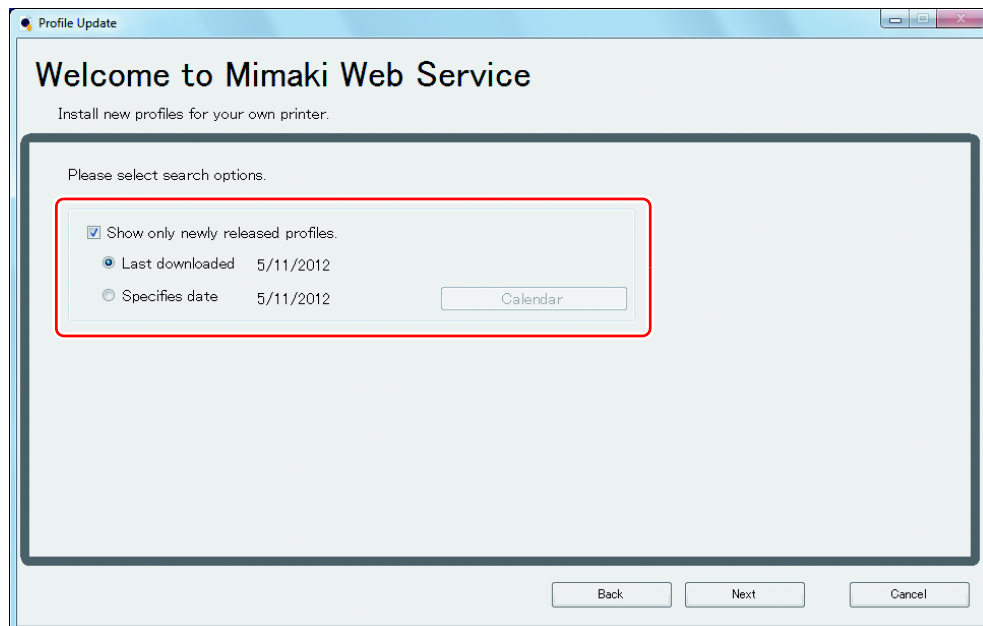

4. Download the profile.

- If there are profiles that meet the settings, the list appears.
(1) Select the profile to install, and click [Next].

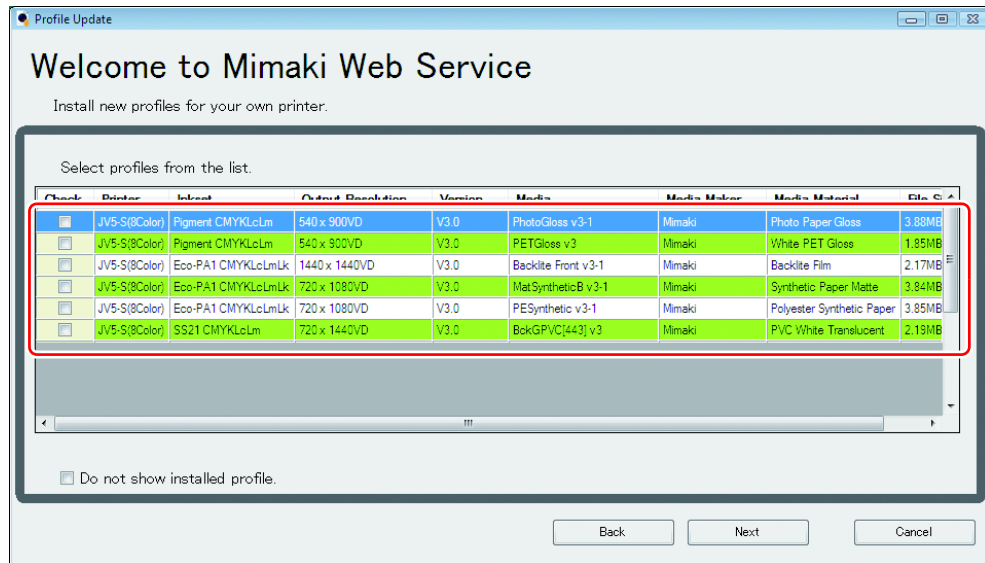

- (2) Click [Finish].



- The profile is installed when RasterLink is started next. Refer to **“Installation Guide” of the RasterLink** for details.
- You can also download the profile from our website. (<https://mimaki.com/>)

Typical questions.

The answers to the questions/ the troubles frequently asked by the customer are provided.

About errors.

● **“Replace a Wiper” appears on the display.**

Time for replacement of the wiper has come.

Replace the wiper by following the procedures in [Chapter 4 “Replacing the wiper” of the printer "Operation Manual"](#).

● **“Waste ink full” appears on the display.**

The waste ink tank will soon be full. Replace the waste ink tank by following the procedures in [Chapter4 “If a Waste Ink Tank Confirmation Message Appears” of the printer "Operation Manual"](#).

Supplied items.

Purchase them in a distributor in your district or our office.

For a list of supplies, refer to ["Supplies" of the printer "Requests for Care and Maintenance"](#).

