

Inkjet printer JFX200-2513

Requests for Daily Care and Maintenance

This machine is a precision machine equipped with extremely fine mechanisms. Especially, the nozzle surface of the heads from which the ink is discharged is affected even by a slightest attachment of dust or paper powder and the proper printing results could not be obtained. With a view to using this machine in a better condition, we would like to recommend performing the following care and maintenance on daily basis.

1. When to care

When to care	What to care	Reference Page
Once a day (at the end of the daily work)	Surroundings of the heads	P.2
	Capping station	P.3
	Wiper	P.4
Twice a week (on Monday and Friday)	Washing the Head Nozzle (When Using the PR-200 ink Ver.2)	P.5
Once a week (at the end of the work on weekend)	Exterior	P.7
	Waste ink tank	P.7
	Around station	P.8
Once a week or two weeks	Replacing the carriage filter	P.9
	Replace the Cotton pad(MBIS)	P.10
Once a month	Refill and check the cooling water	P.10
	Washing the Head Nozzle (When Using the PR-200 ink Ver.3)	P.5
Once every three months	Replacing the wiper	P.10



■ Tools required for maintenance

- Cleaning stick (SPC-0527)
- F-200/LF-200 maintenance liquid (SPC-0568)
- Maintenance liquid (C-ML013-Z-B2-1-KW) *When using the PR-200 ink
- Gloves
- Soft fabric



■ UV curing ink (UV ink) is used in this machine.

- Make sure to wear the attached **safety glasses and gloves.**

2. Daily care



- When possible, use the cleaning stick (SPC-0527) for cleaning around the head/ capping station/ wiper. Using the other cotton bud may attach lint, then it may damage the machine.
- Be sure to perform maintenance for the ink cap and the wiper of capping station every day. If you leave it dirty, dirt may adhere to the nozzle surface, or, dust and dry ink may be rubbed against the nozzle. It may cause discharge defect.
- Clean the bottom of carriage every day so that it will not get dirt from inks or dusts. If you leave it dirty, dust and dry ink may be rubbed against the nozzle at wiping operation when performing head cleaning.
- When you clean the carriage bottom surface, fully be careful not to rub the nozzle surface.

(1) Surroundings of the heads ("Cleaning the Head and the Area around It" Chapter 4 of the Operation Manual)

Important!

- The heads and their surroundings are the parts most liable to be tainted in this machine and if tainted, it could cause adverse effects to the functions of the machine and the results of the printings. Moreover, as the head itself uses very fine mechanisms, sufficient precautions are required for the care and maintenances.

1 After removing the cover of the left side of the flushing, move the carriage to the left edge of the machine.

- Refer to the Step 1 to 5 of Chapter 4 "Cleaning the Head and the Area around It" of the user's manual to perform the operation.

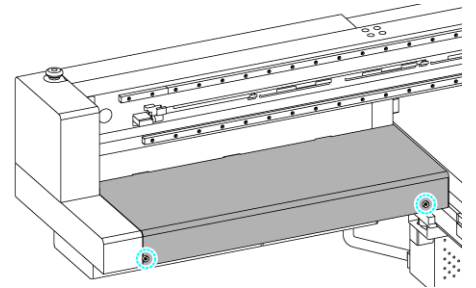

2 Clean the head and the surrounding area.

- Gelled ink and dust could stick under the slider and the surroundings of the head.
- Scrape them off with clean stick etc. In this case, never rub the nozzle portion of the head.

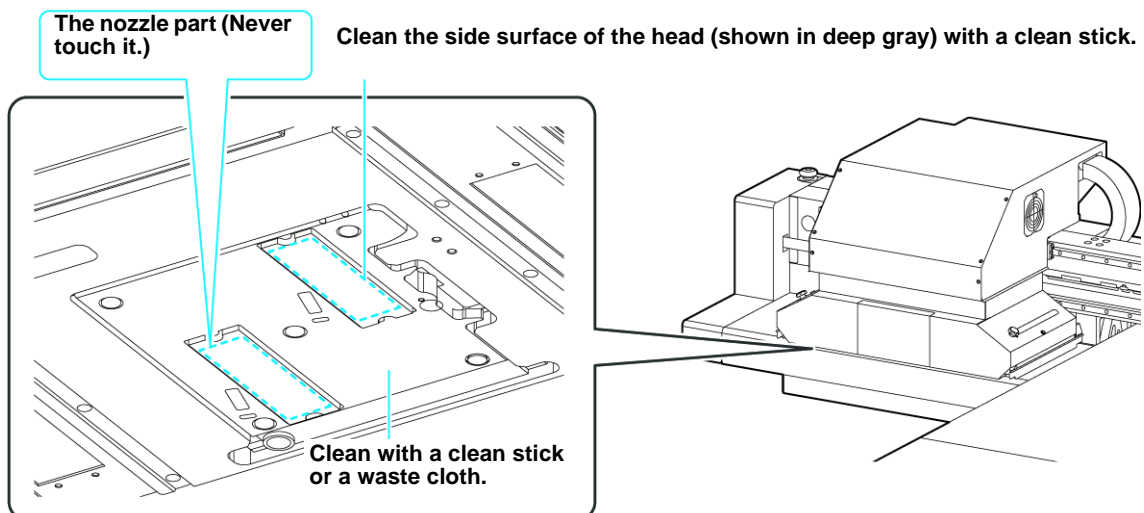

(2) Capping Station ("Cleaning the Wiper and Cap" Chapter 4 of the Operation Manual)

The surrounding area of the cap is also liable to be stained by the dust and ink. It is recommended to clean the head frequently using the cleaning liquid for maintenance suitable for the ink used to avoid the stains on the head.

- Cleaning liquid 03 maintenance kit (ML003-Z-K1)

1 Move the carriage.

- Refer to the Step 1 to 4 of Chapter 4 "Cleaning the Wiper and Cap" of the user's manual to perform the operation.

2 Clean the cap.

- Dip the clean stick into the cleaning liquid for maintenance and wipe off the cap. Wipe off so that cleaning solution for maintenance will not remain.

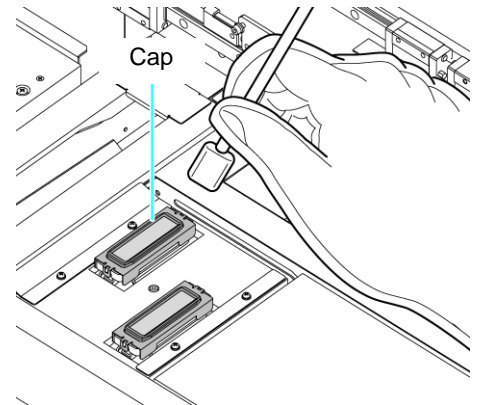

Important!

- Clean the cap rubber and cap rubber cover until it looks as shown in the photo on the right.
- Make sure that the cap rubber and mesh inside the cap have not come off after cleaning.

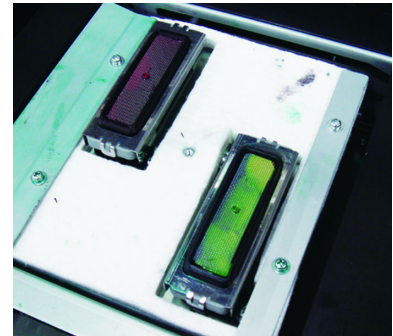

(3) Wiper ("Cleaning the Wiper and Cap" Chapter 4 of the Operation Manual)

On the wiper, the ink, dust and paper powder are liable to accumulate. Check the state of the wiper and if it is stained, clean it.

1 Move the carriage.

- Refer to the Step 1 to 4 of Chapter 4 "Cleaning the Wiper and Cap" of the user's manual to perform the operation.

2 Clean the wiper.

- Remove the wiper by holding the protrusions at its both ends.
- Wipe off the ink sticking to the wiper and bracket with a clean stick dipped in cleaning solution for maintenance. Wipe off so that cleaning solution for maintenance will not remain.

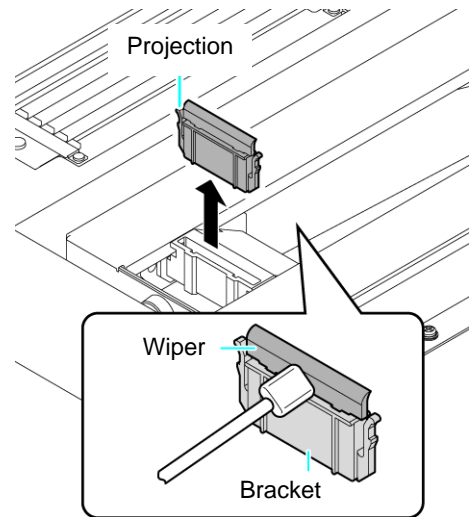

Important!

- Clean the wiper and bracket until it looks as shown in the photo on the right.
- After cleaning, make sure that the bracket and wiper are aligned horizontally.

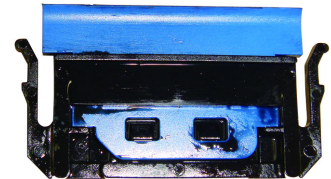

Further, in the cases as explained below, replace the wiper with the new one (SPA-0193) in accordance with "Replacing the wiper" on Chapter 4 of the Operation Manual.





- When the wiper is deformed
- When the stuck ink can not be wiped off
- When the warning for wiper replacement is indicated

3. Periodically care (Twice a week / Only models equipped with PR-200)

On models equipped with the PR-200, ink may clog the nozzle.

Please check the version on the label of the PR-200 ink cartridge, pack, or bottle, and clean the nozzle.

Please clean the nozzle twice a week for Ver.2 and once a month for Ver.3.

Label Ver. notation position	
220ml Cartridge	250ml Bottle
 <p>The image shows the label for a 220ml cartridge. A red box highlights the 'Ver. 2' notation on the label. The label includes the text 'Mimaki IJ Primer PR-200 UV', 'PR200-Z-22', and '220ml'. It also features a barcode and the lot number '12345678'.</p>	 <p>The image shows the label for a 250ml bottle. A red box highlights the 'Ver. 2' notation on the label. The label includes the text 'Mimaki IJ Primer PR-200 UV', 'PR200-Z-B2', and '250ml'. It also features a barcode and the lot number '12345678'.</p>
600ml Pack	1L Bottle
 <p>The image shows the label for a 600ml pack. A red box highlights the 'Ver. 2' notation on the label. The label includes the text 'Mimaki IJ Primer PR-200 UV', 'PR200-Z-60', and '600ml'. It also features a barcode and the lot number '12345678'.</p>	 <p>The image shows the label for a 1L bottle. A red box highlights the 'Ver. 2' notation on the label. The label includes the text 'Mimaki IJ Primer PR-200 UV', 'PR200-Z-BA', and '1000ml'. It also features a barcode and the lot number '12111501'.</p>

(1) Nozzle (“Nozzle Wash (When PR-200 ink using)” Chapter 4 of the Operation Manual)

1 Move the carriage.

NOZZLE WASH [ENT]

2 Clean the wiper and the bracket.

- Remove the wiper by holding the protrusions at its both ends.
- Wipe off the ink sticking to the wiper and bracket with a clean stick soaked in the F-200/LF-200 maintenance liquid.

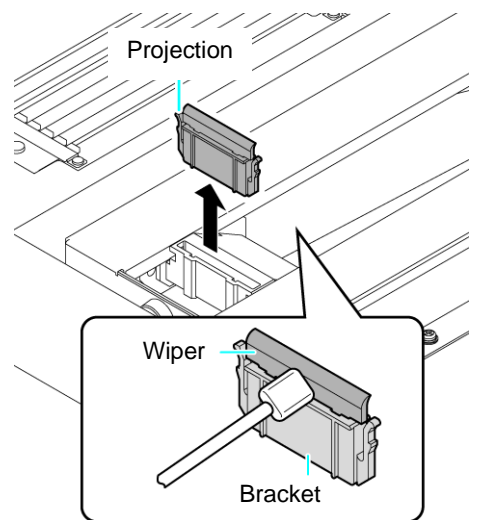

3 Clean the cap.

- Wipe off any ink on the cap rubber and the cap rubber cover using a clean stick soaked in the F-200/LF-200 maintenance liquid.

Important!

When cleaning the wiper, bracket, cap rubber, and cap rubber cover, be sure to use the F-200/LF-200 maintenance liquid, and do not use the PR-200 maintenance liquid (C-ML013-Z-B2-1-KW).

- Wipe it off properly so that there is no residual F-200/LF-200 maintenance liquid.

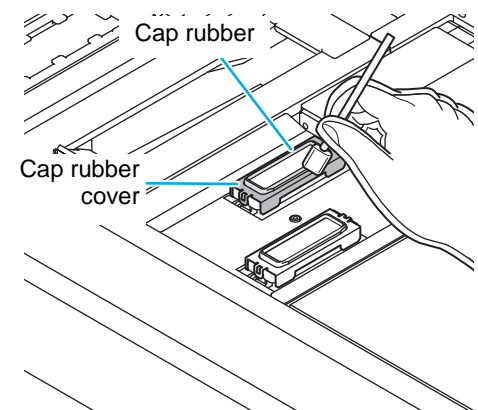

4 Take the PR-200 maintenance liquid (C-ML013-Z-B2-1-KW) and fill only the cap of the head equipped with PR-200 with it until it is full.

- Fill the cap with the cleaning solution just before the solution overflows from the cap.

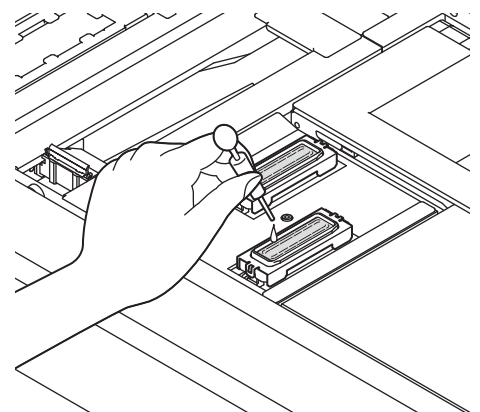

5 Press to enter the leaving time. (Supported from firmware version 2.9 onward)

- Recommended time is 1 minute.

6 Press the ENTER key to start nozzle cleaning.

- The screen on the right is displayed during cleaning.
- After cleaning, return to the Step 1 screen.

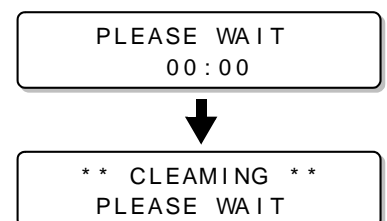

7 Execute head cleaning (HARD) once for the head equipped with PR-200.

- Refer to the Step 10 of Chapter 4 “Washing of Head nozzle (When Using the PR-200 maintenance liquid)” of the user’s manual to perform the operation.

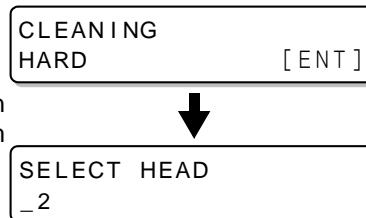

8 Check the nozzle status by performing a test print.

- When the nozzle clogging occurs, execute nozzle cleaning (HARD) again then check the nozzle status.

4. Periodically care (Once a week)

Users are advised to perform the maintenance works described below once a week so that the printer will keep its high performance and accuracy over an extended period of its life.

(1) Exterior (“Cleaning the Exterior Surfaces” Chapter 4, Operation Manual)

Depending on the using environment, the dusts or sand powder could stick to the exterior of the main unit. To avoid the entry of the dusts into the moving part of the head, wipe them off with soft cloth dipped into water and squeezed tightly.

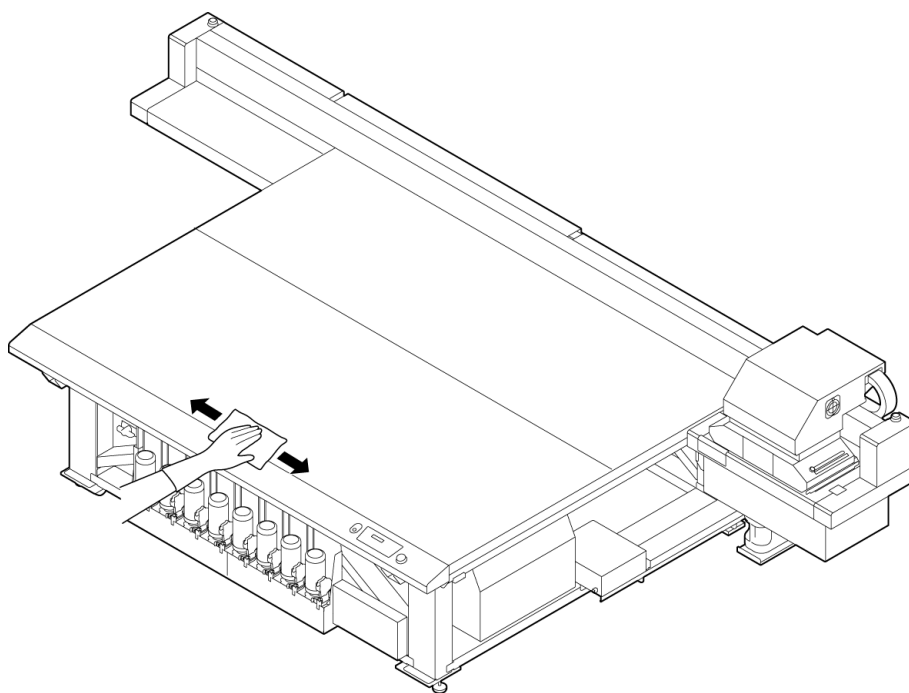

(2) Waste ink tank (“Replace the waste ink tank with another” Chapter 4 of the Operation Manual)

Check whether the waste ink tank is full or not. Take care so that the waste ink never overflows the tank.

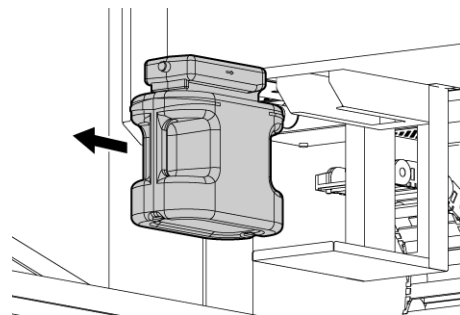

(3) Cleaning the around station (“Cleaning the around station” Chapter 4 of the Operation Manual)

It is recommended that the wiper and cap be cleaned frequently in order to maintain the high image quality of the machine and keep the machine itself in good working order.

1 Move the carriage.

- Refer to the Step 1 to 4 of Chapter 4 “Cleaning the around station” of the user’s manual to perform the operation.

2 Using a waste cloth etc., wipe off ink adhering to the around station.

- Clean the grey-colored area in the figure on the right.
- When you cannot wipe off ink because it is firmly fixed, scrape it with a spatula etc.

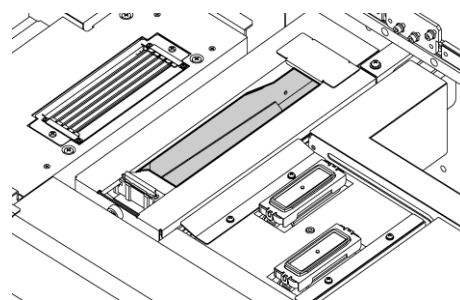

3 Wipe off ink adhering to the flushing unit and/or shutter portions.

- Soak the clean stick in the maintenance liquid, and then remove the ink that has adhered . Wipe off so that cleaning solution for maintenance will not remain.

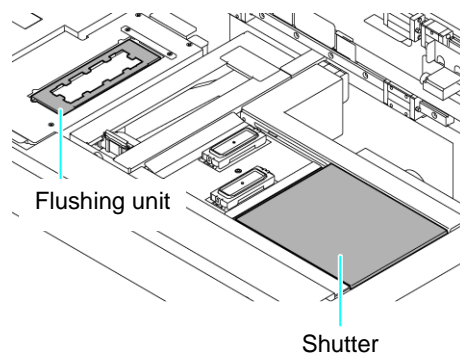

4 Press the **ENTER** key after the cleaning.

5. Periodically care (once a week or two weeks)

(1) Replacing the carriage filter

Replace it once in a week or two weeks.

1 Move the carriage.

- Refer to the Step 1 to 4 of Chapter 4 "Cleaning the Wiper and Cap" of the user's manual to perform the operation.

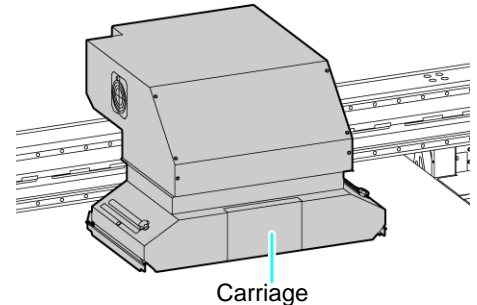

2 Remove the carriage filter cover (at the right and left of the carriage and the rear side).

- Remove the carriage filter cover of right and left of the carriage.
- Pinch the claw attached to the upper part of the carriage filter cover and pull it to the front.

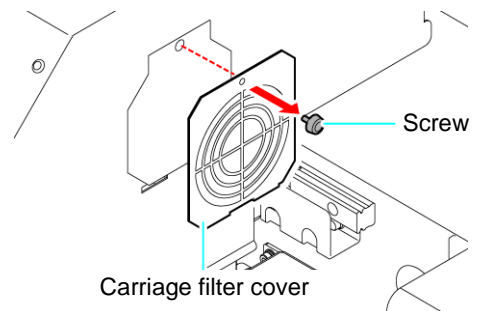

3 Remove the used carriage filter cover.

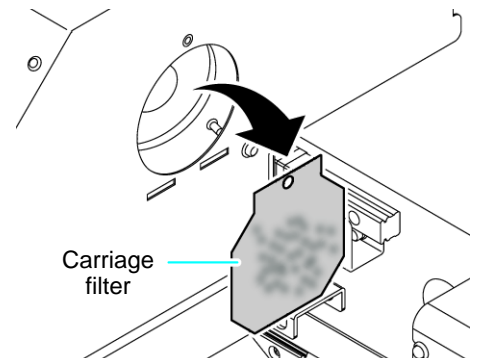

4 Mount a new carriage filter (SPA-0189).

- Insert the holes of right and left of the carriage filter into the convex part of the carriage.

Important!

- The carriage filter is located at right and left and rear side of the carriage.
Replace all filters at the same time.

5 Return the carriage filter cover to the original status.

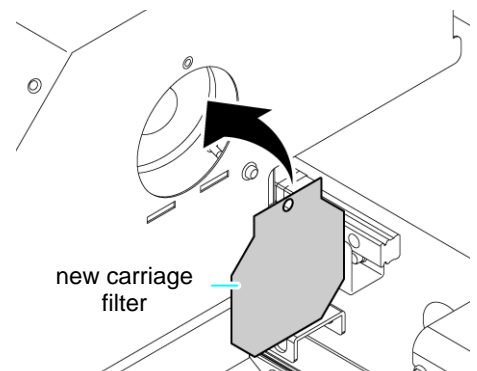

6 When replacement has been completed, press the **ENTER** key.

(2) Replace the Cotton pad(MBIS) (“MBIS Maintenance” Chapter 4 of the Operation Manual)

There is a cotton pad attached to the cap wiper section on the rear of the tank that is used to wipe off any ink adhering to the underside of the cap when replacing ink bottles of the MBIS. Periodically replace the cotton pad. (Recommended replacement period: Once every two weeks or once every fifth time bottles are replaced.)

6. Periodically care (once a month)

(1) Refill and check the cooling water (“Refill cooling water” Chapter 4 of the Operation Manual)

It is recommended that check the amount of cooling water about once a month to keep the machine itself in good working order.

When cooling water is a little, refill the cooling water.

7. Periodically care (Once every three months)

(1) Replacing the wiper (“Replacing the wiper” Chapter 4 of the Operation Manual)

The wiper is consumable. When the display indicates that it is necessary to replace the wiper, immediately replace the wiper with a new one.

Also, wipe ink sticking to the lower surface of the slider off.

```
<LOCAL>  
Replace a WIPER [MNT]
```

8. Storage of media

Media should be stored in the little dust area, and not in direct sunlight. Avoid storing the media in the area with high temperature and high humidity.

9. Storage of ink bottle

Be careful of the followings to store.

- Store the ink bottle in no direct sunlight, and no high humidity.
- As it's a delicate product, do not drop it.
- Ink IC should not be contaminated and discharged static electricity.
- Be sure to store the ink bottle and the ink IC together.



Ink bottle and Ink IC

10. The examples of defective printing

These following examples indicate improper head (nozzle) firing by dust, which effect printing. Confirm the nozzle condition periodically before or during outputting not to use in such as this condition. The nozzle condition can be confirmed with [test printing] in this plotter. (Operation manual Chapter 2 "Test Printing")

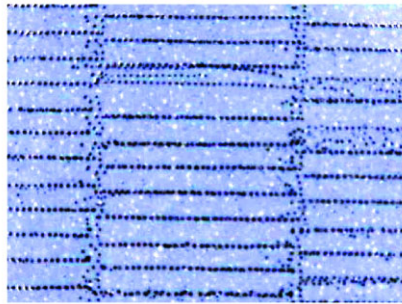

Deflection

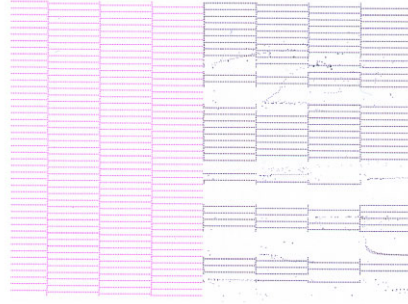

Nozzle out



Ink drooping



Satellite

11. Recovery method of defective nozzle discharge

When this printer has not been used for an extended period of time, or depending on the environmental temperature, the discharge at the nozzles could become unstable. In such a case, the following methods may be taken to recover the status of the nozzles.

1. Daily maintenance and care

- Perform the cleaning of the parts described in this document.

2. Performing Head Cleaning (normal). Refer to Chapter 2 of Operation Manual.

- After having performed the care and maintenance stated in step 1, perform the cleaning of the heads in accordance with the procedures stated in Operation Manual.

Perform test printing and check
(Chapter 2 of Operation Manual)

In the event nozzle missing etc. have not been improved

3. Performing Head Cleaning (hard). Refer to Chapter 2 of Operation Manual.

- If the nozzle missing does not disappear even after repeating the head cleaning (normal) several times, reset the cleaning mode to "hard" and perform the cleaning again.

Perform test printing and check
(Chapter 2 of Operation Manual)

In the event nozzle missing etc. have not been improved

4. Set the nozzle recovery function. Refer to Chapter 4 of Operation Manual.

- Set the nozzle recovery function.

Perform test printing and check
(Chapter 2 of Operation Manual)

If the nozzle missing has not been improved even with the above operations, please call us or your sales agent from whom you purchased this printer.

12. Supplies

To order replacement consumable items, contact your local dealer or our service office.

Product Name	Product No.	Product Name	Product No.
F-200/LF-200 maintenance liquid	SPC-0568	PR-200 maintenance liquid	C-ML013-Z-B2-1-KW
Waste ink tank	SPA-0197	Filter element	SPA-0209
Clean stick for the surroundings of the head 50pcs	SPC-0527	Carriage filter	SPA-0189
Ink filter white	SPA-0196	Wiper kit	SPA-0193

For more information on other consumable items, refer to our website.

<https://mimaki.com/supply/inkjet.html>

13. Safety Precautions

CAUTION



UV curing ink (UV ink) is used in this machine. Make sure to wear the attached **safety glasses and gloves**.



The ink, if mixed with water or alcohol, generates condensed substances. Pay attention not to deposit water or alcohol to the nozzle surface, surrounding area of the heads, caps and wipers.



To secure the stability of the ink discharge, when the printer is not used (output) for an extended period of time, it could become necessary to discharge periodically a small amount of ink (flushing), depending on the kinds of the ink.

When not using for an extended period of time, execute the [CUSTODY WASH] function of this equipment, ("When the Machine Is Not Used for a Long Time (CUSTODY WASH)" Chapter 5 of Operation Manual) and put off the power switch on the front, only. Leave the main power switch at the side of the equipment on and keep the cable socket inserted into the plug.



Make maintenance after the LED UV has been sufficiently cooled, or burn injury may occur.



Never disassemble this machine. It could cause electrical shock, fire and breakage.



Keep away the moisture from the inside of this machine. If the inside is moistened, it could cause electrical shock, fire and breakage.



Perform the maintenance and care after switching off the power and taking off the power cable. Otherwise, it could cause unexpected accidents.



Avoid using benzene, thinner, and chemicals containing abrasive compounds. The surface of the cover could be degenerated or deformed.



Do not supply lubricant oil etc. to the inside this machine. It could cause the breakdown of this machine.



UV curing ink (UV ink) generates agglomerates when mixed with water or alcohol. Be careful not to allow water or alcohol to adhere to the area around the print head, cap, suction nozzle, etc.

14. Installation environment

- Use this printer as much as possible in a dust-free environment. Fans and air-blowers could cause the dustspewing.
- The using environment of this printer is from 15 to 30°C (59°F to 86°F) in temperature and from 35 to 65 % in relative humidity. Avoid the use of this printer at a temperature and humidity higher or lower than the indicated ranges.

15. Notes for working environment

Performing frequency of the print setting or maintenance is greatly influenced by the printing environment or the condition of the media used. Use this machine with a full understanding of the followings.

Working environment	Consideration
In the gritty and dusty place	<ul style="list-style-type: none"> ▪ To keep the nozzle face clean, set to wipe periodically every time it prints about 1500 mm. (Operation Manual Chapter 4 "Setting nozzle face cleaning time") ▪ Change the setting of periodic wiping depending on the amount of dust.
When the head gap is set wide because fibers stick out of media	<ul style="list-style-type: none"> ▪ UV light can expose the nozzle when there is a lot of scattered mist. Raise the refreshing level for drawing (Operation Manual Chapter 3 "Other useful settings"), and set the periodic wiping (Operation Manual Chapter 4 "Setting nozzle face cleaning time"). ▪ Increase performing frequency of every maintenance.
When the media that reflects UV light well is used such as glasses or glazed metal	
When there is an infrequentlyused ink (print head)	<ul style="list-style-type: none"> ▪ An infrequently-used print head can be unstable to discharge ink comparing with the other print heads. Raise the refreshing level for drawing (Operation Manual Chapter 3 "Other useful ettings") to raise the usage rate of the head.
When printing on the media on which static can be charged	<ul style="list-style-type: none"> ▪ Put humidifiers on to avoid charge. Static may collect mist or dust around the printing area or the head. To print continuously for a long time, set the periodic wiping. (Operation Manual Chapter 4 "Setting nozzle face cleaning time")
When printing in a dry place (such as in winter)	
When printing on a markedly uneven media (or object)	<ul style="list-style-type: none"> ▪ To keep the head gap the same, set extra media outside the suction area where a printing media is set. Leaving the head that has been degraded by reflected light may cause failure that needs replacing of the head.

16. Maintenance when needed

Important!

A proper maintenance schedule is determined by the operator who observes throughout a period of use of the printer.

- Some media need maintenance every time of printing.
- The maintenance schedule differs depending on the image to be printed. For example, when the image is almost filled, perform maintenance frequently.

(1) Cleaning of the LED UV unit

Remove ink or dust attached to the LED UV periodically.

Important!

- Clean the LED UV with care in order not to scratch an irradiation part on the bottom of the unit. If there is a certain amount of dirt or a light shielding object on the irradiation part, ink may not cure well and it may cause banding.

(2) Removal of ink attached to the table

If necessary, remove ink attached to the table with an alcohol-impregnated cloth. Be careful not to scratch the table face when removing cured ink.

Important!

Caution when using solvent

- Leaving the table after attachment of ink may make the ink removal hard with alcohol only. When using a special solvent, contact our office before use. It may cause a failure of the machine.

(3) Removal of the vacuum hole clogging on the table

The vacuum holes on the table can be clogged with ink. Remove the ink in the vacuum holes when needed. Be careful not to leave a part of cured ink on the table.

(4) Cleaning of the bottom of the carriage

Remove ink attached to the bottom of the carriage.

(5) Cleaning of the print head nozzle face with a cleaning swab

When an image is printed on a special media, or when this machine is not used for a long time, the nozzle may not be cleaned only with a normal cleaning.

Soak a specified cleaning swab into the maintenance liquid, and wipe out things adhered on the nozzle face. Perform this work under the direction of our service engineer.

(6) Maintenance of Optional Ionizer

For the maintenance, refer to Instruction Manual of Ionizer.



You can also download the latest manual from our website.

© 2014 MIMAKI ENGINEERING CO., LTD.

D202565-14-26102023

KM
FW :2.90