

**COLOR INKJET PRINTER**

# ***Tx500-1800B***

**OPERATION MANUAL**

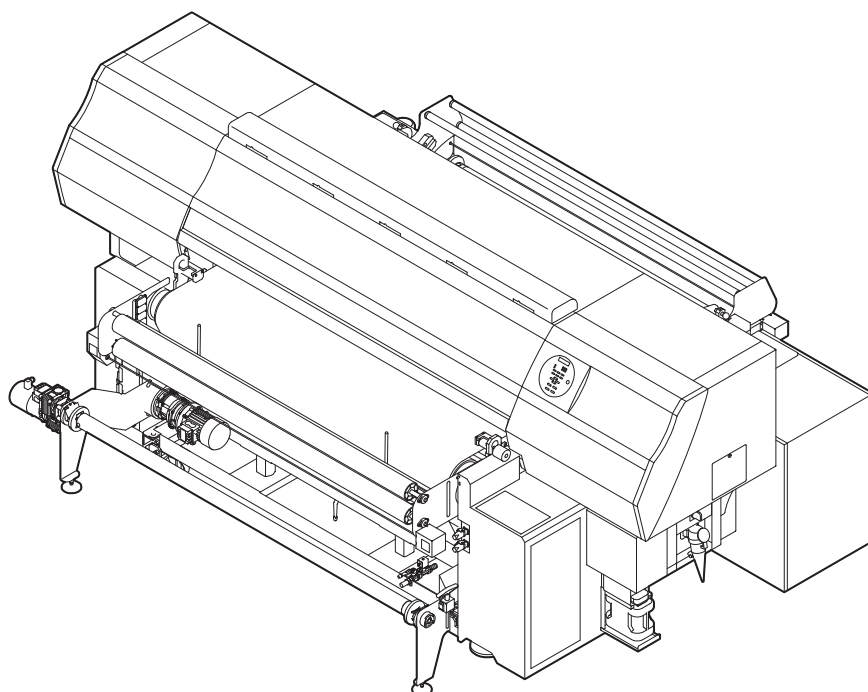

You can also download the latest manual from our website.

**MIMAKI ENGINEERING CO., LTD.**

URL: <http://mimaki.com/>

D202495-16

Original instructions

# TABLE OF CONTENTS

CAUTION .....	v
DISCLAIMER OF WARRANTY .....	v
Requests .....	v
FCC Statement (USA) .....	v
Interference to televisions and radios .....	v
Foreword .....	vi
On This Operation manual .....	vi
Safety Precautions .....	vii
Symbols .....	vii
Safety interlock .....	xi
Emergency switch .....	xii
EC DECLARATION OF CONFORMITY .....	xv

## Chapter 1 Before Use

About installing this machine .....	1-2
Where to Install This Machine .....	1-2
Working Environmental Temperature .....	1-2
About fixing machine .....	1-3
Moving This Machine .....	1-3
Names of Parts and Functions .....	1-4
Front Side of the Machine .....	1-4
Rear Side and Right Side of the Machine .....	1-5
Operation Panel .....	1-6
Operation Touch Panel .....	1-7
Operation Panel (Front surface of media feeding part) ....	1-8
Operation Panel (Rear surface of media feeding part) ....	1-9
Power of media feeding part .....	1-9
Carriage .....	1-10
Indicator .....	1-10
Capping station .....	1-10
Setting up .....	1-11
Setup of media feeding part .....	1-11
Connecting Cables .....	1-15
Connecting USB2.0 Interface Cable .....	1-15
Connecting Power Supply Cable .....	1-16
Setting ink bottles .....	1-17
For ink .....	1-22
Ink type .....	1-22
Caution in handling of ink bottles .....	1-22
Media .....	1-23
Usable Sizes of Media .....	1-23
Limited media .....	1-23

## Chapter 2 Basic Operations

Workflow .....	2-2
Turning the Power ON/OFF .....	2-3
Turning the Power ON .....	2-3
Turning the Power OFF .....	2-5
Automatic function .....	2-6

Assistant functions .....	2-7
Switching ON/OFF of Centering function .....	2-7
Switching ON/OFF of Media detecting function .....	2-8
Switching ON/OFF of Belt washing function .....	2-9
Switching ON/OFF of Air blade .....	2-9
Switching ON/OFF of Belt heater .....	2-10
Setting a Media .....	2-11
Maximum Print Area .....	2-11
Notes for Setting a Media .....	2-11
Outline of media setting .....	2-12
About media route .....	2-12
Attach the fabric winding roller .....	2-13
Feed the media .....	2-15
Take up the media .....	2-21
Setting the Head Gap .....	2-23
Detecting the Media .....	2-24
Changing the printing origin .....	2-25
When Using the Optional Heater MTA-190 .....	2-26
Notes for when using the heater .....	2-26
Turning the Power ON .....	2-27
Turning the Power OFF .....	2-27
Adjust the angle of the optional heater MTA-190 .....	2-28
Adjust the temperature of the heater .....	2-29
Test Feeding .....	2-30
Test Printing .....	2-31
Test Printing .....	2-32
Head Cleaning .....	2-33
About head cleaning .....	2-33
Perform head cleaning depending on the test printing result .....	2-33
Set the media feeding .....	2-34
Setting Feed Correction .....	2-34
Correct the ink drop position for bidirectional printing .....	2-36
Printing Data .....	2-38
Starting a Printing Operation .....	2-38
Stopping a printing operation halfway .....	2-39
Deleting Received Data (Data Clear) .....	2-39

## Chapter 3      **Extended Functions**

List of Functions .....	3-2
Setting Logical Seek .....	3-3
Setting Drying Time .....	3-4
Perform setting to reduce stripes between passes .....	3-5
Improving the image quality by changing the media feeding amount .....	3-7
Setting Auto Cleaning .....	3-8
Setting nozzle face cleaning time .....	3-9
Other Settings .....	3-10
Machine Settings .....	3-11
Setting a AUTO Power-off .....	3-13

Setting the Display of Media Residual .....	3-14
Setting Time .....	3-16
Setting Units .....	3-17
Setting a KEY BUZZER .....	3-18
Selecting the head line to use .....	3-19
Setting a LANGUAGE .....	3-20
Setting a MEDIA DETECT .....	3-21
Setting a DRYING FEED .....	3-22
Setting a View Feed .....	3-23
Setting the feed mode of the space of no data to be printed .....	3-24
Set the network .....	3-25
Setting event mail function .....	3-27
Setting the Setting Lock function .....	3-37
Initializing the Settings .....	3-39
Confirming Machine Information .....	3-40
Check the using status of the machine .....	3-40
Check the machine version information .....	3-42
Displaying the Information of this machine .....	3-43

## Chapter 4 Maintenance

Maintenance .....	4-2
Precautions for Maintenance .....	4-2
About Cleaning Solution .....	4-2
Cleaning the Exterior Surfaces .....	4-3
Cleaning the Media Sensor .....	4-3
When not using the machine for a long period of time .....	4-4
When not using this machine for two days (weekends, etc) .....	4-4
When not using this machine for more than three days ...	4-5
When using this machine after not having used it for a long period of time .....	4-5
Maintaining the Capping Station .....	4-6
Cleaning the Wiper and Cap .....	4-6
Cleaning the wiper ink pan .....	4-9
Washing the Ink Discharge Passage (DISWAY WASH) .....	4-11
When the Machine Is Not Used for a Long Time (CUSTODY WASH) .....	4-12
Cleaning the Head and the Area around It .....	4-15
When Nozzle Clogging Cannot Be Solved .....	4-17
Washing of Head nozzle .....	4-17
Alternative nozzles for printing, when nozzles missing can not be improved .....	4-19
Automatic Maintenance Function .....	4-23
Setting the Refreshing Intervals .....	4-23
Setting the Cleaning Intervals .....	4-24
Cleaning Y motor .....	4-25
Replacing consumables .....	4-26
Replacing the wiper .....	4-26
If a Waste Ink Tank Confirmation Message Appears .....	4-27
Cleaning the washing unit .....	4-29

Cleaning of peeling sensor .....	4-30
When power of adhesive weakened .....	4-31
Be sure to check before recoating adhesive .....	4-32
Peel weakened adhesive .....	4-34
Coat new adhesive .....	4-38

## **Chapter 5     Troubleshooting**

Troubleshooting .....	5-2
Power does not turn on .....	5-2
The machine does not start printing .....	5-2
When an error occurs in media .....	5-3
Image quality is poor .....	5-3
Nozzle is clogged .....	5-4
Ink bottle warning appears .....	5-4
If an error related to the sub tank occurs (Error 618 to 61b) .....	5-5
If nozzle missing due to color mixture of ink or aeration ...	5-6
If negative pressure abnormality occurs .....	5-8
If a head failure error is displayed .....	5-10
Warning / Error Messages .....	5-12
Warning messages .....	5-12
Error messages .....	5-15

## **Chapter 6     Appendix**

Specifications .....	6-2
Machine specifications .....	6-2
Ink specifications .....	6-3
Setting orders depending on ink type .....	6-4
Setting orders of ink bottles .....	6-4
Sheet for inquiry .....	6-5
Warning labels .....	6-6
Function Flowchart .....	6-8

## DISCLAIMER OF WARRANTY

THIS LIMITED WARRANTY OF MIMAKI SHALL BE THE SOLE AND EXCLUSIVE WARRANTY AND IS IN LIEU OF ALL OTHER WARRANTIES, EXPRESS OR IMPLIED, INCLUDING, BUT NOT LIMITED TO, ANY IMPLIED WARRANTY OF MERCHANTABILITY OR FITNESS, AND MIMAKI NEITHER ASSUMES NOR AUTHORIZES DEALER TO ASSUME FOR IT ANY OTHER OBLIGATION OR LIABILITY OR MAKE ANY OTHER WARRANTY OR MAKE ANY OTHER WARRANTY IN CONNECTION WITH ANY PRODUCT WITHOUT MIMAKI'S PRIOR WRITTEN CONSENT.

IN NO EVENT SHALL MIMAKI BE LIABLE FOR SPECIAL, INCIDENTAL OR CONSEQUENTIAL DAMAGES OR FOR LOSS OF PROFITS OF DEALER OR CUSTOMERS OF ANY PRODUCT.

## Requests

- This Operation manual has been carefully prepared for your easy understanding. However, please do not hesitate to contact a distributor in your district or our office if you have any inquiry.
- Description contained in this Operation manual are subject to change without notice for improvement.

## FCC Statement (USA)

This equipment has been tested and found to comply with the limits for a Class A digital device, pursuant to Part 15 of the FCC Rules. These limits are designed to provide reasonable protection against harmful interference when the equipment is operated in a commercial environment. This equipment generates, uses and can radiate radio frequency energy and, if not installed and used in accordance with the Operation manual, may cause harmful interference to radio communications.

Operation of this equipment in a residential area is likely to cause harmful interference in which case the user will be required to correct the interference at his own expense.

In the case where MIMAKI-recommended cable is not used for connection of this device, limits provided by FCC rules can be exceeded.

To prevent this, use of MIMAKI-recommended cable is essential for the connection of this printer.

## Interference to televisions and radios

The product described in this manual generates high frequency when operating.

The product can interfere with radios and televisions if set up or commissioned under improper conditions.

The product is not guaranteed against any damage to specific-purpose radio and televisions.

The product's interference with your radio or television will be checked by turning on/off the power button of the product.

In the event that the product is the cause of interference, try to eliminate it by taking one of the following corrective measures or taking some of them in combination.

- Change the orientation of the antenna of the television set or radio to find a position without reception difficulty.
- Separate the television set or radio from this product.
- Plug the power cord of this product into an outlet which is isolated from power circuits connected to the television set or radio.

# Foreword

Congratulations on your purchase of MIMAKI color ink jet printer "Tx500 Series" .  
"Tx500-1800B" is a color inkjet printer that can print with Textile ink realizing high speed and high image quality.

## On This Operation manual













- This Operation manual is describing the operations and maintenance of "Color inkjet printer Tx500-1800B" (called as this machine hereafter)
- Read this Operation manual carefully and understand them thoroughly to use.
- It is also necessary to keep this Operation manual on hand.
- This Operation manual has been carefully prepared for your easy understanding, however, please do not hesitate to contact a distributor in your district or our office if you have any inquiry.
- Descriptions contained in this Operation manual are subject to change without any notice for improvement.
- You can also download the latest manual from our website.

# Safety Precautions

## Symbols

Symbols are used in this Operation Manual for safe operation and for prevention of damage to the machine. The indicated sign is different depending on the content of caution. Symbols and their meanings are given below. Please follow these instructions as you read this manual.

### Examples of symbols

Meaning	
	Failure to observe the instructions given with this symbol can result in death or serious injuries to personnel. Be sure to read it carefully and use it properly.
	Failure to observe the instructions given with this symbol can result in injuries to personnel or damage to property.
	Important notes in use of this machine are given with this symbol. Understand the notes thoroughly to operate the machine properly.
	Useful information is given with this symbol. Refer to the information to operate the machine properly.
	Indicates the reference page for related contents.
	The symbol "  " indicates that the instructions must be observed as strictly as the CAUTION instructions (including DANGER and WARNING instructions). A sign representing a precaution (the sign shown at left warns of hazardous voltage) is shown in the triangle.
	The symbol "  " indicates that it is the forbidden action. If there is a concrete instruction, it is indicated in or around the symbol "  ".
	The symbol "  " indicates that the action is forced to be done or the instruction must be observed. If there is a concrete instruction, it is indicated in the symbol "  ".



## Warning for Use



### WARNING



- Do not use the machine in a poorly ventilated room or a closed room.
- Take care not to damage, break or work upon the power cable. If a heavy material is placed on the power cable, or if it is heated or pulled, the power cable can break, thus resulting in fire or electric shocks.
- Avoid locating the machine in a damp environment. Do not splash water onto the machine. Use in such an environment can give rise to fire, electric shocks or breakdown of the machine.
- Use it with the displayed power supply specifications. The power-supply voltage of this machine shall be three-phase 380 to 420 Vac 20 A and less. (You cannot use this machine in the 100V system.)
- Do not use in a humid area or pour water on the machine; doing so may cause a fire or an electric shock or breakdown of the machine.
- If you leave the machine in an abnormal status such as smoke or odor coming from the machine, it may cause a fire or an electric shock. Turn off the machine immediately, and then turn off the breaker of the distribution board. Check that no more smoke is coming out from the machine, and then contact a distributor or our office for service. Never try to mend the machine yourself as it is dangerous.
- Never disassemble or remodel the main unit of the machine or the ink bottle. Disassembly or remodeling can result in an electric shock or breakdown of the machine.
- Take care not to stick dust, dirt or the like to the heater of belt. It may catch or cause a fire.



#### Hazardous Moving Parts

Keep Fingers and Other Body Parts Away

## Precautions in Use



### CAUTION



Power supply		Handling of the power cable	
<ul style="list-style-type: none"> <li>• Leave the breaker turned ON.</li> <li>• Do not turn off the main power switch on the right side of this machine.</li> </ul>	<ul style="list-style-type: none"> <li>• Use a power cable attached to this unit.</li> <li>• Take care not to damage, break or work on the power cable. If a heavy matter is placed on the power cable, heated or drawn, the power cable can break to cause fire or electric shocks.</li> </ul>		
Heater		Handling of ink	
<ul style="list-style-type: none"> <li>• Do not spill liquid on the belt heater as this may cause failure of the heater or firing.</li> <li>• Do not touch the belt heater with a bare hand while it is hot. It may cause burning.</li> </ul>	<ul style="list-style-type: none"> <li>• If you get ink in your eyes, immediately wash your eyes with a lot of clean water for at least 15 minutes. In doing so, also wash eyes to rinse ink away completely. Then, consult a doctor as soon as possible.</li> <li>• If anyone drinks ink by mistake, keep him or her quiet and see a doctor immediately. Do not allow him or her to swallow the vomit. After that, contact the Poison Control Center.</li> <li>• If you inhale a lot of vapor and feel bad, immediately move to a location of fresh air and then keep yourself warm and quiet. Then, consult a doctor as soon as possible.</li> </ul>		
Note on maintenance			
	<ul style="list-style-type: none"> <li>• When cleaning the External ink supply unit or the heads, make sure to wear the attached gloves.</li> </ul>		

## CAUTIONS and NOTES

 <b>Warning</b>	
<b>Handling of ink bottles</b>	<b>Front cover</b>
<ul style="list-style-type: none"> <li>• Use the Tx500 genuine ink. Remember that the user shall be filled for a repair to correct any damage resulting from the use of ink other than the exclusive type.</li> <li>• The machine does not operate with any ink other than the Tx500 genuine ink.</li> <li>• Do not use the Tx500 genuine ink with other printers, as doing so may cause damage to such machines.</li> <li>• Do not refill the ink in the bottle.</li> <li>• If the ink bottle is moved from a cold place to a warm place, leave it in the room temperature for three hours or more before using it.</li> <li>• Open the ink bottle just before installing it in the machine. If it is opened and left for an extended period of time, normal printing performance of the machine may not be ensured.</li> <li>• Make sure to store ink bottles in a cool and dark place.</li> <li>• Store ink bottles and waste ink tank in a place that is out of the reach of children.</li> <li>• Be sure to thoroughly consume the ink in the ink bottle, once it is opened, within three months. If an extended period of time has passed away after opening the ink bottle, printing quality would be poor.</li> <li>• Neither pound the ink bottle nor shake it violently, as doing so can cause leakage of ink.</li> <li>• Do not touch or stain the contacts of the IC chip, as doing so may cause damage to the print circuit board.</li> <li>• Waste ink is equivalent to waste oil of industrial waste. Request an industrial waste disposal company for disposal of waste ink.</li> </ul>	<ul style="list-style-type: none"> <li>• Never open the front cover during printing. Opening the cover will abort printing.</li> </ul>
	<b>Handling of media</b>
	<ul style="list-style-type: none"> <li>• Use media recommended by MIMAKI to ensure reliable, high-quality printing.</li> <li>• Pay attention to the expansion and contraction of the media. Do not use media immediately after unpacking. The media can be affected by the room temperature and humidity, and thus it may expand and contract. The media have to be left in the atmosphere in which they are to be used for 30 minutes or more after unpacked.</li> <li>• When using a fabric with curling, be sure to remove the curling before using. Strong curling may effect on the quality of printing or may hit the head nozzle surface and may cause discharging defect.</li> <li>• Do not leave the media with the heater ON for a long time.</li> </ul>
	<b>Protection of media from dust</b>
	<ul style="list-style-type: none"> <li>• Store media in a bag. Wiping off dust accumulated on media will adversely affect the media due to static electricity.</li> <li>• When leaving the workshop after the working hours, do not leave any media on the roll hanger. If any media is left on the roll hanger, it can get dusty.</li> </ul>

 <b>Warning</b>	
<b>Notes on maintenance</b>	
<ul style="list-style-type: none"> <li>• It is strongly recommended to use the machine in a room that is not dusty.</li> <li>• Keep the front cover closed even when the machine is not printing. If not, dust can accumulate on the nozzles in the heads.</li> <li>• Dust in the heads can also cause drops of ink to fall suddenly down on the media during printing. In such a case, be sure to clean up the heads. (P.4-15 "Cleaning the Head and the Area around It")</li> <li>• When cleaning the ink-station or the heads, make sure to wear the attached gloves.</li> <li>• Perform wiping (removal of dust and paper powder) of the capping station and wiper frequently.</li> </ul>	
<b>Periodic replacement parts</b>	
<ul style="list-style-type: none"> <li>• Some parts of this machine must be replaced with a new one periodically by service personnel. Be sure to make a contract with your distributor or dealer for After sale service to ensure a long life of your machine.</li> </ul>	
<b>Disposition of this machine</b>	
<ul style="list-style-type: none"> <li>• When discarding this machine, request the treatment of it for an industrial waste disposal contractor.</li> <li>• Treat it properly in compliance with regulation in the local area.</li> </ul>	

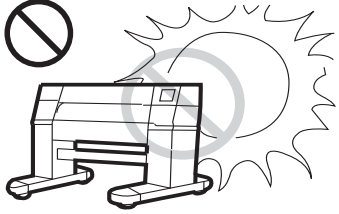
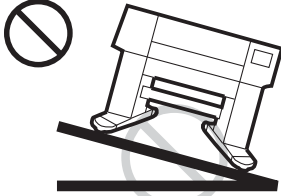
## Cautions on Installation

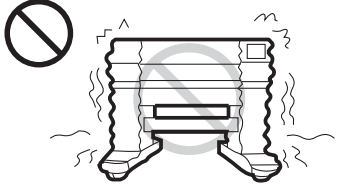
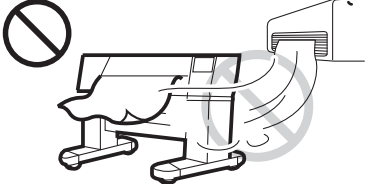
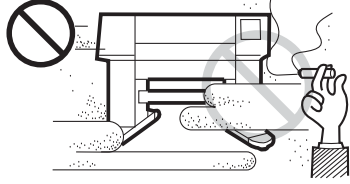
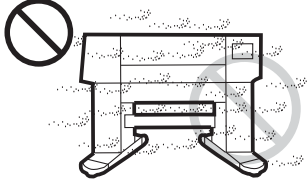
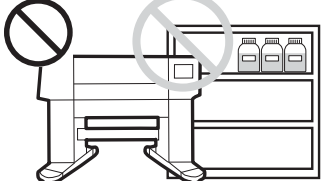
 <b>CAUTION</b>		
<b>A place exposed to direct sunlight</b>	<b>On an inclined surface</b>	<b>A place where temperature or humidity varies significantly</b>
		 <ul style="list-style-type: none"> <li>• Use the machine under the following environmental conditions:</li> <li>• Operating environment: 20 to 30 °C (68 to 86 °F) 35 to 65 % (Rh)</li> </ul>
<b>A place that vibrates</b>	<b>A place exposed to direct air flow from an air conditioner or the like.</b>	<b>Around a place where fire is used</b>
		
<b>A place with much dust</b>	<b>A place with chemicals around</b>	
		

## Safety interlock

This machine is equipped with interlocks to terminate the operation for your safety when the cover opens during printing etc. (red circle parts in the figure below).

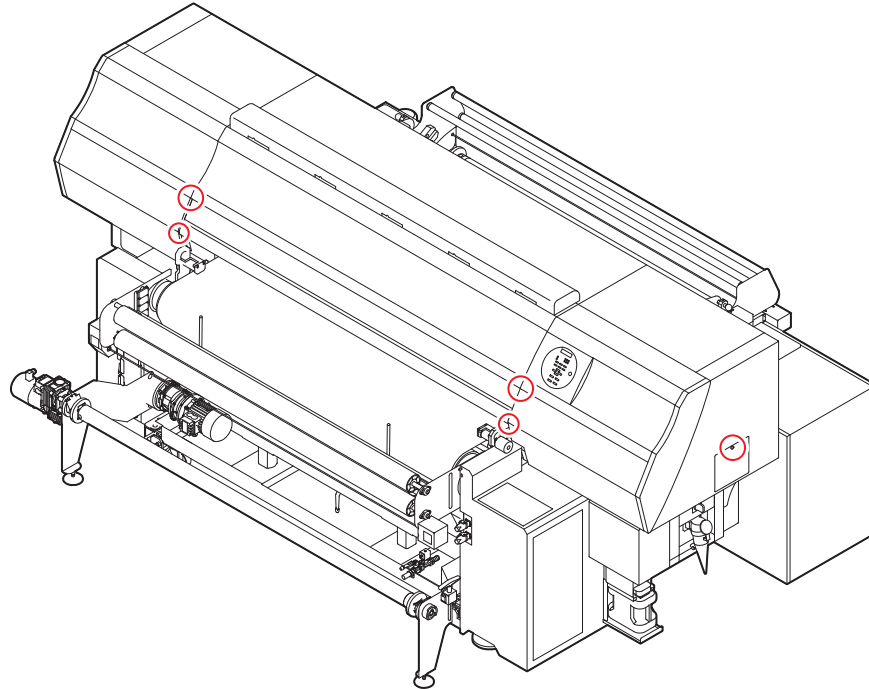

## Emergency switch

This is the switch for stopping the machine emergently for safety reason.  
The emergency switches have 2 types "button-switch" and "wire type-switch".

### How to use the emergency button-switch

**1**

Press the emergency button-switch when the emergency case occurs.

Emergency buttons (Red switches) are located on the front and back operation panels of the media feeding part, and on the power unit of the media feeding part.

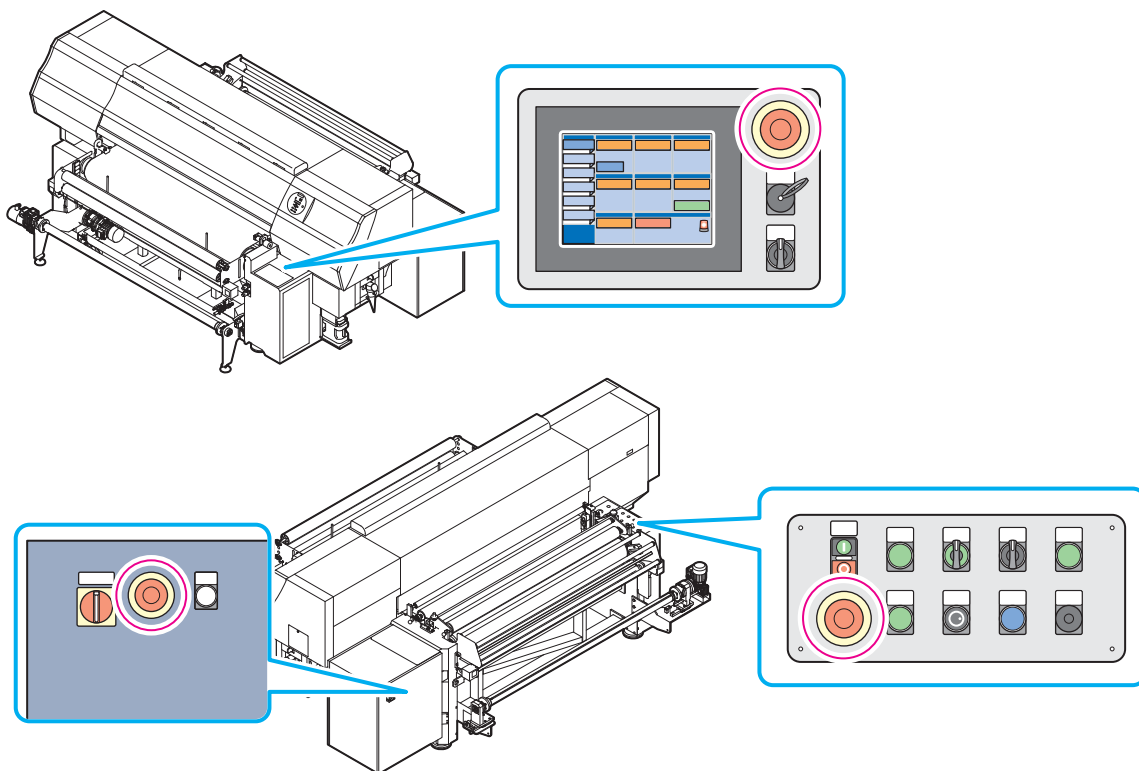

---

**2**

After the machine stops, remove the cause of the defect and confirm the safety.

---

**3**

Release the emergency stop.

- Rotate the emergency button to release.

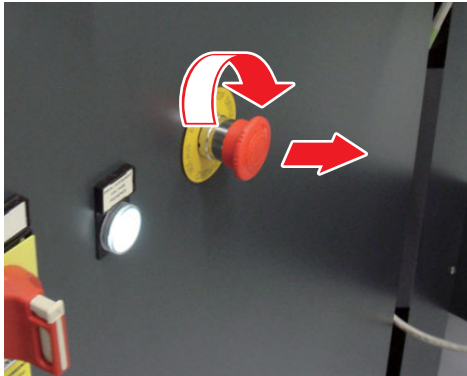

## How to use the emergency wire-switch

**1**

**Pull the emergency wire-switch when the emergency case occurs.**

- The emergency wire switch (Red wire) locates along with the roller of front side and back side.
- Pull the wire strongly to the downward or your side.

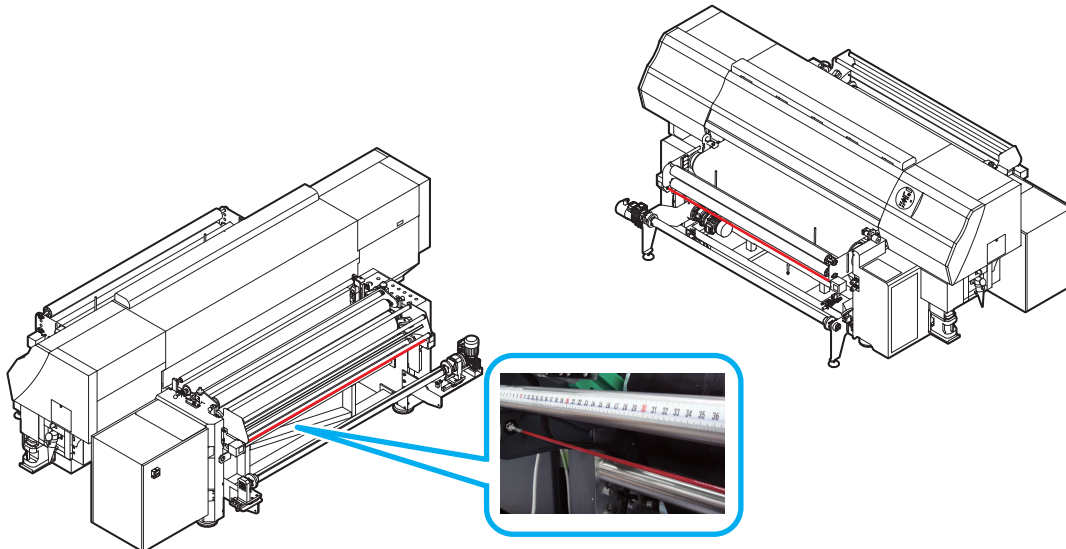

**2**

**After the machine stops ,remove the cause of the defect and confirm the safety.**

**3**

**Release the emergency stop.**

- Release by pressing the blue button located on the side of the machine.

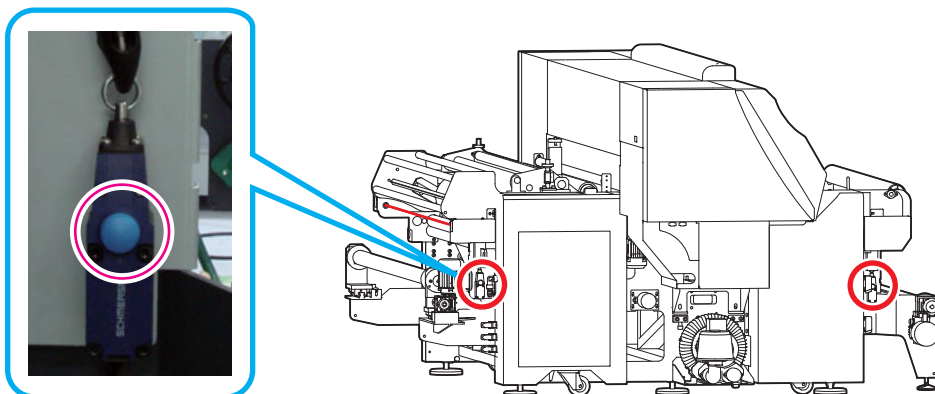

## EC DECLARATION OF CONFORMITY

We hereby declare that the following our products conform with the essential health and safety requirements of EC Directives.

Product	Color Inkjet Printer	
Model No.	Tx500-1800B	
Serial No. covered	AABCDEEE AA: W3, B: 0 to 9, C: any alpha-numeric, D: any alphabet, EEE: 001 to 999	
Manufacturer	MIMAKI ENGINEERING CO.,LTD. 2182-3, Shigeno-otsu, Tomi, Nagano, 389-0512, JAPAN	
Authorised Compiler in the Community	MIMAKI EUROPE B.V. Stammerdijk 7E 1112 AA Diemen, The Netherlands Managing Director Koji Shimizu	
Directives	Machinery Directive	2006/42/EC
	Low Voltage Directive	2014/35/EU
	EMC Directive	2014/30/EU
	RoHS Directive	2011/65/EU

The above products have been evaluated for conformity with above directives using the following European standards. The technical construction file (TCF) for this product is retained at the above Manufacturer's location.

Machinery Directive / Low Voltage Directive

EN ISO12100:2010, EN60204-1:2006+A1, EN60950-1:2006+A11+A1+A12

EMC Directive EN55022:2010, EN61000-3-2:2006+A1+A2, EN61000-3-3:2008, EN55024:2010

RoHS Directive EN50581:2012



# Chapter 1

## Before Use



### This chapter

describes the items required to understand before use, such as the name of each part of the machine or the installation procedures.

About installing this machine .....	1-2	Setting up .....	1-11
Where to Install This Machine .....	1-2	Setup of media feeding part .....	1-11
Working Environmental Temperature .....	1-2	Connecting Cables .....	1-15
About fixing machine .....	1-3	Connecting USB2.0 Interface Cable .....	1-15
Moving This Machine .....	1-3	Connecting Power Supply Cable .....	1-16
Names of Parts and Functions .....	1-4	Setting ink bottles .....	1-17
Front Side of the Machine .....	1-4	For ink .....	1-22
Rear Side and Right Side of the Machine ...	1-5	Ink type .....	1-22
Operation Panel .....	1-6	Caution in handling of ink bottles .....	1-22
Operation Touch Panel .....	1-7	Media .....	1-23
Operation Panel (Front surface of media feeding part) .....	1-8	Usable Sizes of Media .....	1-23
Operation Panel (Rear surface of media feeding part) .....	1-9	Precautions in handling the fabric .....	1-23
Power of media feeding part .....	1-9	Limited media .....	1-23
Carriage .....	1-10		
Indicator .....	1-10		
Capping station .....	1-10		

# About installing this machine

## Where to Install This Machine

Secure a suitable installation space before assembling this machine.

The place of installation must have enough space for not only this machine itself, but also for the printing operation.

Model	Width	Depth	Height	Gross weight
Tx500-1800B	3895mm	2750mm	1640mm	1840kg

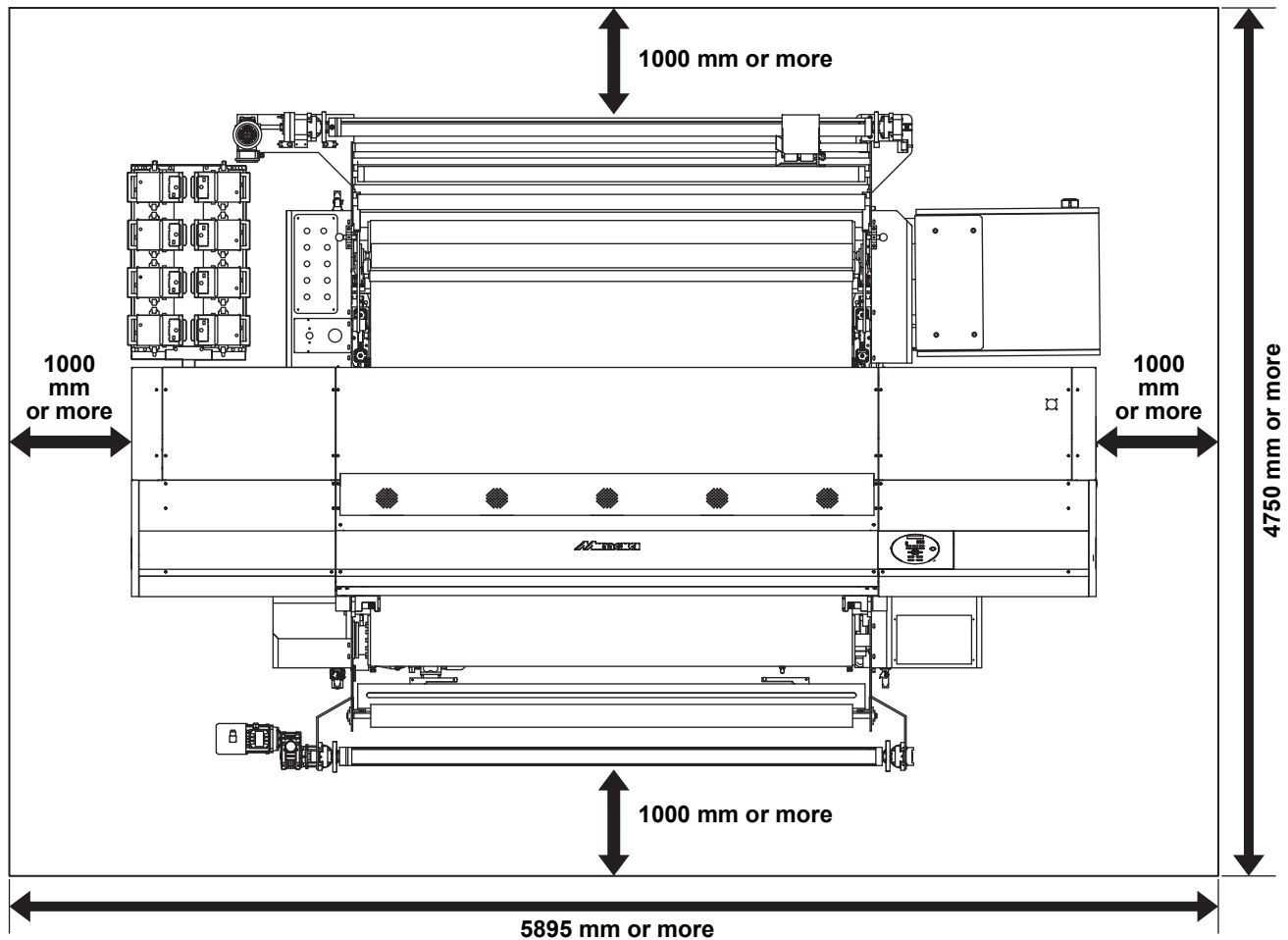

## Working Environmental Temperature

Use this machine in an environment of 20 to 30°C to ensure reliable printing.

The heater temperature may not reach the set value, depending on the ambient temperature.

## About fixing machine

The leg of this machine has the adjuster foot to fix the machine.

Before turning the power ON, make sure that the printer body is fixed with the leveling feet. The printer body may start moving during operation if it is not fixed with the leveling feet.

Top view

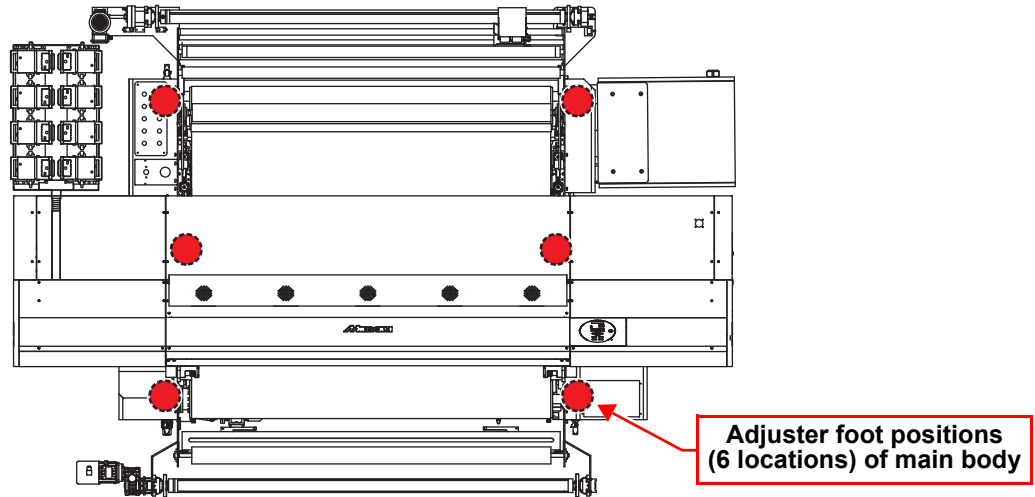

1

Before Use

## Moving This Machine

**Important!**

- When the machine is moved to any place other than on the same step-free floor, contact your distributor or our service office.  
If you move it by yourself, failure or damage may occur.  
Be sure to request your distributor or our service office to move this machine.

# Names of Parts and Functions

## Front Side of the Machine

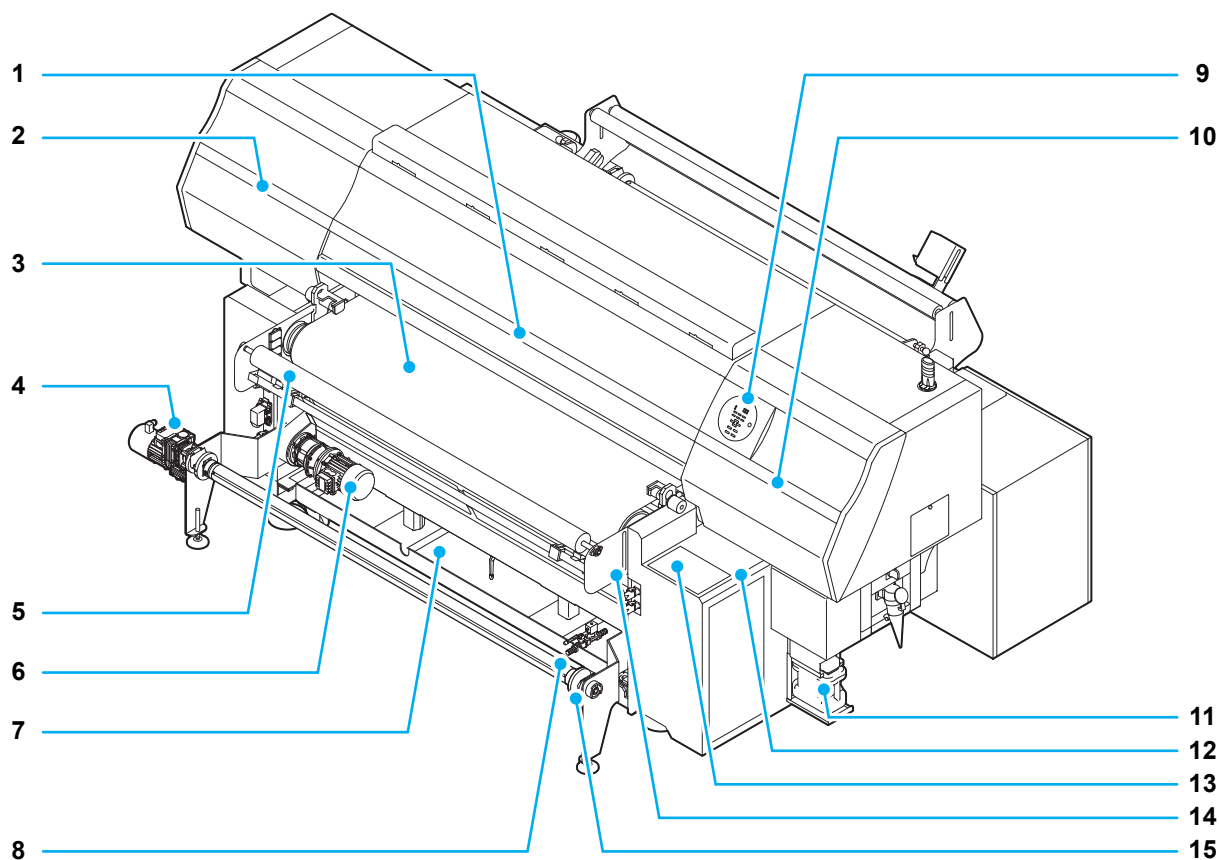

	Name	Function
(1)	Front cover	Open the cover in setting of medias, taking of measures against jamming of medias or in maintenance inside the station. Even when the power button is off, keep this cover and the other covers closed.
(2)	Left maintenance cover	Open the cover in maintenance. Even when the power button is off, keep all covers closed.
(3)	搬送ベルト	Carrying cloths.
(4)	Take-up unit	Unit to take up the printed fabric.
(5)	Peeling roller	Peels the fabric from the feeding belt.
(6)	Washing brusher motor	Rotating the brush for belt washing.
(7)	Belt washing unit	Washes ink, lint, etc. adhering to the belt surface with water.
(8)	Water valve	Pipe to supply the belt washing water.
(9)	Operation panel	This panel has the operation keys required for operating the machine and the LCDs for displaying setting items, etc.
(10)	Right maintenance cover	Open the cover in maintenance.
(11)	Waste ink tank	Waste ink gathers in this tank.
(12)	Operation panel (Front)	There are buttons for manual/automatic operations of take-up unit, and the [Emergency] button.
(13)	Operation touch panel	Panel to display operation keys to perform setting required to this machine and operation items.
(14)	Peeling sensor	Monitors the position to peel the fabric.
(15)	Roll holder	Supports the paper core of two to three inches.

**Rear Side and Right Side of the Machine**

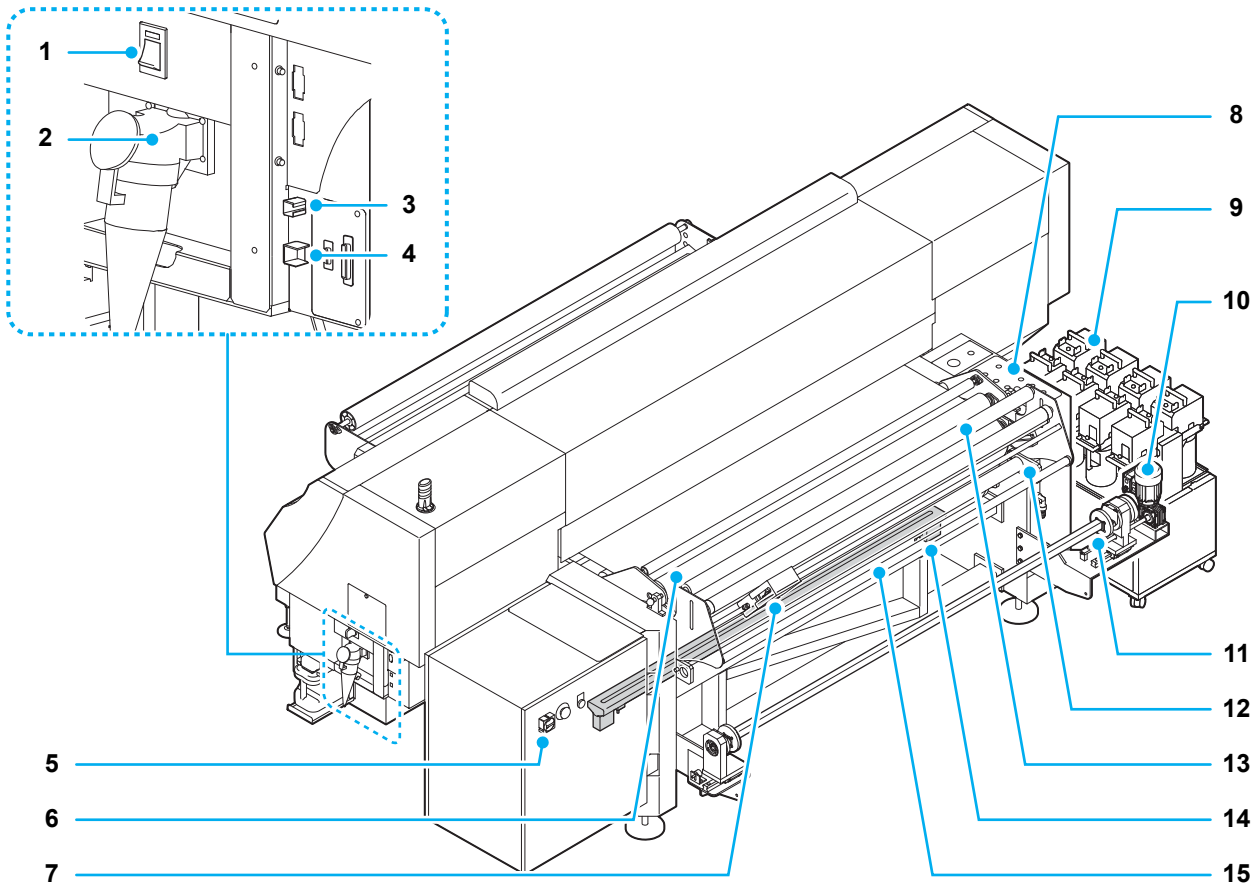

**1**  
Before Use

	Name	Function
(1)	Power switch on printer side	The power switch of the printer.
(2)	AC inlet	Connect the power cable of the printer part.
(3)	USB 2.0 connector	This is USB2.0 interface connector.
(4)	LAN connector	Please use this connector when you use event mail function.
(5)	Power switch for the media feeding part	Power switch of the media feeding part.
(6)	Pressure Roller	Places the pressure and attaches the media on the feeding belt.
(7)	Centering sensor / Media end sensor	Detects weaving of the media and changes its operation to the centering operation. Detects the media end with the sensor.
(8)	Operation panel (Rear)	You can perform manual/automatic operation of the centering unit, the pressure roller, etc. At the media setting, you can operate without moving to the operation panel (front).
(9)	External ink supply unit	Set the ink bottle.
(10)	Feeding unit	Unit to feed the roll media before printing.
(11)	Roll holder	Supports the paper core of two to three inches.
(12)	Smoothing wrinkle roller	Smooths wrinkle of the fabric.
(13)	Fabric winding roller	Sucks remaining water drops on the feeding belt. It is required to change the wound fabric periodically.
(14)	Belt heater	Increasing the adhesive strength of anti-wrinkling agent by heating the belt.
(15)	Air blade	Removing water droplets by blowing the air to the belt.

# Operation Panel

Use the operation panel to make settings for printing or operate this machine.

## ACTIVE lamp

When the power supply is turned on, it lights.

## Display

Displays the status of the machine, set items and errors.

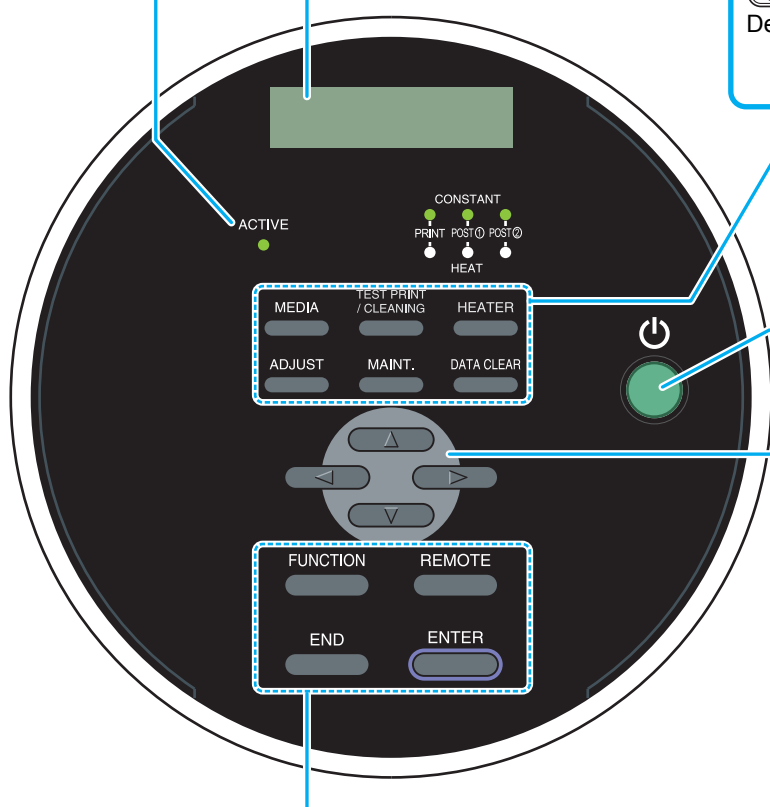

## MEDIA key

Use this when setting the head gap.

## TEST PRINT/CLEANING key

Draws test patterns to check if there are any drawing failures such as ink clogging. Or executes Head cleaning at ink clogging.

## ADJUST key

Performs the adjusting function such as "Drop.POScorrect" and "Feed COMP."

## MAINT. key

Performs the maintenance function such as station maintenance.

## DATA CLEAR key

Deletes the data that have been received.

## power button \*1

Turns on/off the power of printer part of this machine.

## JOG key

Use these keys to shift the carriage or the media in [LOCAL]. Also use them to select an item of printing conditions.

## FUNCTION key

Use this key to display function setting menu.

## END key

Cancels the last input value or returns the setting menu to the immediate higher level of the hierarchy.

## REMOTE key

Use this key to switch between [REMOTE] and [LOCAL].

## ENTER key

Registers the last input value as the setting value or goes to the immediate lower level of the hierarchy.

\*1 : When the power supply button is turned ON, it lights in green, and when it is OFF, it goes out. The ink clogging prevention function is periodically operated even when the power button is OFF if the main power switch keeps being ON. (Auto maintenance function) P.1-5

# Operation Touch Panel

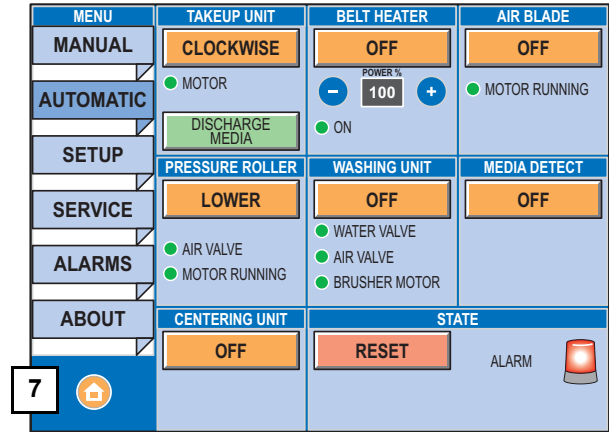
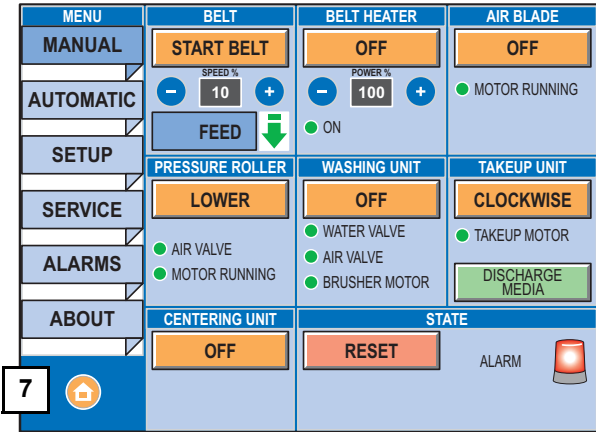

## Function

(1)	MANUAL	Displaying the “MANUAL” screen. In the “MANUAL” screen, the belt is operable with no operation of the printer part.
(2)	AUTOMATIC	Displaying the “AUTOMATIC” screen. In the “AUTOMATIC” screen, the belt is operable in conjunction with the printer part.
(3)	SETUP	Displaying the “SETUP” screen. The language setting of the touch-panel and the setting of each function can be performed.
(4)	SERVICE	Displaying the “SERVICE” screen. The screen is used when applying the anti-wrinkling agent or washing the belt.
(5)	ALARMS	Displaying the content of alarm of the media carrying unit. Cancel the alarm according to the contents of this document.
(6)	ABOUT	The firmware version of the media feeding part can be confirmed.
(7)	HOME BUTTON	Returning to the “AUTOMATIC” screen by pressing the home button.
(8)	BELT	Making the media carrying belt operate. The belt moves by pressing [START BELT]. The belt stops by pressing [STOP BELT]. The operating speed and operating direction of belt can be set.
(9)	BELT HEATER	Making the belt heater operate. The belt heater is actuated by pressing [ON]. The belt heater stops by pressing [OFF]. The output of belt heater can be set.
(10)	AIR BLADE	Making the air blade operate. The air blade is actuated by pressing [OFF]. The air blade stops by pressing [ON].
(11)	PRESSURE ROLLER	Operating the pressure roller up/down. The pressure roller goes down by pressing [LOWER]. The pressure roller goes up by pressing [RAISE].
(12)	WASHING UNIT	Making the washing unit operate. The washing unit is actuated by pressing [OFF]. The washing unit stops by pressing [ON].
(13)	TAKEUP UNIT	Setting the rotating direction of the take-up motor. The media shaft automatically rotates up to the position where the media shaft is removable when pressing [DISCHARGE MEDIA].
(14)	MEDIA DETECT	Making the media detecting function enable/disable. The media end sensor checks the media end by pressing [OFF]. The media end sensor does not function by pressing [ON].
(15)	CENTERING UNIT	Making the centering function enable/disable. The feeding unit adjusts the media position at the media feeding by pressing [OFF].
(16)	STATE	Cancelling the media width detecting of the printer part by pressing [RESET]. When the alarm is in red, an error is occurring in the media carrying unit. Check the content of alarm on the alarm screen.

1 Before Use

## Operation Panel (Front surface of media feeding part)

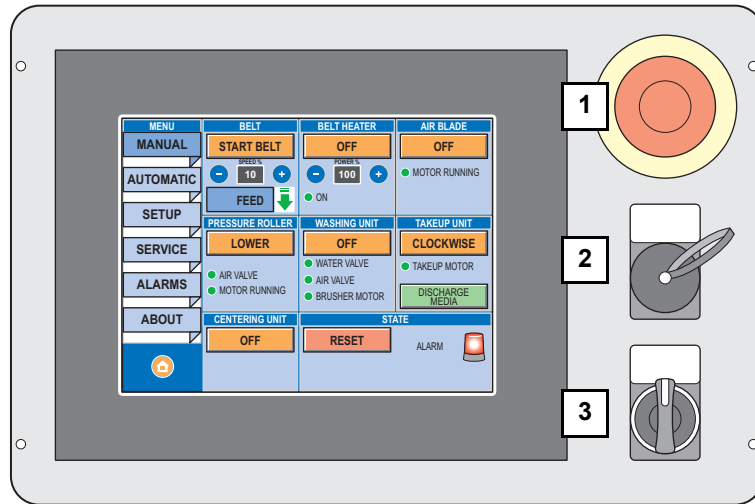

	Name	Function
(1)	[Emergency] button	Immediately stop this machine under operation.
(2)	USB connector	USB connector for the service maintenance. Not available for a customer.
(3)	[TAKE-UP MANUAL] lever	Turns the take-up motor in the direction of the lever.



**Operation Panel (Rear surface of media feeding part)**

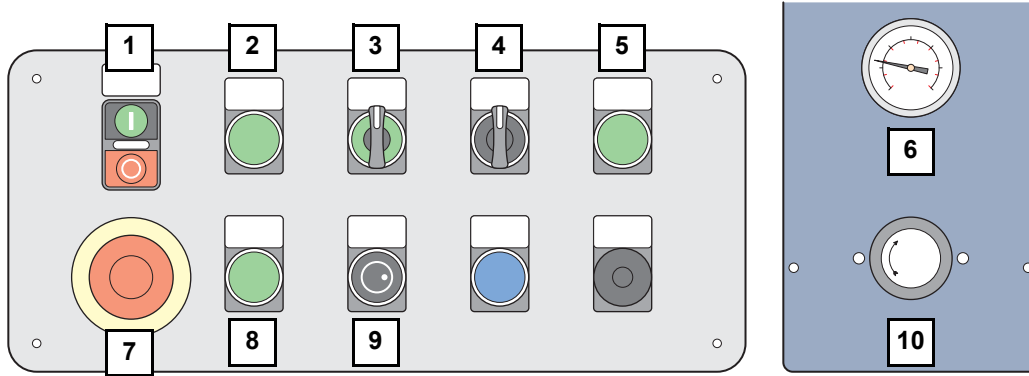

	Name	Function
(1)	[BELT] button	When you press "I", the belt will move, and when you press "O", it will stop.
(2)	[FEED BACKFEED] button	When the green light turns off by pressing, the moving direction of the belt is changed in the direction of feed back.
(3)	[CENTERING MANUAL] lever	Rotating to right or left, adjust the media position manually. In the AUTOMATIC mode, you cannot adjust even if you operate the lever. After adjusting the position in the MANUAL mode, change to the AUTOMATIC mode.
(4)	[PRESSURE ROLLER UP DOWN] lever	The roller goes up by rotating to the "UP" side, and goes down by rotating to the "DOWN" side.
(5)	[MEDIA END] switch	When it lights in green by pressing this, the media end detection becomes valid.
(6)	Air pressure gauge	Displays the pressure of the pressure roller.
(7)	[Emergency] button	Immediately stops this machine under operation.
(8)	[AUTOMATIC] lamp	When it is in the AUTOMATIC mode, this lights in green.
(9)	[CLUTCH TUNING] dial	Adjusting the rotating friction of the feeding media.
(10)	Air pressure adjusting dial	Adjusts the pressure of the pressure roller.

1 Before Use

**Power of media feeding part**

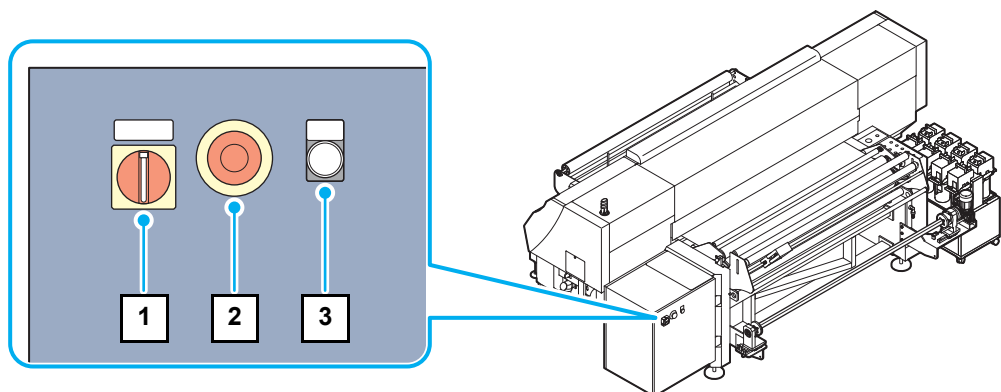

	Name	Function
(1)	Power switch of the media feeding part	Turning on/off the power of the media feeding part.
(2)	[Emergency] button	Immediately stops this machine under operation.
(3)	[POWER ON] lamp	At lighting up, representing that the power of the media feeding part is in "ON".

## Carriage

The carriage is provided with the heads for printing.

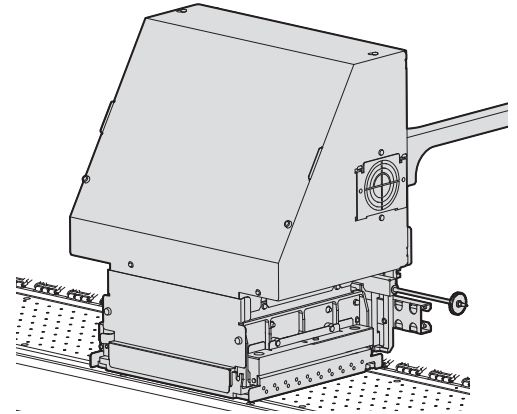

## Indicator

Functions of the Indicator on the top right of this unit are described here.

The indicator has a green and a red lamp.

Color of lamp	State of lamp	State of machine
Green	Lighting	REMOTE
	Blinking	REMOTE (printing)
	Off	LOCAL
Red	Lighting	Error has occurred (system down)
	Blinking	Error or warning has occurred
	Off	Normal

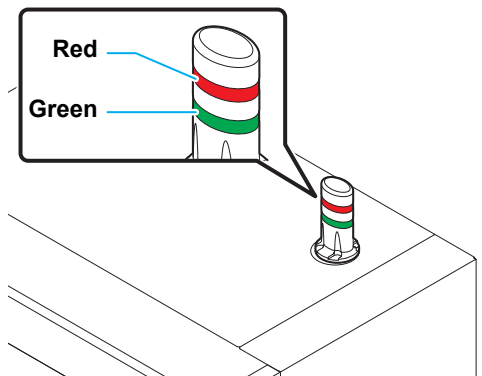

## Capping station



- Be sure to wear the attached goggles in cleaning within the capping station to protect your eyes against ink. Otherwise, you may get ink in your eyes.

The capping station consists of the ink caps, the wiper for cleaning the heads, etc.

The ink caps prevent the nozzles in the heads from drying up.

The wiper cleans the nozzles in the heads.

The wiper is consumable. If the wiper is deformed or the media is stained, replace the wiper with a new one. (☞ P.4-26)

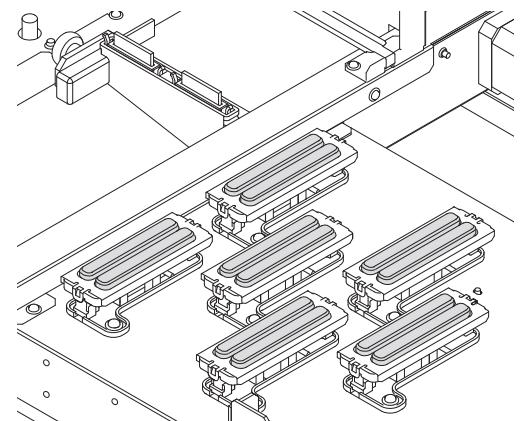

# Setting up

## Setup of media feeding part

You can set the following items in Setup.

Pressing the [SETUP] button on the operation touch panel, perform the setting.

- Setting of language to be displayed on the operation touch panel
- Normal setting
- Setting of each function

### Language setting

- 1 Press the [SETUP] on the operation touch panel.

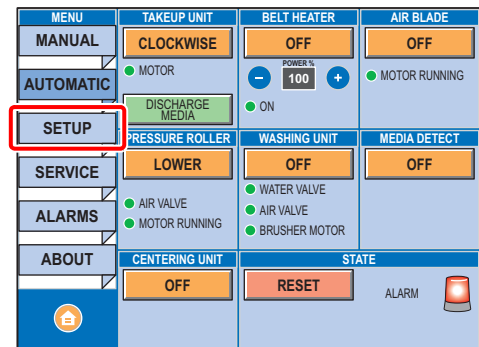

- 2 Press the [SETUP] on the operation touch panel.

- If you wish to cancel, press the [BACK].

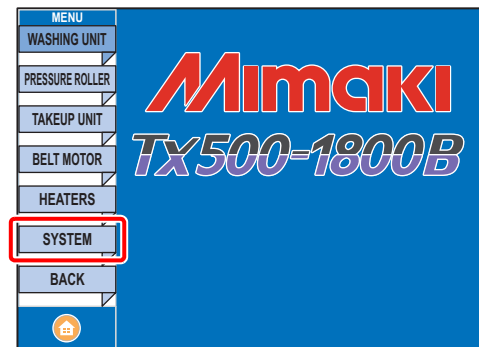

- 3 Press the [LANGUAGE].

- If you wish to cancel, press the [BACK].

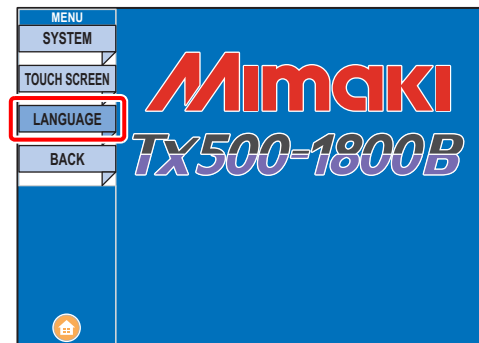

---

**4**

**Select language to be displayed.**

- Selectable language : ENGLISH, ITALIAN, GERMAN  
JAPANESE, CHINESE, FRENCH
- If you wish to cancel, press the [BACK].

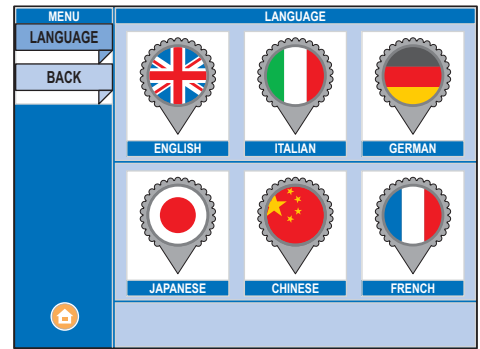

---

**5**

**Return to the “AUTOMATIC” screen by pressing the home button.**

---

## Setting of each function

MENU Name	Function Name	Item Name	Content
WASHING UNIT	WASHING UNIT	ENABLED/ DISABLED	Setting whether the belt washing is used or not. If setting to the enabled state, the take-up unit is useable. Also, the belt washing is turned on automatically by displaying the "AUTOMATIC" screen.
		DETACH AFTER	Setting the lowering timing of the belt washing unit. After the belt washing unit goes up, the time from the stopping of belt to the lowering of belt washing unit is set. This setting is indicated in minutes.
	BRUSHER MOTOR	DETACH AFTER	Setting the stopping timing of the brusher motor. After the brusher motor is operated, the time from the stopping of belt to the stopping of brusher motor is set. This setting is indicated in minutes.
		SPEED	Setting the rotating speed of brusher motor. This value is indicated in operating percentages.
	AIR BLADE	ENABLED/ DISABLED	Setting whether the air blade is used or not. If setting to the enabled state, the air blade is useable.
		DETACH AFTER	Setting the timing until the air blade stops. After the air blade is operated, the time from the stopping of belt to the stopping of air blade is set. This setting is indicated in minutes.
	WATER VALVE	OPEN EVERY	Setting the opening timing of the water valve. After the water valve closes, the time until the valve automatically opens is set. This setting is indicated in minutes.
		STAY OPEN FOR	Setting the closing timing of the water valve. After the water valve opens, the time until the valve automatically closes is set. This setting is indicated in minutes.
PRESSURE ROLLER	PRESSURE ROLLER	DETACH AFTER	Setting the rising timing of the pressure roller. After the pressure roller is lowered, the time from the stopping of belt to the rising of pressure roller is set. This setting is indicated in minutes.
	PRESSURE ROLLER MOTOR		Unable to be set due to the function unused in this machine.
TAKEUP UNIT	TAKEUP UNIT	ENABLED/ DISABLED	Setting whether the take-up unit is used or not. If setting to the enabled state, the take-up unit is useable.
		CLOCKWISE	Setting the rotating direction of take-up motor.
	TAKEUP MOTOR		Unable to be set by a customer due to the item used for the service maintenance.
BELT MOTOR	PARAMETER		Unable to be set by a customer due to the item used for the service maintenance.
HEATER	BELT HEATER	POWER	Setting the temperature of belt heater. This value is indicated in operating percentages.
		DETACH AFTER	Setting the timing until the belt heater stops. After the belt heater is operated, the time from the stopping of belt to the stopping of belt heater is set. This setting is indicated in seconds.

**1** Press the [SETUP] on the operation touch panel.

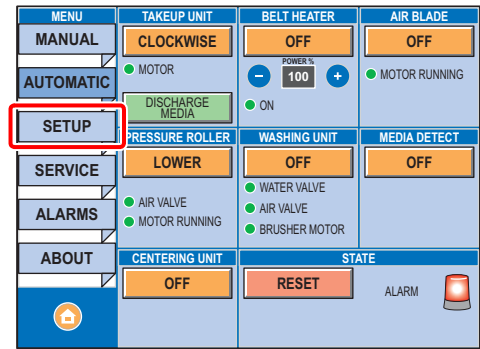

**2** Press the item button of “MENU” to be set.  
 • If you wish to cancel, press the [BACK].

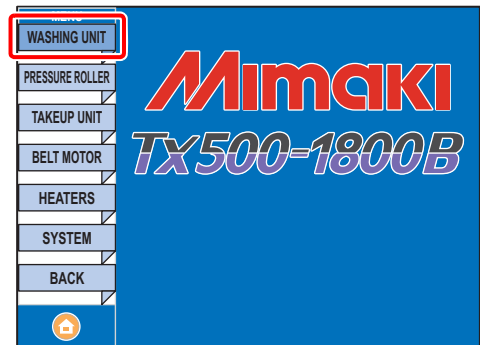

**3** Set by pressing the item to be set, or [+] / [-].  
 • If you wish to cancel, press the [BACK].

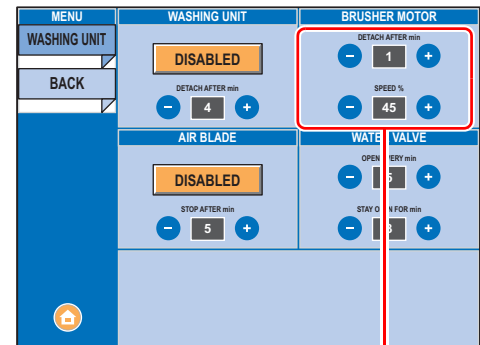

Press the [+] / [-] of the item to be set.

**4** Return to the “AUTOMATIC” screen by pressing the home button.

# Connecting Cables

## Connecting USB2.0 Interface Cable

Connect the PC and this machine with the USB2.0 interface cable.



- Your RIP must be compatible with USB 2.0.
- Contact a RIP maker near your location or our office when the USB2.0 interface is not attached to the PC.

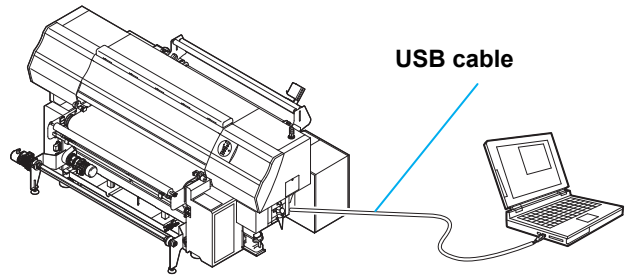

## Notes on USB 2.0 Interface



- Your RIP must be compatible with USB 2.0.

### ● When two or more Tx500 machines are connected to one personal computer

When two or more Tx500 machines are connected to one personal computer, the personal computer may not recognize all the Tx500 machines normally.

Reconnect the unrecognized Tx500 machine to another USB port, if available, and check to see if it is recognized. If the Tx500 machine is not recognized by the newly connected USB port, use USB 2.0 repeater cables available on the market.

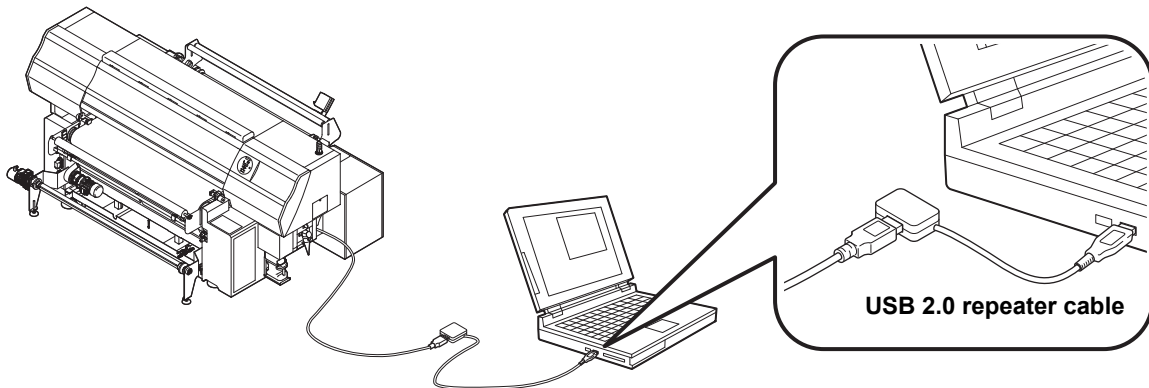

### ● Notes on peripheral devices in USB high speed mode

When a peripheral device (USB memory or USB HDD) to be operated in USB high speed mode is connected to the same personal computer that a Tx500 machine is connected to, the USB device may not be recognized.

When Tx500 is connected to the personal computer to which an external HDD is connected via USB, the speed of data output to Tx500 may drop. That can cause the head unit to stop temporarily at the right or left end during printing.

## ● Removing USB memory

If a USB memory module is inserted in the personal computer to which a Tx500 machine is connected, click "Stop" in the "Safely Remove Hardware" window by following the instructions given there first and then remove the module.

Leaving a USB memory module inserted can cause [ERROR 201 COMMAND ERROR].  
Copy the data onto the hard disk before outputting it for printing.

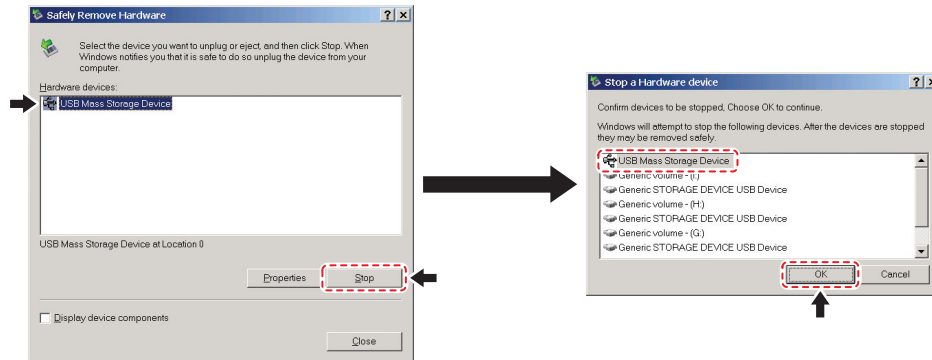

## Connecting Power Supply Cable

Connect the power cable to the distribution board with the following specifications.

<b>Power voltage</b>	AC380-420V $\pm$ 10%
<b>Frequency</b>	50/60Hz $\pm$ 1Hz
<b>Capacity</b>	20A and above



- 100V system outlet cannot be used.



- You cannot perform the installation of this machine. Request an electrician for doing the installation work.
- The following electrical work is required for power supply to the main body. Request an electrician for the work.
  - Socket work to the breaker
  - C type grounding work (Special 3rd type grounding work)
- Make sure that the power breaker is placed close to the machine so that the power can be shut down easily when necessary.
- Doing the electrical work of this machine by other than a person who has the license of the electrical work is prohibited to prevent the electric shock.
- Be careful not to perform faulty wiring. It may cause fire or electric shock.
- Make sure to connect the power cable to the distribution board that is grounded. Otherwise, it may cause electric shock or damage of this machine.
- Make sure that the power breaker supports the incoming currents of 50A/0.01 second and faster before connecting.



# Setting ink bottles

Set the ink bottle on the external ink supply unit.

## 1 Remove the ink cover.

- Remove both catches of the ink cover and remove the cover.
- The rear surface of the ink cover has the nozzle (stick shape) for ink absorption and the float sensor for detecting remaining amount of ink.

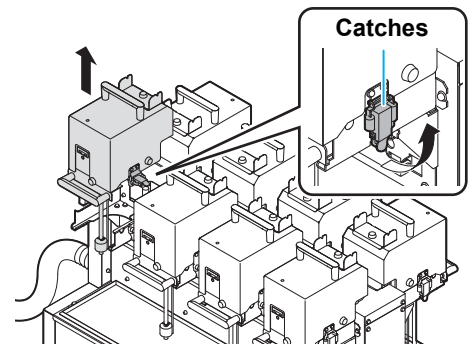
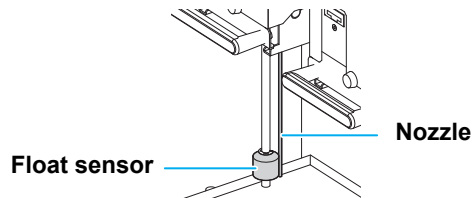

## 2 Put the removed ink cover on the ink cover of the rear surface side.

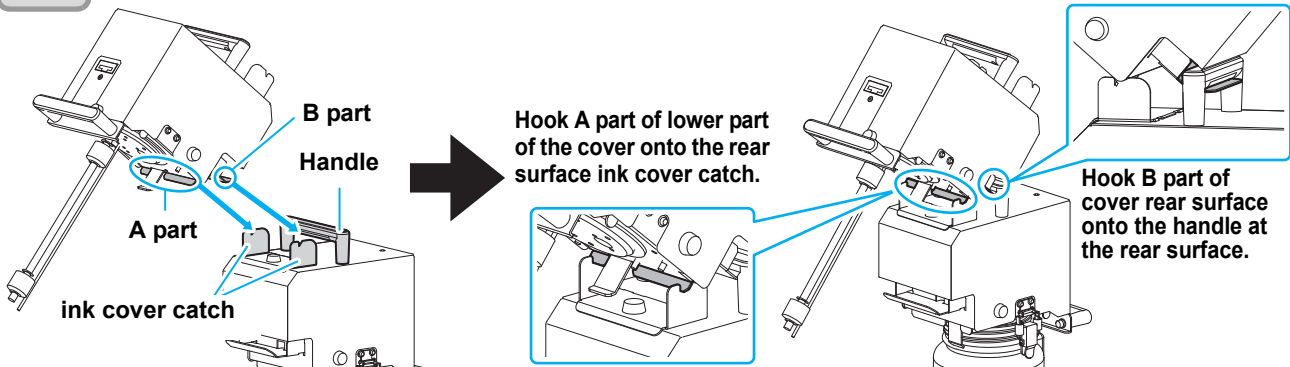

## 3 Take out the ink bottle, and slowly shake it twenty times and more.

- To prevent ink from leaking when you shake it, wear gloves and cover the ink bottle cap with a paper towel etc. Being in that status, slowly shake it twenty times and more by flowing ink.



- If you shake it too strong, it may cause ink leakage. Therefore, perform this carefully.
- If the remaining amount of ink is less, ink in the bottle cannot be beaten enough. Tilt the ink bottle until it becomes vertical.

Before shaking it, check that the cap is firmly closed.

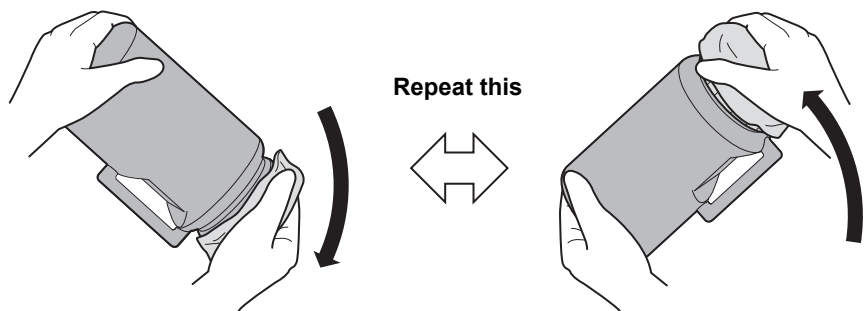
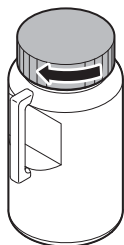

Cover with paper towel firmly and shake ink slowly

## 4 Remove the cap of the ink bottle.

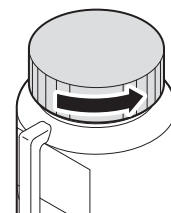

1

Before Use

**5****Make slits in the top surface of the bottle as the figure, and push the aluminum sheet downward.**

- Use a cutter etc. to make slits in the top surface.

**How to make slits**

- When you make slits in the aluminum sheet, divide it into eight parts as shown in the figure, or, cut off the aluminum sheet along the inner side of the bottle.

Divide into eight parts.

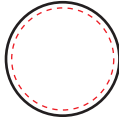
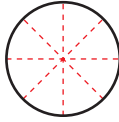

Cut off the inner side of the bottle (dotted-line part).

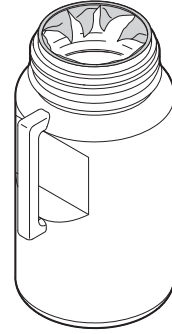
**6****Set the ink bottle on the bottle holder, and attach the ink cover.**

- Make the nozzle (stick shape) for absorbing ink and the float sensor for detecting remaining amount of ink so that they may be in the ink bottle.
- When ink plate gets dirty with ink etc., wipe it off with a waste cloth.

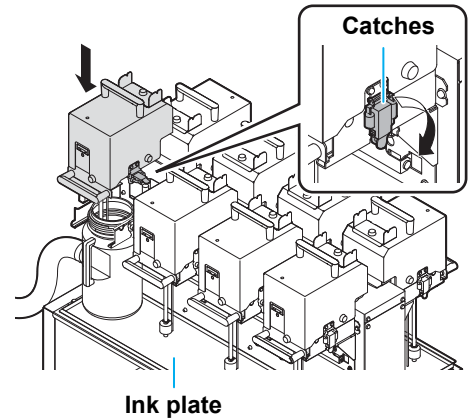
**7****Insert the IC chip.**

- Insert the IC chip with the surface with metal upward. If you insert the wrong side by accident, it causes faulty or damage of the IC chip.
- Do not touch the metal part of the IC chip. It may break the IC chip by static, or may cause read error by stain or flaw.
- For the setting orders of the ink bottles, refer to P.6-4.

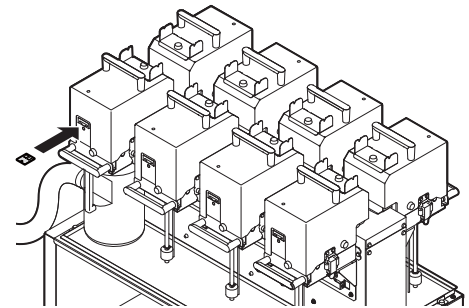

Important!

**About IC chip**

- The IC chip has information of ink color, remaining amount of ink, expiration data, etc.  
When setting the ink bottle, insert the IC chip packed with the ink bottle into the IC chip inserting port attached with the ink cover.
- If you set the IC chip not being the pair of the ink bottle, image quality defect etc. may occur.
- The mark indicating color information is pasted on the IC chip.

Ink color and indication mark

Ink color	Indication mark
Black	● (one black circle)
Blue	●● (one blue circle and one red circle)
Magenta	● (one red circle)
Yellow	● (one yellow circle)
Light blue	●●● (two blue circles and one red circle)
Light magenta	●● (two red circles)
Orange	● (one orange circle)
Red	●● (one red circles and one yellow circle)
Light black	●● (two black circles)

IC chip

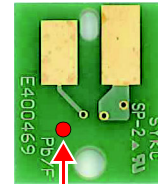

Mark indication position

## Changing an ink bottle

Perform as follows when [INK END] or [INK NEAR END] is displayed on the display.

### ● When [INK END] is displayed

#### 1 Remove the ink cover of the ink bottle to be changed, and remove the empty (used) ink bottle.



- Transfer any remaining ink into the new bottle. Make sure that no ink spills out from the ink bottle while doing so.
- When replacing the ink bottle, ink may spatter. Be careful not to get ink into your eyes.
- Before replacing the ink bottle, cover around it with a waste cloth etc. Ink may drop from the float part and may stain around the part.

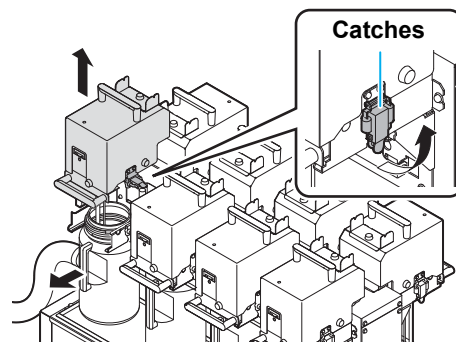

#### 2 Check the up/ down movement of the float.

- If there is an abnormality on the float movement because dry ink adhered to it etc., perform the following procedures:

(1) Place a few drops of washing liquid on the upper part of the float.

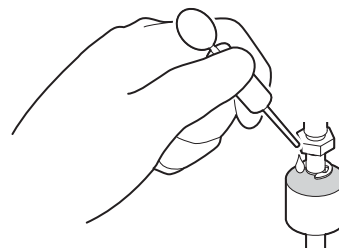

(2) Move the float up/ down to spread washing liquid evenly.

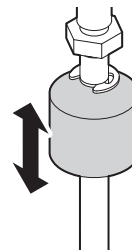

(3) When the float comes to move smoothly, wipe washing liquid adhering to the float and the pipe with a waste cloth etc.

- Move the float up/ down again and check that there is no abnormality.

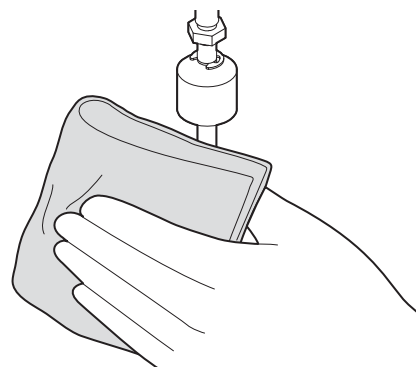

#### 3 Remove the cap of the new ink bottle, make slits in the top surface of the bottle as shown in the figure, and push the aluminum sheet downward.

- For the way to make slits in the aluminum sheet, refer to the Step 5 of "Setting ink bottles" (☞ P.1-18).

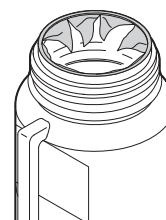

**4** Set the ink bottle on the ink holder, and attach the ink cover.

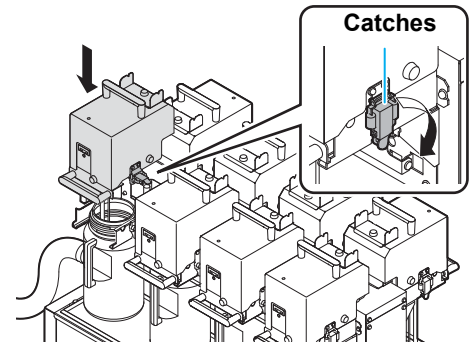

**5** Insert the IC chip.

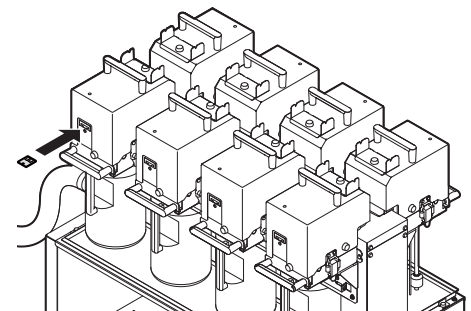

● **When [INK NEAR END] is displayed**

There is a little of ink left. It is recommended to replace the ink bottle soon since ink may become empty in printing while printing is continuously enabled. When you press the **ENTER** key in LOCAL, you can check the bottle to be replaced in the local guidance. (☞ P.3-43)



- There is approximately 200 cc of ink remaining in the bottle when [INK END] is displayed. Transfer the remaining ink into the new ink bottle when replacing the ink.

**For Ink bottle lamps**

The condition of the ink bottles set in the machine is confirmable with lamps located over the ink bottles.

Ink bottle lamps

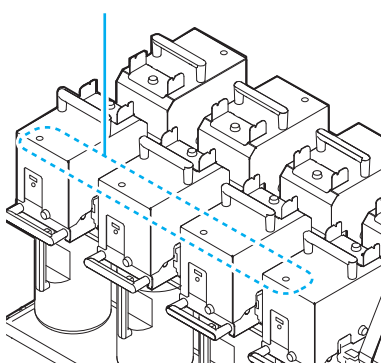

Condition of Ink bottle lamp	Description
OFF	No error
Blinks in red.	There is less ink in the ink bottle (Near End). Or, one month has passed from the expiration date of ink. It will become unusable soon.
Lights in red.	There is no ink in the ink bottle, or the ink bottle cannot be used due to other ink error. (☞ P.5-4)
Blinks in red (fast).	As two months have passed from the expiration date of ink, you cannot use the ink bottle.
Lights in green.	Indicates that ink is supplied. When you use four-color ink set, this machine first supplies ink from the ink bottle whose ink expires soon.
Blinks in red and green alternately.	It blinks in red and lights in green alternately.

## About ink expiration date

The ink bottle has its expiration date.

You can use the bottle in two months after the expiration date indicated on it, however, you cannot use it when three months have passed from the expiration date.

When it becomes unusable, the ink bottle lamp blinks fast in red to inform you of it. At this time, replace it with new one.

Ex.) When the expiration date is April 2014

May : Usable

June : Usable (Ink bottle lamp blinks in red.)

July : Unusable (Ink bottle lamp blinks fast in red.)

## About ink end and ink near end

When it becomes Ink near end (remaining amount of ink is less), the ink bottle lamp blinks in red to inform you of it. It is recommended to replace it with new one as soon as possible.

When it becomes Ink end (remaining amount of ink is none), the ink bottle lamp lights in red to inform you of it. Replace the ink bottle.

## Ink type

For this machine, the following three types of ink can be used:

<b>Acidic dye ink</b>	Suitable for fabric of animal type such as wool, silk, etc. and nylon.
<b>Reaction dye ink</b>	Suitable for fabric of wool, silk, etc. as well as cotton, rayon, etc.
<b>Sublimation dye ink</b>	Suitable for fabric of polyester, acrylic, etc.



- Whichever ink you use, be sure to perform pre-treatment and after-treatment that our company recommends to the fabric to be printed.

## Caution in handling of ink bottles



- If you get ink in your eyes, immediately wash your eyes with a lot of clean running water for at least 15 minutes. In doing so, also wash the eyes to rinse ink away completely. Then, consult a doctor as soon as possible.
- Use genuine ink bottles for this machine. This machine functions by recognizing the genuine ink bottles. In case of troubles caused by modified ink bottles or the like, it shall be out of the warranty even within the warranty period.
- If the ink bottle is moved from a cold place to a warm place, leave it in the room temperature for three hours or more before using it.
- Make sure to store ink bottles in a cool and dark place.
- Store ink bottles and waste ink tank in a place that is out of the reach of children.
- Request an industrial waste processor for processing of empty ink bottles.
- Be sure to thoroughly consume the ink in the ink bottle, once it is opened, within three months. If an extended period of time has passed away after opening the ink bottle, printing quality would be poor.
- Do not shake ink bottles violently. This may result in ink leakage from the ink bottles.
- Do not touch or stain the contacts of the IC chip. This may cause damages on printed circuit boards.



## Usable Sizes of Media

The media usable in this machine is as below:

Maximum width	1830mm
Minimum width	210mm
Maximum printing width	1820mm
Thickness	5mm or less
Roll outside diameter	φ 420mm
Roll weight	60kg or less
Roll inside diameter	2 ~ 3 inch
Print side	Regardless of faces out and in
Taking up direction	Regardless of faces out and in
Roll end treatment	Light-adhesive tape is used to allow the paper to be removed from the core with ease.
Setting position	Based on the center



- The belt encoder unit to feed the media correctly is attached on the right side of the media feeding part. Be careful not to make the media hanging over the position of 25mm from the right edge of the media feeding part.
- If you print with the media hanging over the belt encoder unit, the media cannot be fed correctly, and it may adversely affect the printing quality. Be careful especially when using wider media (the media with 1800mm and more width).

## Precautions in handling the fabric

Here, procedures and precautions in handling the usable fabric are explained.

Fully understand the contents and use depending on the kind or the characteristic of fabric.



- Use pre-processed fabric recommended by MIMAKI.
- When setting the fabric, be sure to adjust the head height. Other wise, the fabric and/or the head can be damaged.
- Do not use fabric with curled edges. Use of such a fabric may cause contact with the print head nozzle, resulting in inferior ink discharge.
- Do not use fabric whose edges are remarkably loose in comparison with the center. Crease occurs at the fixing section, which may come into contact with the head nozzle face.
- Thick hard fabric cannot be used for unattended operation. When using a denim-like fabric, skew check must be performed by the operator. Once skew starts, the self-restoration action of the fabric itself is disabled. If the fabric is neglected, skew advances to the right or left end of the belt which may cause head jam.
- Brushed fabric is unavailable for Fabric edge guide. The peeling sensor react to the brushed part, and not able to feed fabric properly.

## Limited media

With the following media, correction from the plotter is difficult.



When using any of the following media, perform test printing to determine whether it can be used or not.

- Hight stretch fabric (Stretch materials, vertically extendable knit,etc.)
- Materials which become largely extendable when getting wet by printing.
- Materials with large width variations.
- Materials which present partial wrinkles of slacks when being spread on a flat surface or materials which are totally curved.
- Materials with large take-up shift at the ends of media when rolled.
- Roll media with a paper tube whose strength is insufficient and which bends when attached to a feeding unit.

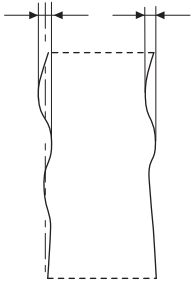

- Even when using media other than described above, be sure to print by optional test data. After checking the printing result, judge whether it can be used or not.

## Fabric conditions which enable to print

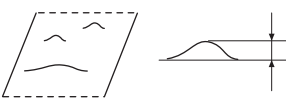
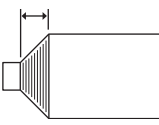
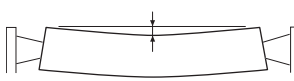
Items	Condition	Remarks
Width variation	less than $\pm 5\text{mm}$ / one side edge	 A vertical fabric strip is shown with a dashed rectangular outline. Two vertical double-headed arrows indicate the width at the top and bottom. The top width is slightly larger than the bottom width, illustrating width variation.
Curve when expanded	One-direction curve not allowed	 A dashed rectangular outline represents a fabric strip. A large black 'X' is drawn across the center, indicating that a one-direction curve is not allowed.
Slack height when expanded on a flat surface	2mm or less	 Two diagrams illustrate slack height. The left diagram shows a fabric strip with a wavy line representing slack. The right diagram shows a fabric strip with a flat surface and a vertical double-headed arrow indicating the slack height.
Displacement of roll edge	$\pm 15\text{mm}$ , Cloth (width of 500mm and less) is $\pm 2\text{mm}$ .	 A diagram of a roll of fabric. A vertical double-headed arrow indicates the displacement of the roll edge.
Inner diameter of roll	2 ~ 3 inches	
Fabric core strength	Roll bend of 5mm or less when set (with a fabric core thickness of 5mm or more)	 A diagram of a roll of fabric. A vertical double-headed arrow indicates the roll bend.
Length of fabric core exposure from fabric	20mm or more	
Fixation with fabric core	Tape at up to 3 points or weak adhesion	
Roll outer diameter	$\phi 420\text{mm}$ or less	
Roll weight	60kg or less	
Print side	Not specified	
Fabric wrinkle	Not allowed	



# Chapter 2

## Basic Operations



### This chapter

describes procedures and setting methods for ink and media preparation, and printing.

Workflow .....	2-2	When Using the Optional Heater	
Turning the Power ON/OFF .....	2-3	MTA-190 .....	2-26
Turning the Power ON .....	2-3	Notes for when using the heater .....	2-26
Turning the Power OFF .....	2-5	Turning the Power ON .....	2-27
Automatic function .....	2-6	Turning the Power OFF .....	2-27
Assistant functions .....	2-7	Adjust the angle of the optional heater	
Switching ON/OFF of Centering function ....	2-7	MTA-190 .....	2-28
Switching ON/OFF of Media detecting		Adjust the temperature of the heater .....	2-29
function .....	2-8	Test Feeding .....	2-30
Switching ON/OFF of Belt washing		Test Printing .....	2-31
function .....	2-9	Test Printing .....	2-32
Switching ON/OFF of Air blade .....	2-9	Head Cleaning .....	2-33
Switching ON/OFF of Belt heater .....	2-10	About head cleaning .....	2-33
Setting a Media .....	2-11	Perform head cleaning depending	
Maximum Print Area .....	2-11	on the test printing result .....	2-33
Notes for Setting a Media .....	2-11	Set the media feeding .....	2-34
Outline of media setting .....	2-12	Setting Feed Correction .....	2-34
About media route .....	2-12	Correct the ink drop position for bidirectional	
Attach the fabric winding roller .....	2-13	printing .....	2-36
Feed the media .....	2-15	Printing Data .....	2-38
Take up the media .....	2-21	Starting a Printing Operation .....	2-38
Setting the Head Gap .....	2-23	Stopping a printing operation halfway .....	2-39
Detecting the Media .....	2-24	Deleting Received Data (Data Clear) .....	2-39
Changing the printing origin .....	2-25		

**1** Turning the Power ON/OFF

Referring to “Turning the Power ON/OFF” (☞ P.2-3).

**2** Setting a Media

Referring to “Setting a Media” (☞ P.2-11).

**3** When Using the Optional Heater MTA-190

Referring to “When Using the Optional Heater MTA-190” (☞ P.2-26).

**4** Test Feeding

Referring to “Test Feeding” (☞ P.2-30).

**5** Test Printing

Referring to “Test Printing” (☞ P.2-31).

**6** Head Cleaning

Referring to “Head Cleaning” (☞ P.2-33).

**7** Set the media feeding

Referring to “Set the media feeding” (☞ P.2-34).

**8** Correct the ink drop position for bidirectional printing

Referring to “Correct the ink drop position for bidirectional printing” (☞ P.2-36).

**9** Printing Data

Referring to “Printing Data” (☞ P.2-38).

# Turning the Power ON/OFF

## Turning the Power ON

**Important!**

- Turn the power ON after the front cover and maintenance cover are closed.

**1**

### Turn on the power switch of the media feeding part.

- Set the power switch located on the back of machine to the “I” side.

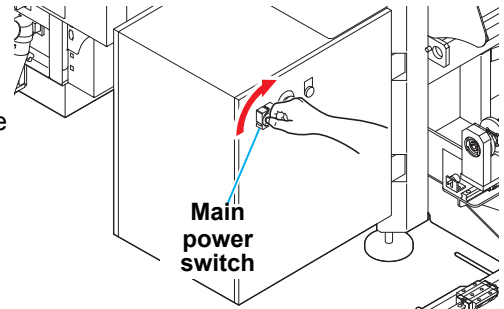

**2**

### Turn on the main power switch of the printer part.

- Set the main power switches located on the side of this machine to the “I” side.

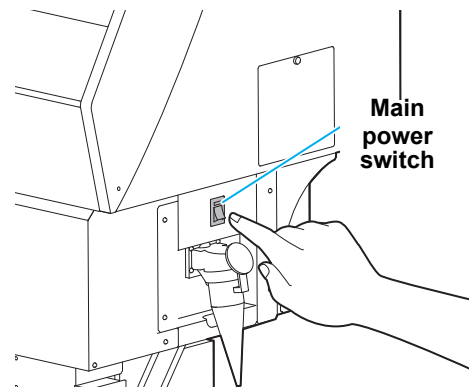

**3**

### Push the power button.

- Push the power button located on the operation panel.

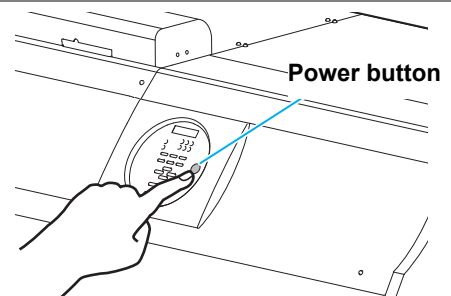

- The firmware version is displayed when the power is turned ON.
- The machine performs its initial operation.

Tx500B      Start-up  
Ver 1.00

**4**

### The machine enters LOCAL.

<LOCAL>

**5**

### Turn ON the power of the connected PC.



- In this machine, the power switches are independent each in the printer part and the media feeding part.
- Normally, keep the main power switch of the printer part turning on. If the main power switch of the printer part is left in the off-state, it may cause head nozzle clogging. There is a case which is difficult to recover by the symptom.

2

Basic Operations

Important!

- When the power is turned on, flushing or cleaning are carried out automatically, and then one minute of deaeration is performed before the next operation. While performing deaeration, "SEARCHING ORIGIN" flashes on the second line and the buzzer sounds at regular intervals.

PLEASE WAIT  
SEARCHING ORIGIN

## Turning the Power OFF

When having ended the operation of the machine, turn the power OFF by pressing the power button located on the front side. Check the following items when turning the power OFF.

- If the machine is receiving data from the PC or if there is any data that has not been output yet
- If the head has returned to the capping station
- If any error has occurred (☞ P.5-15 “Error messages”)

### 1 Turn OFF the power of the connected PC.

### 2 Turning off the power of the media feeding part.

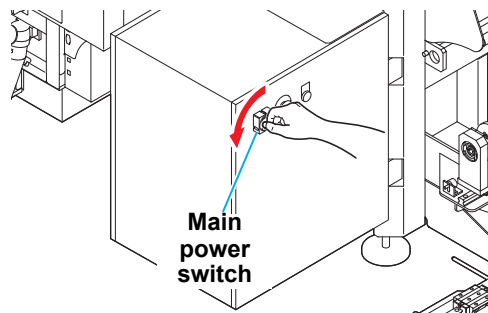

### 3 Turn off the power by pressing the power button of the printer part.

- The power supply button goes out.
- Do not turn OFF the main power switch located on the side of the machine.
- To use this machine again, light the green lamp by pressing the power button.

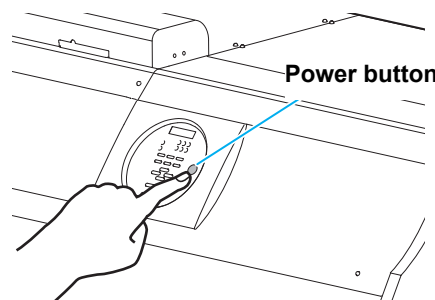

## Cautions when turning the power of the printer part off

### ● Do not turn the main power switch OFF.

When the main power switch is ON, the power periodically turns ON and the nozzle clogging prevention function (flushing function) and the pressure adjusting function operate.

When the main power switch has been turned OFF, the auto maintenance functions, such as flushing, do not operate, and this may cause nozzle clogging.

### ● Keep the front cover and the maintenance cover closed.

If the cover is opened, the auto maintenance function such as the flushing function does not work.

### ● Turn the power OFF after having checked the position of the head.

If the power is turned OFF in a state where the head has not returned to the capping station, the head dries, which may cause nozzle clogging.

In this case, turn the power ON again and check that the head has returned to the capping station, and then turn the power OFF.

### ● Do not turn the power OFF during printing.

The head may not return to the capping station.

### ● After having turned the power button OFF, turn the main power switch OFF.

When turning the main power switch off for moving the machine or for solving the error or the like, press the power button on the front of the machine, check the display is turned off on the operation panel, and then turn the main power switch off.

# Automatic function

The media position is adjusted automatically since the feeding unit equips the centering function.



- Do not touch this machine during the automatic function. There is the danger of injury as the pressure roller may move down automatically etc. and your finger may be pinched.

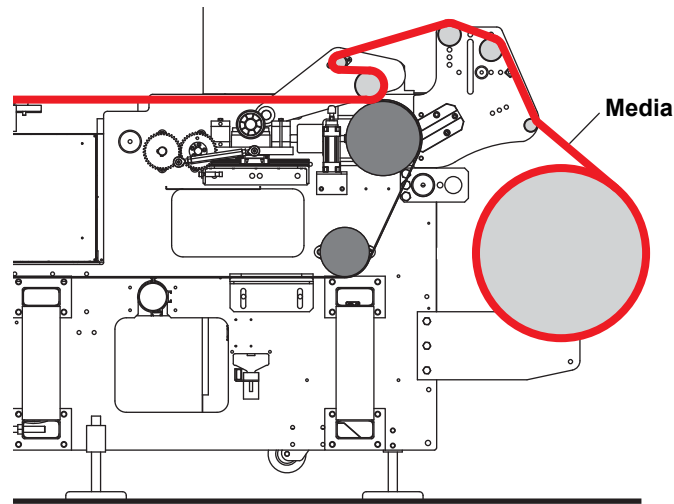

Until the media is detected in the peeling sensor (START) located right behind the peeling roller, the take-up unit is in the idling status. When it is detected, the take-up unit takes up the media until the peeling sensor (STOP) responds.

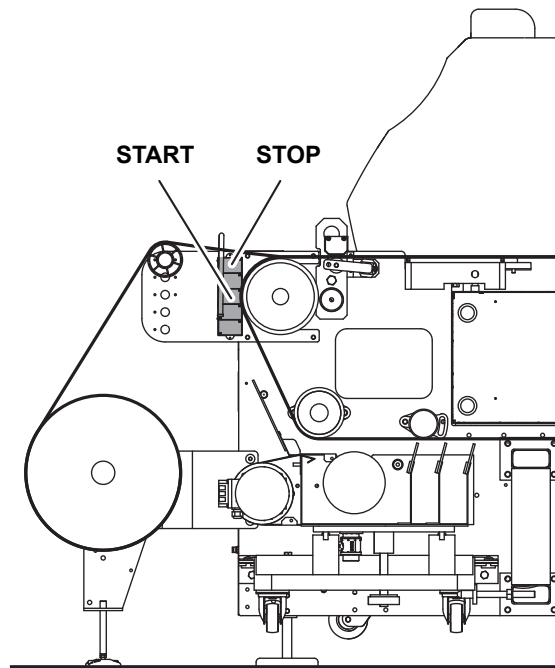

# Assistant functions

The assistant functions which are prepared in this machine, such as the centering, the belt heater, the belt washing, the media heater, etc., also includes the function which is able to switch between ON/OFF depending on the type of media.

## Switching ON/OFF of Centering function

By using the centering function, the media can be kept in straight during printing. However, depending on the winding condition of media, the media might overlap due to the centering operation.

1

Switch by pressing [ON]/[OFF] of “CENTERING UNIT” on the operation touch panel.

- If you wish to change to ON : Switch to [ON] by pressing [OFF].  
(The green lights up.)

- If you wish to change to OFF : Switch to [OFF] by pressing [ON].  
(The orange lights up.)

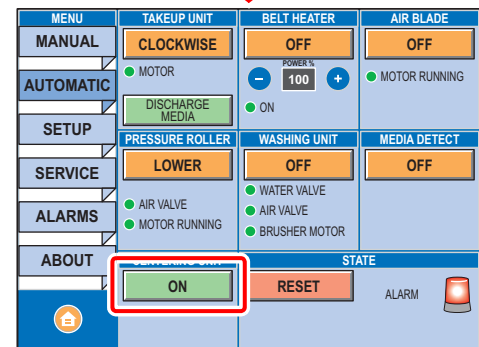
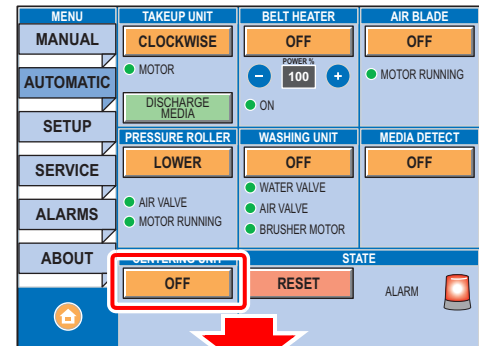

2

Basic Operations

## Switching ON/OFF of Media detecting function

If the media detecting function is turned to “ON”, the printing operation is automatically stopped when the media end is detected by the media end sensor.

**1**

Switch by pressing [ON]/[OFF] of “MEDIA DETECT” on the operation touch panel.

- If you wish to change to ON : Switch to [ON] by pressing [OFF].  
(The green lights up.)

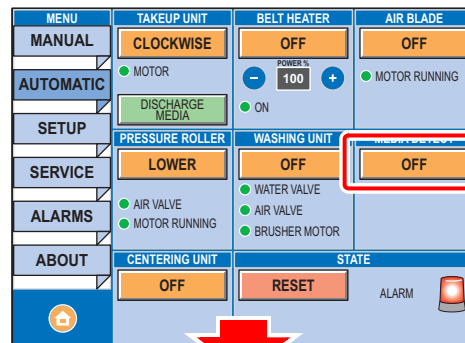

- If you wish to change to OFF : Switch to [OFF] by pressing [ON].  
(The orange lights up.)

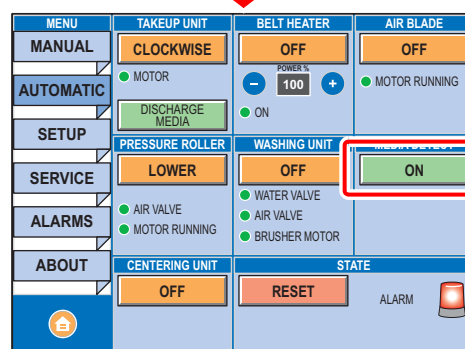



## Switching ON/OFF of Belt washing function

By using the belt washing, you can wipe off ink stuck through and on the feeding belt.

### 1 Switch by pressing [ON]/[OFF] of “WASHING UNIT” on the operation touch panel.

- If you wish to change to **ON** : Switch to [ON] by pressing [OFF].  
(The green lights up.)

**Important!**

- The belt washing unit is ON only when the feeding belt is in the operation status. Even if it is ON on the operation touch panel, if the feeding belt is not in the operation status, it will not operate.

- If you wish to change to **OFF** : Switch to [OFF] by pressing [ON].  
(The orange lights up.)



- In case of the “AUTOMATIC” screen, the washing unit is automatically turned on.

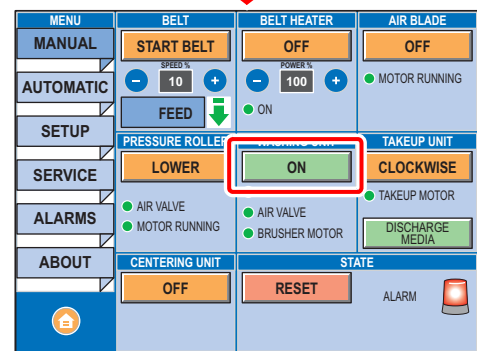
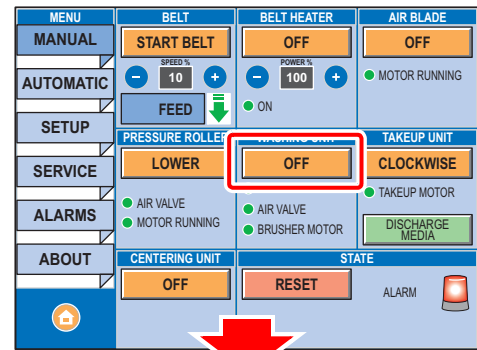

## Switching ON/OFF of Air blade

By using the air blade, water droplets on the carrying belt, which are due to the belt washing, can be more powerfully eliminated.

### 1 Switch by pressing [ON]/[OFF] of “AIR BLADE” on the operation touch panel.

- If you wish to change to **ON** : Switch to [ON] by pressing [OFF].  
(The green lights up.)

- If you wish to change to **OFF** : Switch to [OFF] by pressing [ON].  
(The orange lights up.)

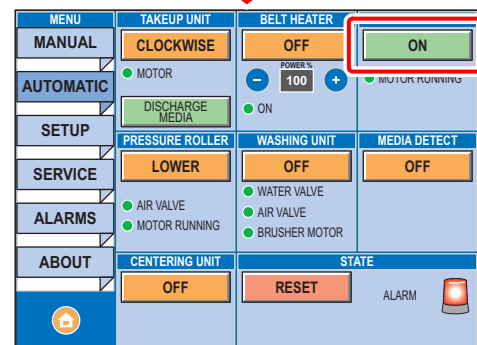
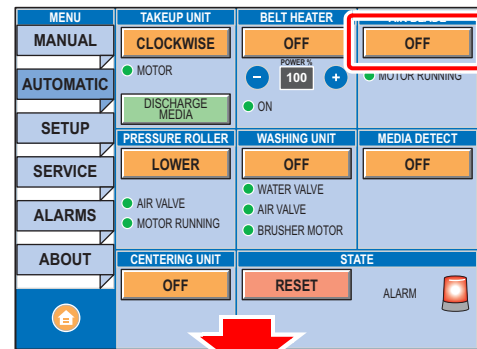

## Switching ON/OFF of Belt heater

By using the belt heater, you can keep the adherence and dryness of the feeding belt.

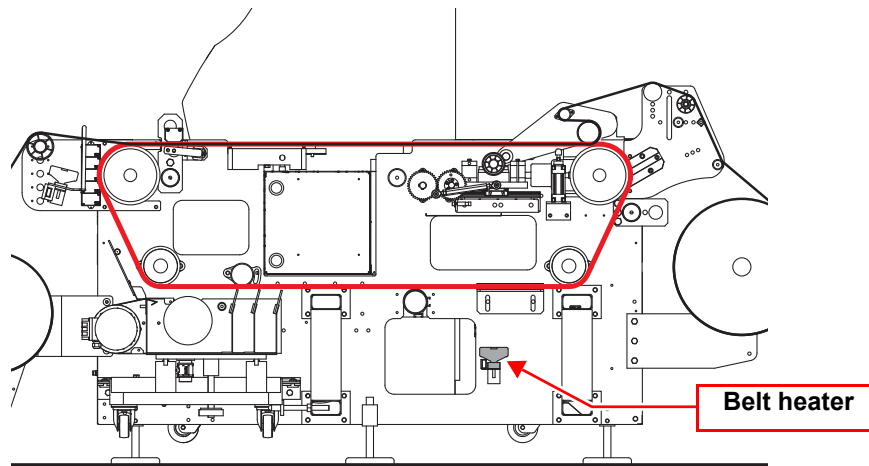

# 1

Switch by pressing [ON]/[OFF] of “BELT HEATER” on the operation touch panel.

- If you wish to change to ON : Switch to [ON] by pressing [OFF].  
(The green lights up.)

**Important!**

- When recoating adhesive, be sure to turn this OFF.

- If you wish to change to OFF : Switch to [OFF] by pressing [ON].  
(The orange lights up.)

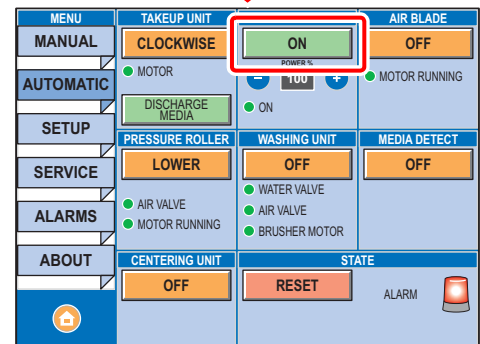
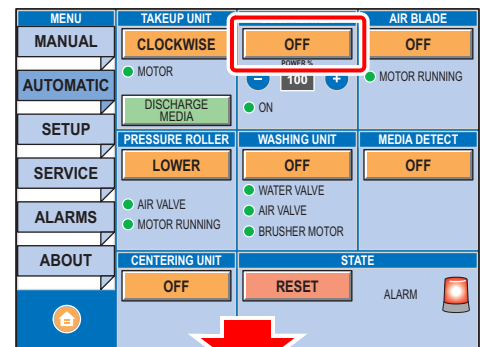

# 2

Set by pressing [+] / [-] of “BELT HEATER” of the operation touch panel.

- When increasing the temperature : Push [+].
- When decreasing the temperature: Push [-].

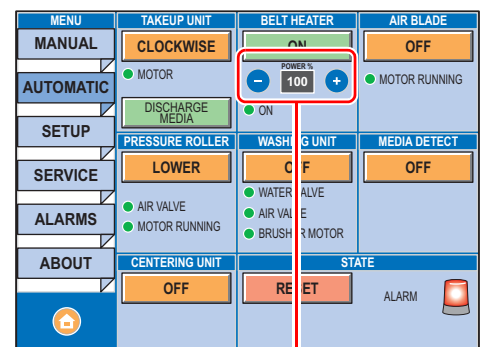

Press [+] / [-].

# Setting a Media

## Maximum Print Area

The white area shown in the following figure represents the maximum print area.  
The area other than that is the dead space that cannot be printed.

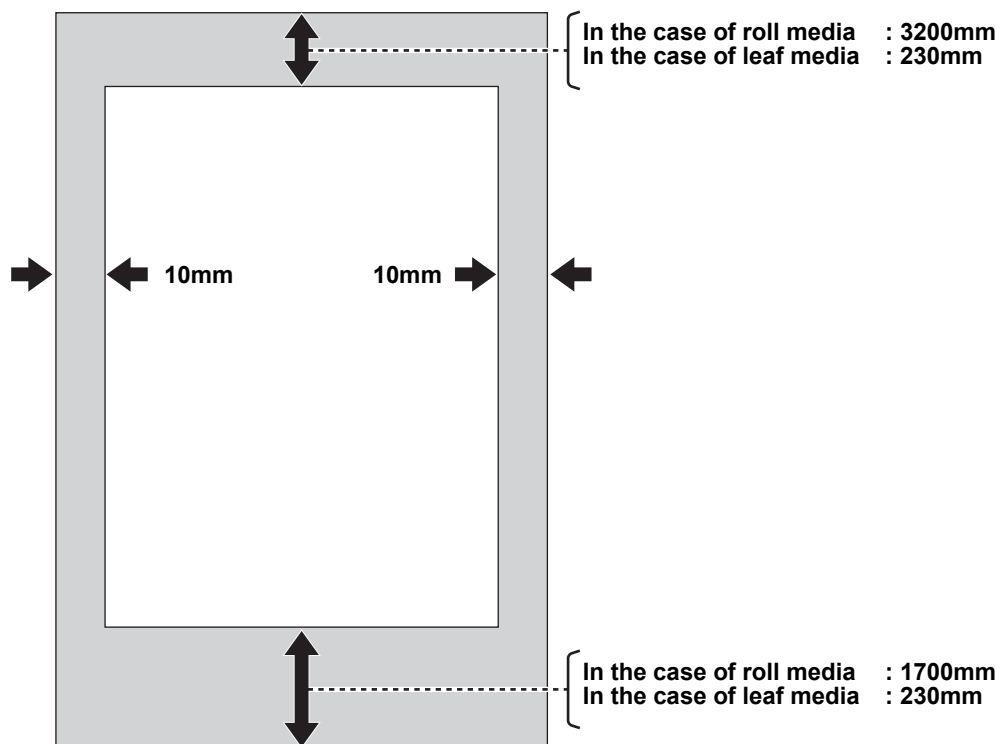

- The margin at the front and rear edges of the fabric can be reduced using a guiding fabric.

For usable media, refer to P.1-23 “Usable Sizes of Media”.

## Notes for Setting a Media



- The roll shaft for setting the roll media is heavy, weighing 8 to 10 kg only with the shaft itself. When setting, take care not to drop the media or the roll shaft on your foot, etc. It could cause injury due to its heavy weight.
- This operation should be performed by 2 or more person because the roll is heavy in weight.

## Outline of media setting

It is recommended to set media by two persons and more from the aspect of workability.



- As the pressure roller is very heavy, much care should be taken for falling of the roller and being wedged during media setting.

**Attach the fabric winding roller**  
(👉 P.2-13)

To prevent the media from being stained, prepare the fabric winding roller.

**Feed the media**(👉 P.2-15)

Set the media and feed it to the take-up unit side.

**Take up the media**(👉 P.2-21)

Fix the media on the paper core and take up it.

**Setting the Head Gap**  
(👉 P.2-23)

Refer to P.2-23 "Setting the Head Gap".

**Detecting the media** (👉 P.2-24)

Refer to P.2-24 "Detecting the Media".

## About media route

The route for setting the fabric media is as shown in the following diagram. Prior to setting the media, if you understand the routing of the media, you can perform the setting of the media smoothly.

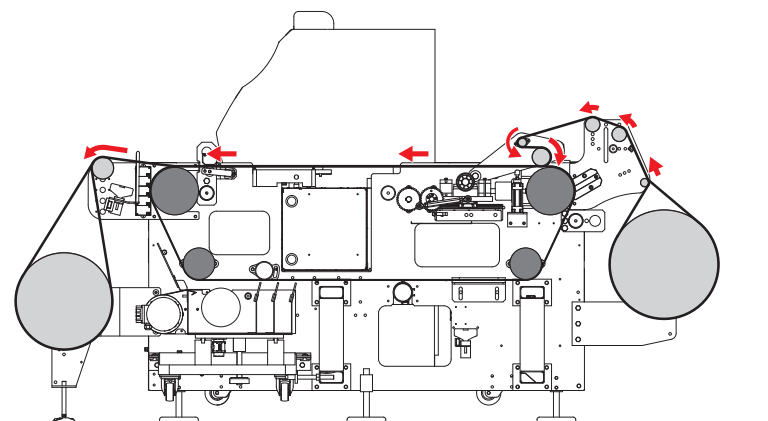

## Attach the fabric winding roller

After washing belt, drops of water that could not be removed with the wiper of the washing unit may remain in some cases.

If those drops are carried to the belt surface, it may stain the media before printing.

You can remove drops adhering to the belt by attaching the fabric winding roller in advance.

**Important!**

- Before shipment, the fabric winding roller had no fabric. Prepare water-absorbing fabric with the size below:

**Material** : cotton sheeting, velveteen, etc. (water-absorbing fabric)

**Size** : 195cm x 100cm

# 1

### Remove the fabric winding roller.

- The fabric winding roller is located in the rear surface of this machine and around the feeding belt roller.



# 2

### Wind the fabric on the fabric winding roller.

- (1) Align the roller with the fabric as indicated in the right figure.

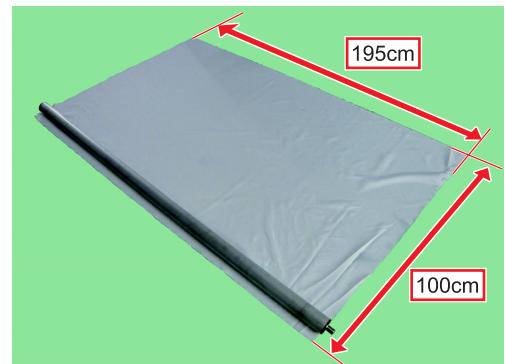

- (2) Fix the roller and the fabric with adhesive tape.



- (3) Wind the fabric on the roller and fix it with adhesive tape.



# 2

Basic Operations

---

**3****Attach the fabric winding roller with the fabric.**

- Attach the fabric winding roller by aligning it with the groove of the resin block around the feeding belt roller on the rear surface of this machine.

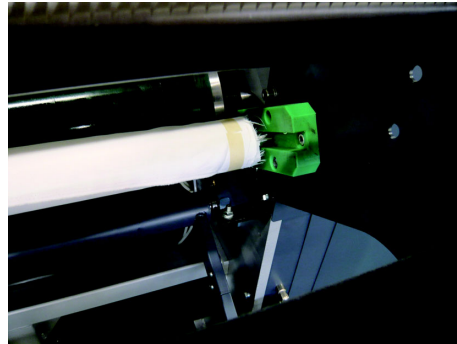
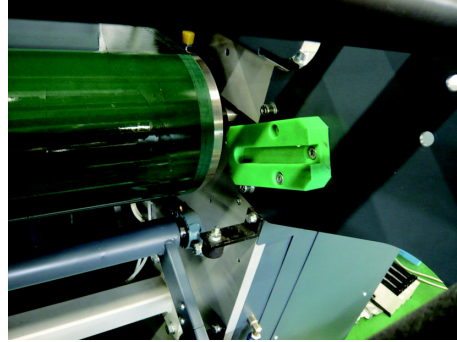
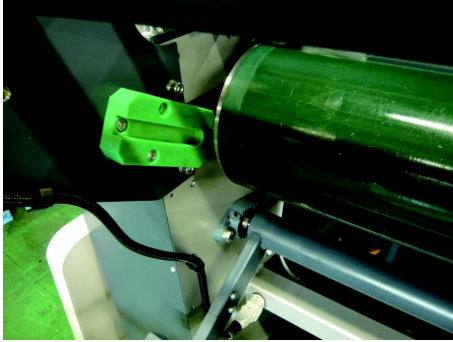

---

**4****Rotate the feeding belt to check that the fabric winding roller can rotate smoothly.**

# Feed the media

**1** Set it to the “MANUAL” screen by pressing [MANUAL] on the operation touch panel.

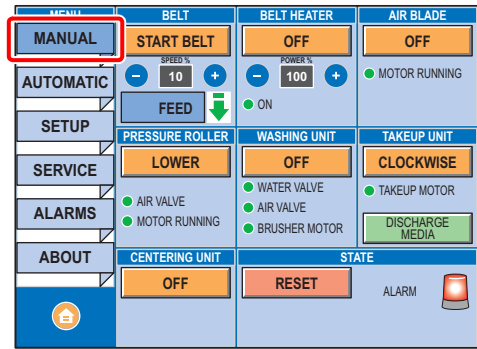

**2** Adjust the position of the feeding unit by rotating the [MANUAL CENTERING] lever located on the rear surface control panel so that the unit is positioned at the center almost of the centering range.

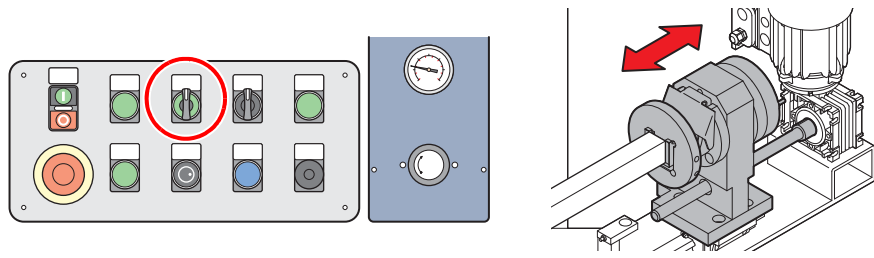

**3** Set the media on the roll shaft.

(1) Rotate the roll shaft and make the roll shaft slot turn up.

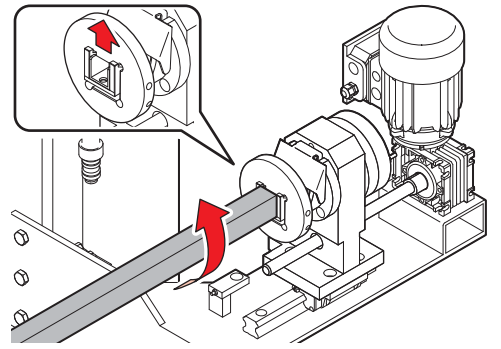

(2) Tilt the shaft fixing.



• Before moving the shaft fixing, be sure to check that the roll shaft slot turns up. If you move the shaft fixing with the roll shaft slot turn down, the roll shaft may fall off and it is very dangerous.

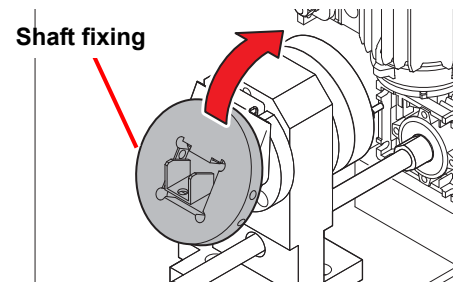

(3) Remove the roll shaft.

- (4) Put the media through the roll shaft and fix with the roll holder.
- After setting the roll holder, rotate the media manually to check that the media does not slip between the roll holder and the paper core.
  - If slip must occur during printing, fix the roll holder and the paper core with tape.

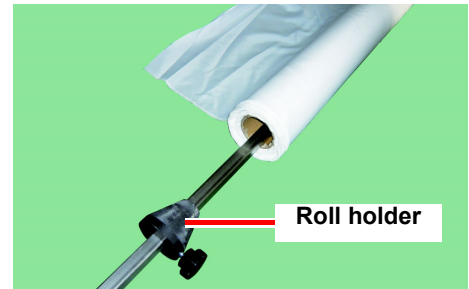

- (5) Set the roll shaft on the feeding unit.
- (6) Return the shaft fixing to the original position.

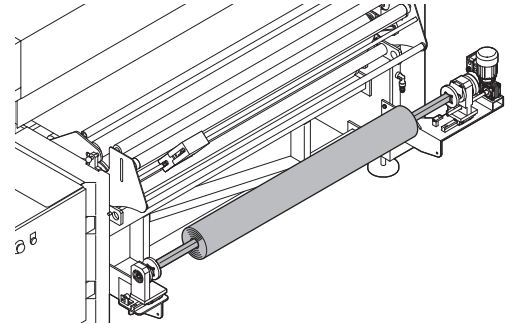

- Surely fix the shaft fixing. If you rotate the media without fixing it, the roll shaft may fall off and it is very dangerous.

## 4 Draw out the media by hand.

- Draw out the media approx 2m.

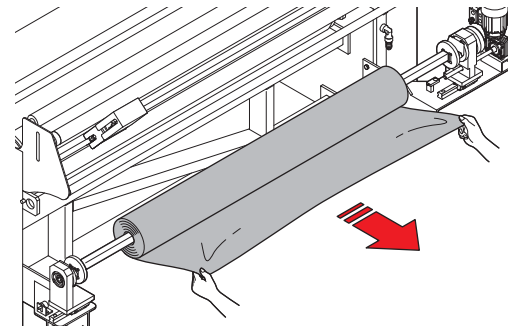

## 5 Pass the media through the centering unit sensor.

- For the media of 1000mm and less in width, the media may exceed the adjustment range of the right and left movement of the centering sensor unit when you set the media on the center basis. In this case, adjust the setting position of the media so that it may fall inside adjustment range of the centering sensor.

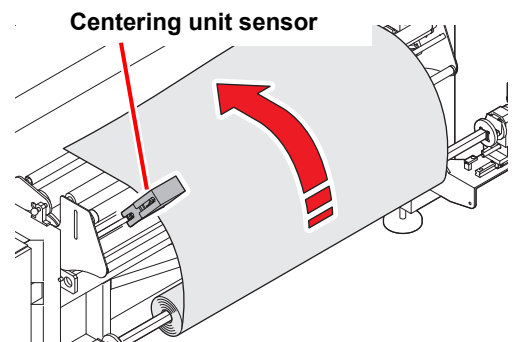

## 6 Push the safety pins on both ends of the pressure roller.

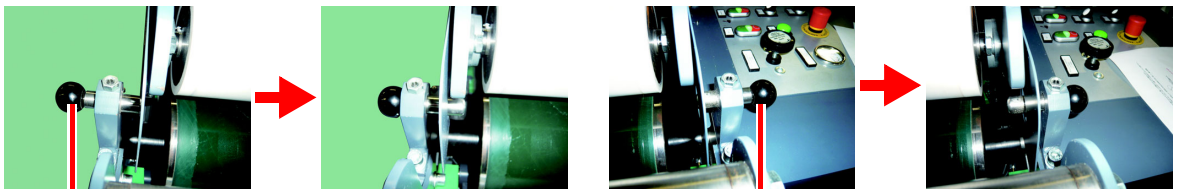

Safety pin

Safety pin



- To avoid the pressure roller from unexpectedly falling and causing injuries, make sure to insert the safety pins securely.
- Make sure that the tips of the safety pins are completely out; otherwise, this will not prevent the pressure roller from falling.



**7** After passing the media to the turn-back bar of the upper side of the pressure roller, wind the media around the turn-back bar roller.

**Important!**

- Smoothing wrinkle roller can function when the media is set at the center basis.
- Smoothing wrinkle roller cannot function when the media is set at the right end basis. In this case, do not use the smoothing wrinkle roller.

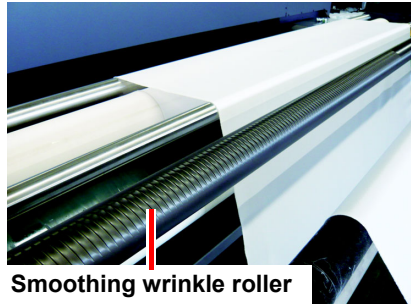

Turn-back bar roller

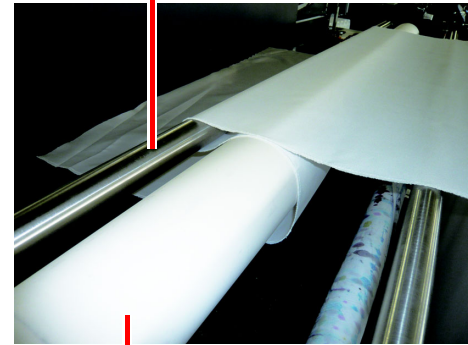

pressure roller

**8** Check that the media is not set slanted from the media roll ends, the centering sensor, and the pressure roller.

**Important!**

- When you wish to set the media of maximum width (1860mm), set it on the position where it does not conflict with the belt encoder. If the media may be caught in the belt encoder, normal printing cannot be performed.
- If the media is set slanted, adjust the slanted part by moving the media right and left.
- If you set the media of maximum width (1860mm), be careful about it including conflict with the belt encoder. Even if you move the media, misalignment cannot be corrected in some cases. Therefore, perform adjustment of the centering position etc. to prevent the media from slanted setting.

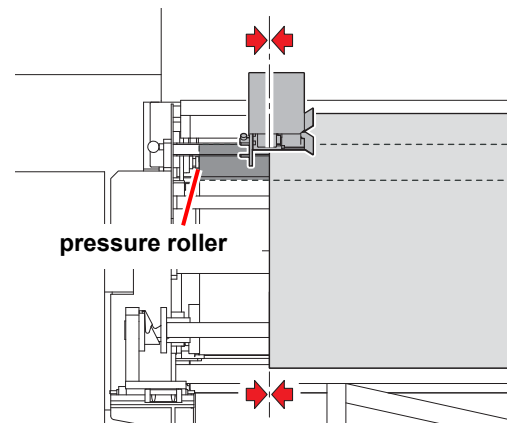

See from the rear side of the machine and check that the media is set straight.

**9** Return the safety pins to the original position.

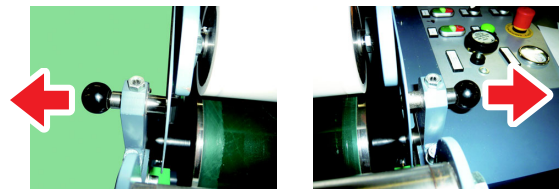

# 10

Lower the pressure roller by turning the [PRESSURE ROLLER] lever to the “DOWN” side.

- Rotate the adjusting dial to adjust the pressure of the pressure roller (refer to the table below).
- Check the air pressure gauge located over the control and adjust the pressure depending on the media to be used.
- Depending on the kind of the media to be used, pre-treatment and adhesive status, pressure adjustment is required in some cases. For reference, for stretch material, make the pressure lighter, and for non-stretch material, make the pressure stronger.
- After printing starts, also check the peeling status of the fabric on the take-up side of this machine to fine adjust the pressure.

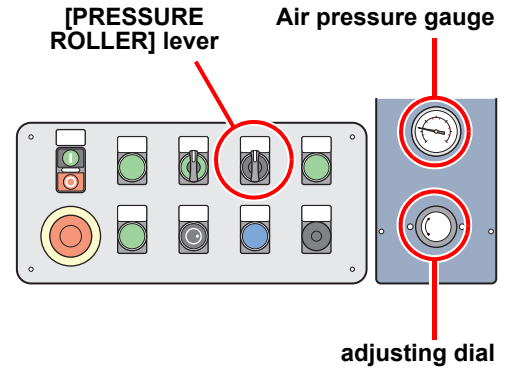

Rotating direction of adjusting dial	pressure roller	Air pressure gauge display
Rotate clockwise	Lighten	Air pressure goes up.
Rotate counterclockwise	Gets heavier	Air pressure goes down.



- The pressure roller is a heavy roller.
- Before you move the pressure roller down, check that no one is near it.
- It is very dangerous if your hand etc. is wedged by the pressure roller as there is the danger of injury.

# 11

If needed, adjust the [CLUTCH TUNING] dial.

- Adjusting the rotating friction of the feeding media by turning the adjusting dial. (Refer to the table below).
- Increase the friction if there is the slack on the feeding media.
- Decrease the friction if there is a longitudinal wrinkle on the feeding media.

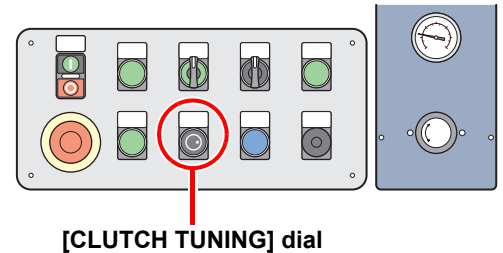

Adjusting dial	Rotating friction
Rotate clockwise	Gets heavier
Rotate counterclockwise	Lighten

## 12 Adjust the position of the centering sensor.

- Rotate the centering sensor unit to adjust the centering detection width.
  - Maximum** : Allows media misalignment of about 30mm.
  - Minimum** : Allows media misalignment of about 10mm.
- Use it by adjusting the position between the maximum value and the minimum value at will.

- Important!**
- For the media with much weaving, the stretch material or the like, the effect of centering may not be expected. Be sure to perform the test printing to check if the centering function works effectively before using.
  - If media windles or wrinkle occurs at fixation, print with the centering function OFF.

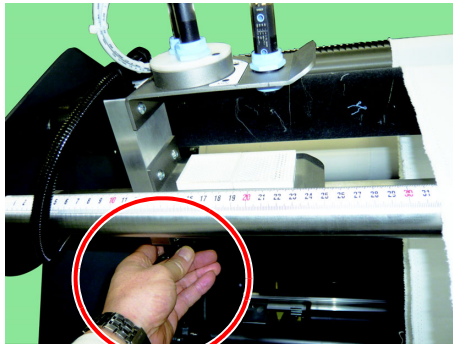

Loosen the finger screw located on the rear surface of the sensor unit to make the sensor unit movable to right and left.

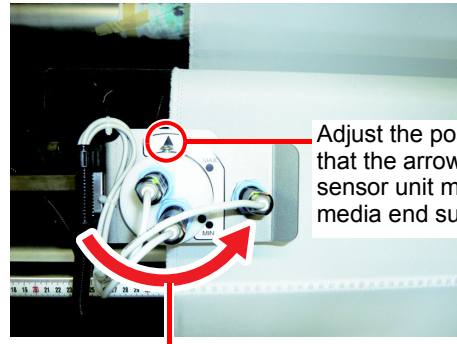

Adjust the detection width of the centering sensor.

Adjust the position so that the arrow of the sensor unit matches the media end surface.

## 13 Switch the centering function to “ON” by pressing [OFF] of “CENTERING UNIT” on the operation touch panel.

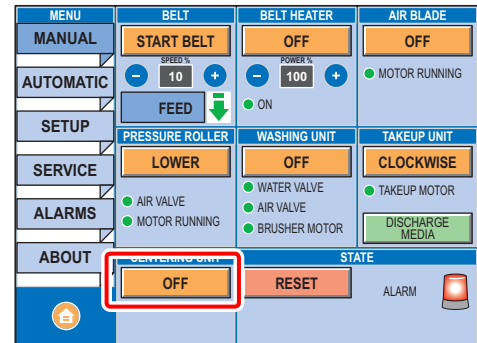

## 14 If needed, switch to [ON] by pressing [OFF] of “WASHING UNIT”.

- If needed, switch to [ON] also for “AIR BLADE” and “BELT HEATER”.

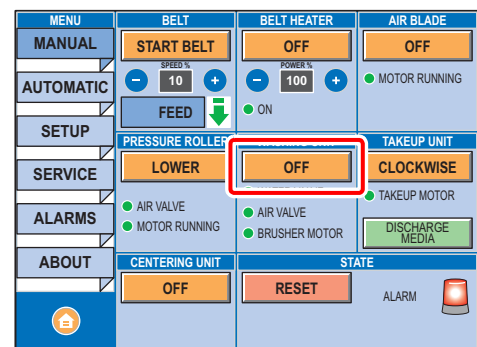

# 15

Set the speed to about 10m/min by pressing the BELT SPEED [-]/[+].

- Set the belt operating direction to [FEED].

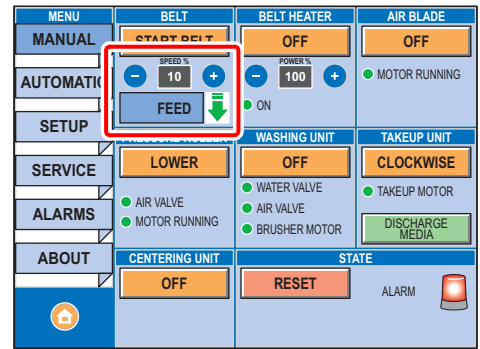

# 16

Operate the belt by pressing [START BELT] of "BELT", and carry the media.

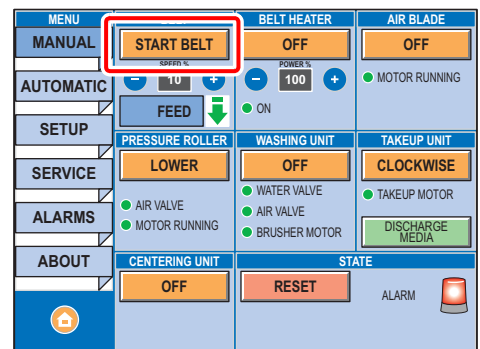

**Important!**

- With the jog key of the printer unit, you can perform back feed of the media in units of 300mm. However, do not perform back feed if possible as there is danger of wrinkle and fold occurring on the media, media stain due to belt washing water, etc.
- If you wish to perform back feed by necessity, first loosen the media of take-up side, operate keys while taking up the media of the feeding side, etc., and then perform it with much care about the media status.
- For damages such as break of printer or media, deterioration of printing quality, etc. caused from performing back feed, our company shall not hold responsible. So please be careful about it.

# 17

Stop the belt by pressing [STOP BELT] of "BELT".

- Stop the belt, if a sufficient amount of media fastening the media on the paper pipe of the winding unit is fed out.

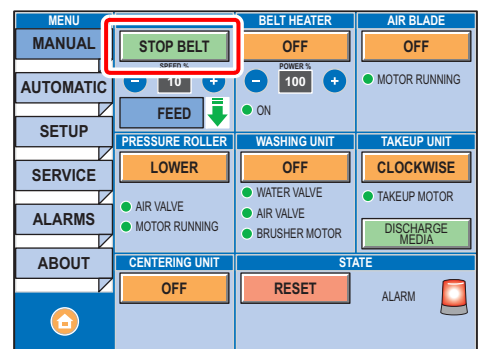

## Take up the media

Take up the fed media on the empty paper core.

### 1 Set the empty paper core on the take-up unit.

- Set the empty paper core on the take-up unit in the same way as the setting of the roll shaft of the feeding unit.
- The empty paper core with radial thickness of 5mm and more is recommended.
- If radial thickness of the paper core is not enough, take-up may not be performed properly because the paper core may be broken or bent in the middle of take-up.

### 2 Fix the media on the empty paper core.

- Feed the media until it conflicts with the empty paper core and fix it on the paper core with adhesive tape.

- Important!**
- When you fix the media on the empty paper core, fix it at intervals of 30cm and more preferably in order not to be peeled at take-up.

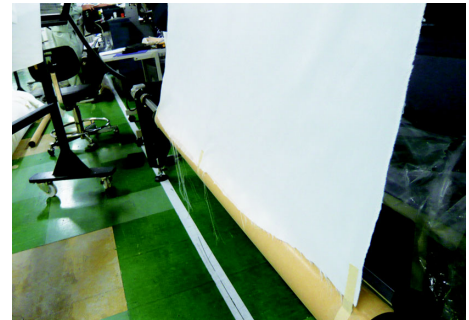

### 3 Wind the media by operating the [TAKE-UP MANUAL] lever on the front control panel.

- Wind the media making going round at least twice to prevent the media from falling from the paper core.

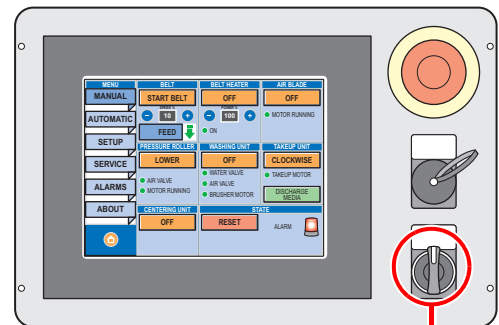

[TAKE-UP MANUAL] lever

4

Set it to the “AUTOMATIC” screen by pressing [AUTOMATIC] on the operation touch panel.

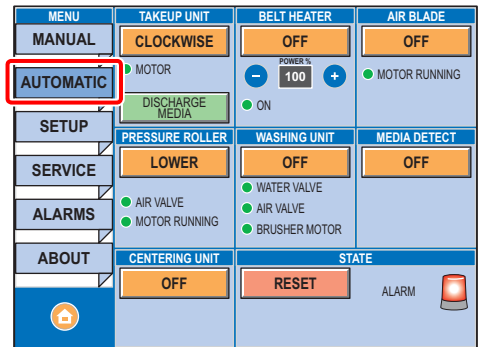

5

Switch by pressing [CLOCKWISE] of “TAKEUP UNIT” on the operation touch panel, according to the winding direction of media. (Refer to the table below.)

Winding direction	Rotation direction
Outside-winding	CW
Inside-winding	CCW

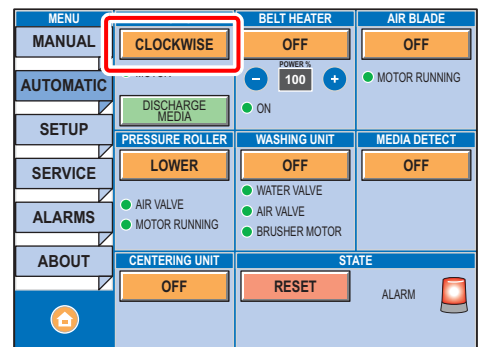

6

Switch the centering function to “ON” by pressing [OFF] of “CENTERING UNIT” on the operation touch panel.

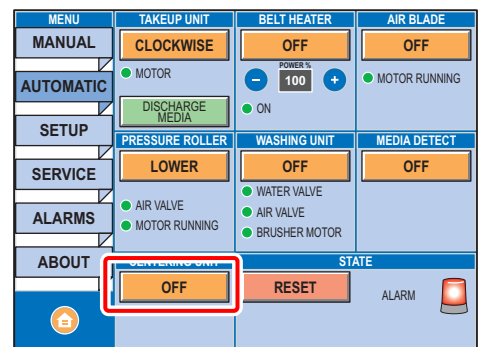

7

If needed, switch to [ON] by pressing [OFF] of “WASHING UNIT”.

- If needed, switch to [ON] also for “AIR BLADE” and “BELT HEATER”.

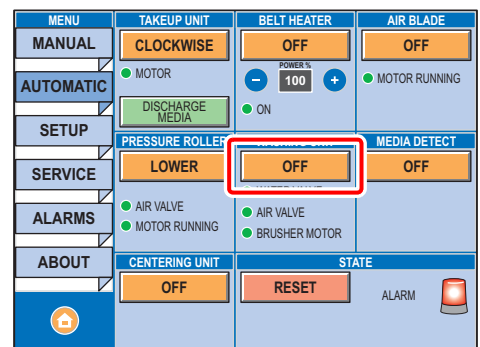

## Setting the Head Gap

Set the head gap (height from the media to the nozzle plane of the heads).

When the head is moved to the upper of belt at the printing or by the maintenance function or so, it moves to the head gap position which has been set.

The upper limit of the head gap varies with media thickness.

Available setting values: [1.5 mm to 7.0 mm] (in units of 0.1 mm / Default : 2.0 mm)

**Important!**

- It is recommended to use the equipment keeping the head height 3mm or more. When using the equipment with the head height of 3mm or less, the blurring of the printed images, changes in color while printing or nozzle missing due to ink mist could be caused.
- Please be aware that we shall not be held ourselves responsible for the printing quality caused by the use of this equipment with the head height of 3 mm or above.

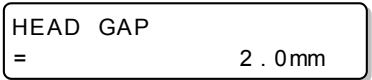
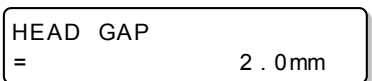
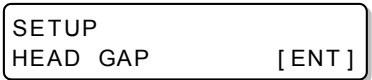
- 1 Press the **MEDIA** key in LOCAL. 
- 2 Press the **ENTER** key. 
- 3 Press **▲ ▼** to set a value of the head gap.  
• Set value : 1.5 to 7.0mm 
- 4 Press the **ENTER** key. 
- 5 Press the **END** key several times to end the setting.



### How to check the value of the head gap

When you check the head gap value currently set, perform the following procedures:

- Press the **ENTER** key in Local. 
- Press the **ENTER** key several times to display [HEAD GAP].  
• The head gap value currently set is displayed.

### Setting the head gap without **MEDIA** key

You can set the head gap by using the **FUNCTION** key in the Local without pressing the **MEDIA** key.

- Press the **FUNCTION** key in Local. 
- Press **▲ ▼** to select [SETUP], and press the **ENTER** key. 
- Press **▲ ▼** to select [HEAD GAP], and press the **ENTER** key.  
• The screen in the Step 2 is displayed. Perform the procedures from the Step 3.

## Detecting the Media

Media detection is a function for setting the printable area.

# 1

Press   on the media selection screen, and select **ROLL/LEAF**.

- If "LEAF" is selected, go to the step 2.



MEDIA SET  
ROLL < > LEAF

# 2

Input width of the printing area.

- Set the printing area in the Y direction.

**If you know the printing width:**



- (1) Press   to input the value.
- (2) Press the  key.
  - The carriage moves.

PRINT AREA  
Width = 1860mm

**Important!**

- When inputting the printing width with  , be careful that it may print out of the media depending on the print start position set on the Step 3.



**If you do not know the printing width:**

- (1) Press the   key to select "MANUAL".
- (2) Press the  key.
  - The carriage moves.

PRINT AREA  
Width = MANUAL

# 3

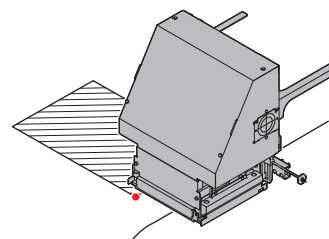

Set the printing origin.

- (1) Press   to move the carriage to the print start position (origin).
  - Put an arrow mark of the carriage on the setting position.
- (2) Press the  key.
  - If "MANUAL" is set on the Step 2, go to the Step 4.
  - If a number is entered for the printing width on the Step 2, the left end of the printing area is automatically adjusted to the entered number, and the mode is returned to the LOCAL. Skip the step 4.





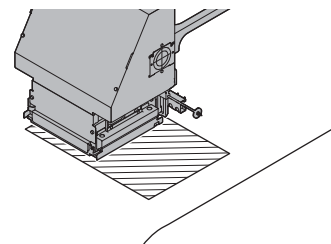

# 4

Set the width of the printing area.

- (1) Press   to move the carriage to the left end of the printing area.
  - Put an arrow mark of the carriage on the setting position.
- (2) Press the  key.
  - After capping, the screen returns to LOCAL.



- If you set the wrong printing area, detect again from the Step 1 after performing the operation below.

- (1) Press the  key.
- (2) Press   to select [MEDIA RESET].
- (3) Press the  key.
- (4) Press the  key.



## About entering media thickness and remaining amount

When you set “Media remaining amount display” and “Media detection” to “ON” and “MANUAL”, input screen for the media thickness and the remaining amount is displayed after detecting the media width.

- 1** Display the screen for entering media remaining amount.

```
Input of MediaLength
=          **.*m
```

- 2** Press   to enter the media remaining amount.

```
Input of MediaLength
=          **.*m
```

- 3** Press the  key.





## Changing the printing origin

The position of the printing origin can be changed.

- 1** In Local, Press    .
- It enters into the origin setting mode.

```
ORIGIN SETUP
0.0      ----
```

- 2** Press     to set the origin to a desired position.

- Select the carriage and media, moving the point with    .
- When you press the  key here, you can perform media cutting.

```
ORIGIN SETUP
0.0      0.0
|         |
Origin   Origin
(Length) (Width)
```

- 3** After determining the origin, press the  key.
- The printing origin is changed.

```
ORIGIN SETUP
** ORIGIN **
```

# When Using the Optional Heater MTA-190

The optional heater MTA-190 operates together with the Tx500-1800B, automatically turning on and off when the printer prints.



- Because the optional heater MTA-190 is a device that assists in drying, there may be times when drying is incomplete. If the ink doesn't dry and penetrates to the back or causes stains, use an interleaf to prevent penetration.
- When using the heater, the sheet metal around the part on which heat has been irradiated becomes hot. Especially, the part below generates heat. Be careful about it. Do not touch the part after using the heater.

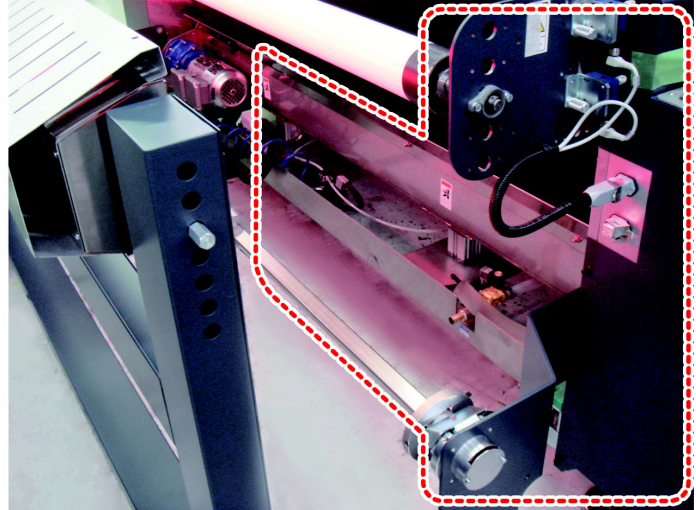
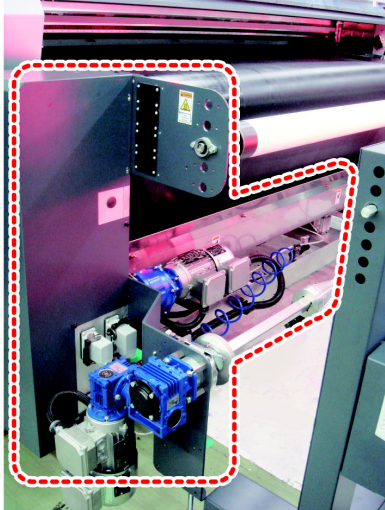

## Notes for when using the heater

Lock the casters before use.

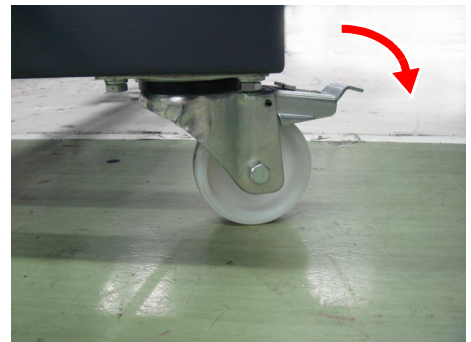

We recommend putting 400 mm or more between the optional heater MTA-190 and the media.  
There is about 350 mm where the heater base touches the take-up device.

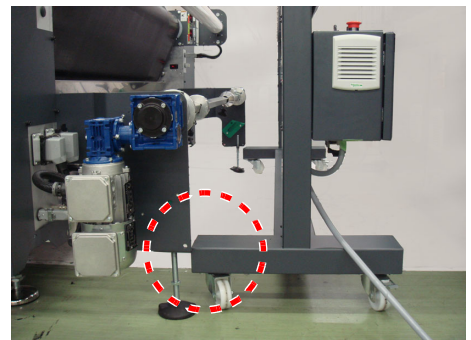

## Turning the Power ON

1

### Turn the main power switch ON.

- Set the power switches located on the back of this machine to the "ON" side.

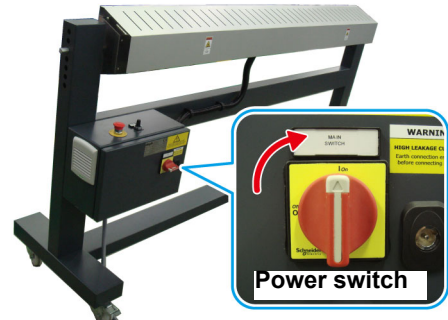

## Turning the Power OFF

When having ended the operation of the machine, turn the power OFF by rotating the power switch located on the back side.

1

### Rotate the power switch to turn the power OFF.

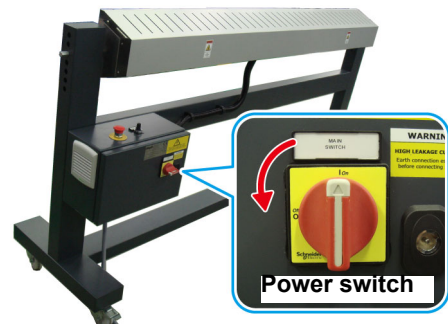

2

Basic Operations

## Adjust the angle of the optional heater MTA-190

When using the optional heater MTA-190, adjust the angle of the heater depending on the media angle to dehydrate the media normally after printing.

**Important!**

- When using the optional heater MTA-190, make it parallel against the media surface from the free roller to the take-up device.
- The angle of the media surface differs depending on the take-up method (inward/outward) or the taken-up amount of the media.

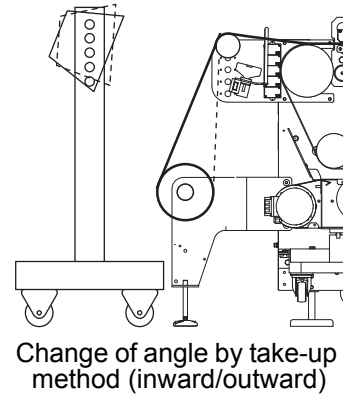
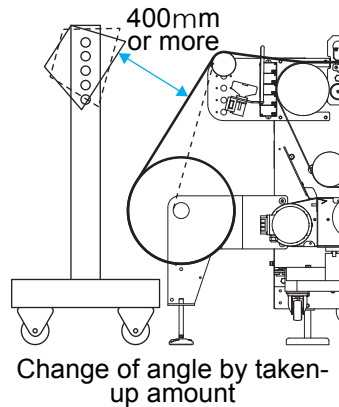

- If the heater is too close to the media, it will not only damage the media but may also cause burns. Put about 400 mm of distance between the heater and the media.

**1**

Loosen the hexagon head bolt on the side surface of the optional heater MTA-190 using the monkey wrench attached to TX500-1800B .

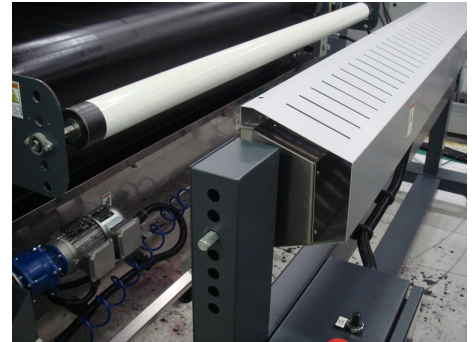

**2**

Adjust the angle of the heater and tighten the hexagon head bolt.

**Important!**

- Adjust the angle of the heater with two persons or more without fail.

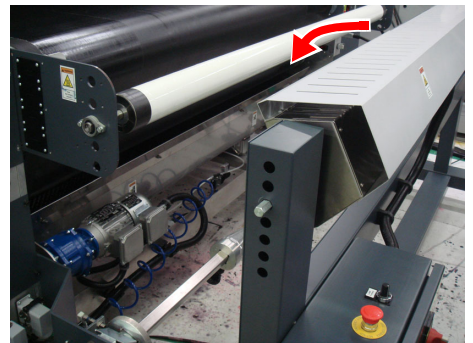

## Adjust the temperature of the heater

Turn the volume knob to adjust the heater temperature.

We recommend using the heater with 400 mm of distance and at 40% volume (for cotton).

Depending on the media or the pre-treatment agent, it may change color due to high temperature. If discoloration occurs, either lower the heater output, or increase the distance between the heater and the Tx500-1800B.

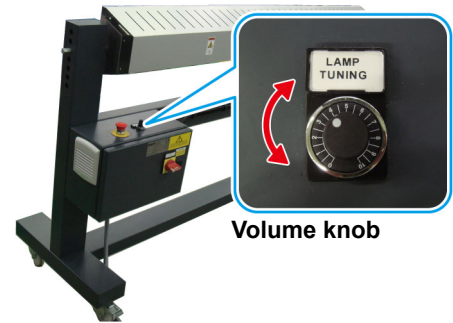

If printing data with a high coverage rate, the ink may not dry, penetrating to the back. If penetration to the back occurs, reset the drying time (☞ P.3-4 “Setting Drying Time”) or use an interleaf to prevent penetration.





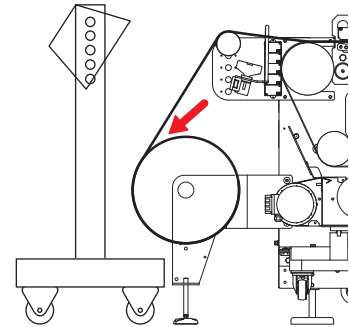



- In case you check color penetration to the back  
Please check whether color penetration to the back occurs or not (the drying characteristics) by checking whether ink is attached on paper by inserting paper (such as copy paper) in the arrow in the right picture during print.  
In case ink is attached to the paper, color penetration to the back may occur. In this case, reconfirm the heater conditions in use. Or, set the drying time.



# Test Feeding

Perform this function before printing, and check whether the media can be fed normally.

- 
- |          |  |                    |
|----------|--|--------------------|
| <b>1</b> | <b>Press the  key in LOCAL three times.</b> | TEST FEED<br>[ENT] |
|----------|--|--------------------|
- 
- |          |   |                          |
|----------|---|--------------------------|
| <b>2</b> | <b>Press the  key.</b> | TEST FEED<br>START [ENT] |
|----------|---|--------------------------|
- 
- |          |  |                                  |
|----------|--|----------------------------------|
| <b>3</b> | <b>Press the  key.</b><br>• Start test feeding. | ** TEST FEED **<br>PLEASE : WAIT |
|----------|--|----------------------------------|
- 
- |          |  |  |
|----------|--|--|
| <b>4</b> | <b>Press the  key.</b><br>• The feeding operation is continued until you press the  key.<br>• Feed it to some extent and check the feeding status, and then press the  key to terminate. |  |
|----------|--|--|
-

# Test Printing

Print a test pattern to check that there are no discharging defects such as nozzle clogging (slight touching of ink or nozzle missing).

## Relationship between head row and test pattern

The relations between head row and test pattern print position are as follow.

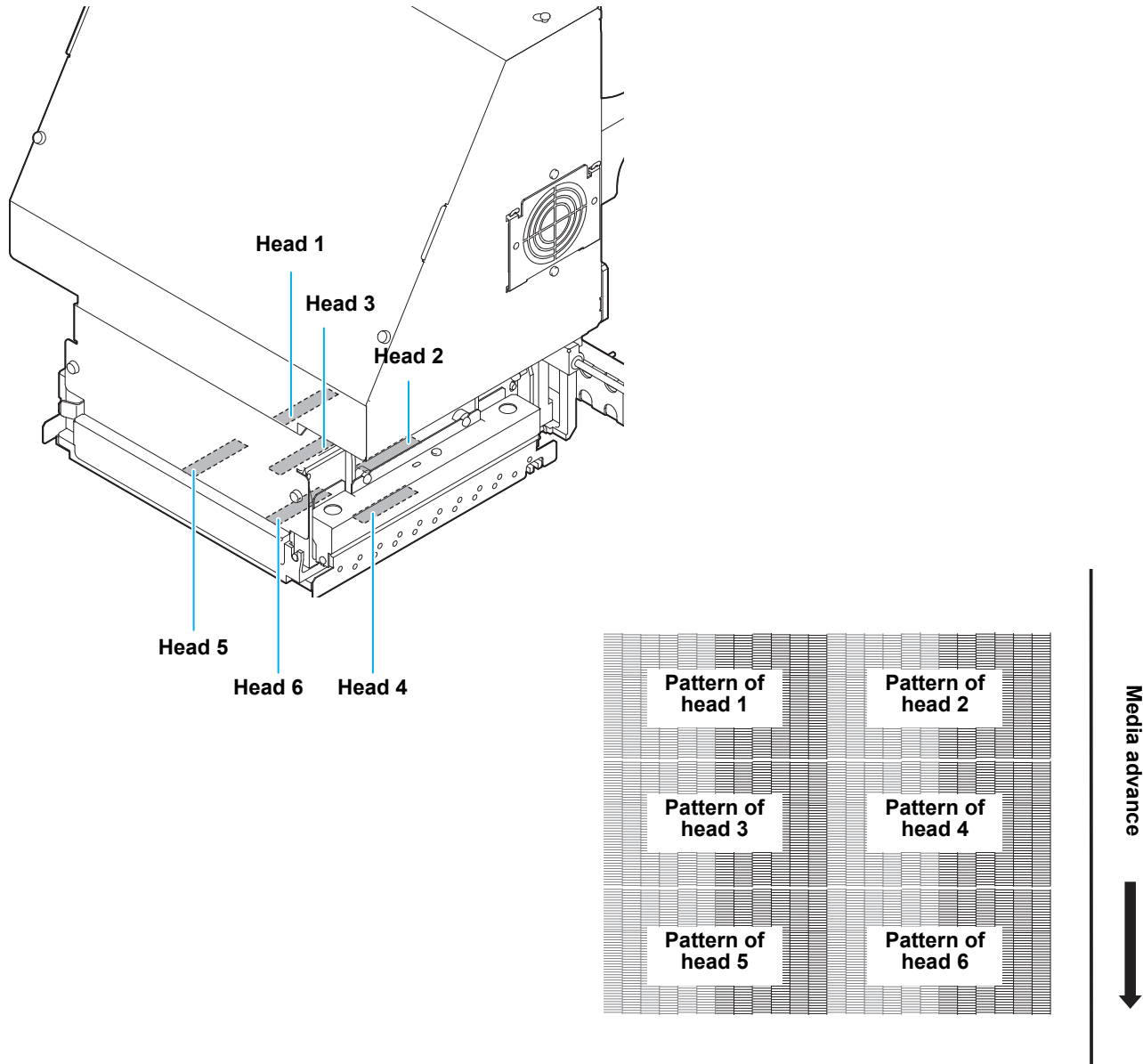

## Test Printing

Print a test pattern to check that there are no discharging defects such as nozzle clogging (slight touching of ink or nozzle missing).

In addition, you can select the orientation of the test pattern to print from two types in order to perform test printing repeatedly. Select one depending on your use.

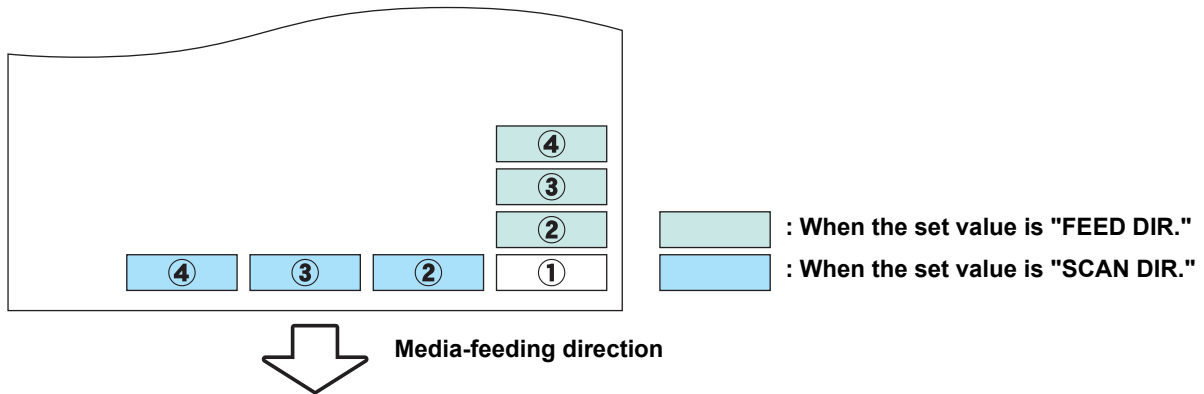

<b>Check before test printing.</b>	• If a media has been set (☞ P.2-11)	• If the origin position has been set
	• If the head height has been adjusted (☞ P.2-23)	

- 1** Press the **TEST PRINT/CLEANING** key in LOCAL.

  - Press **▲** **▼** to change the test pattern orientation.

TEST PRINT  
 (FEED DIR.) [ENT]

---

- 2** Press the **ENTER** key.

  - Test printing starts.
  - When the printing has been completed, the screen returns to step1.

\*\* PRINTING \*\*  
 PLEASE WAIT

TEST PRINT  
 (FEED DIR.) [ENT]

---

- 3** Check the printed test pattern.

  - When the result is normal, end the operation.
  - When the result is abnormal, perform head cleaning. (☞ P.2-33)

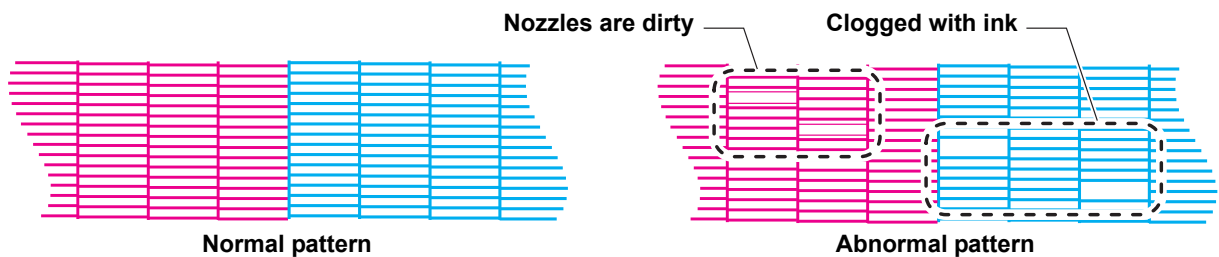



# Head Cleaning

## About head cleaning

Check the printed test pattern result and perform cleaning depending on the status.  
Select one from the three types below:

- SOFT** : When lines are bent, when any line is missing
- NORMAL** : When any line is missing, when colors are mixed
- HARD** : When poor image quality cannot be improved even by NORMAL or SOFT cleaning

## Perform head cleaning depending on the test printing result

There are three types of head cleaning. Use one by checking the test pattern.

1

In Local, Press the **TEST PRINT/CLEANING** key twice.

```
CLEANING
SOFT                               [ ENT ]
```

2

Press **▲** **▼** to select the cleaning type.

- SOFT** : When lines are bent, when any line is missing
- NORMAL** : When any line is missing, when colors are mixed
- HARD** : When poor image quality cannot be improved even by NORMAL or SOFT cleaning

```
CLEANING
NORMAL                              [ ENT ]
```

3

Press the **ENTER** key.

```
SELECT HEAD
: 12
```

4

Press **▲** **▼** to select a head to cleaning.

- Set Value : 12 (Cleaning all heads.)
- 1\_ (Head of Group 1)
- \_2 (Head of Group 2)



Rear side  
of machine

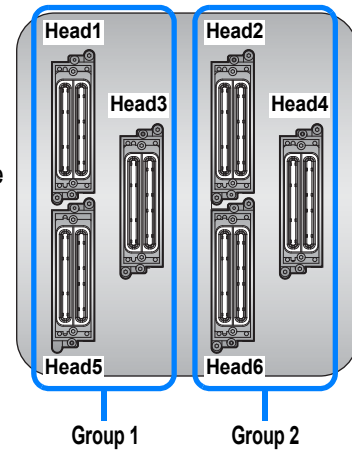

5

Press the **ENTER** key.

```
** CLEANING **
00:00:00
```

6

Perform test printing again, and check the result.

- Repeat the cleaning and the test printing until the drawing result becomes in normal.



**When the image quality is not improved after the head cleaning.**

- Clean the wiper and ink cap. (☞ P.4-6)
- By referring to “When Nozzle Clogging Cannot Be Solved”, set the head nozzle washing (☞ P.4-17) and the nozzle recovery (☞ P.4-19).

2

Basic Operations

# Set the media feeding

Correct the feeding rate of media.

If the correction value is not appropriate, stripes may appear on the printed image, thus resulting in a poor printing.

**Important!**

- When you have changed the media type, check the pattern and perform adjustment depending on the status.
- When printing with a take-up unit, set the media first and then perform media correction.

## Setting Feed Correction

A pattern for media correction is printed and a media-feeding rate is corrected.



- Two bands are printed in the correction pattern.
- Make adjustment so that an even color density is obtained in the boundary between the two bands.

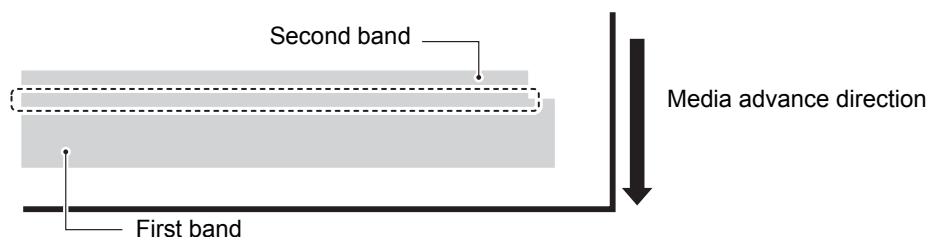

### 1

Set a media. (👉 P.2-11)

### 2

Set the media feeding part to the printable state.

Switch each item below on the operation touch panel:

- Set it to the “AUTOMATIC” screen by pressing [AUTOMATIC].
- Refer to the assistant function (👉 P.2-7) to change the required function to ON.

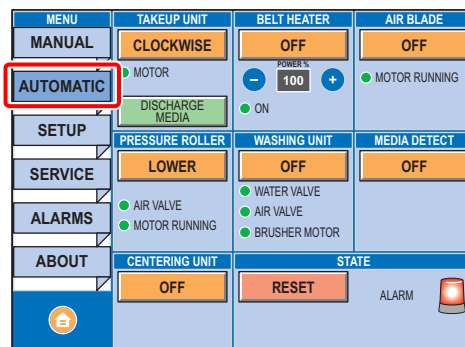

### 3

Press the **ADJUST** key in LOCAL.

FEED COMP. [ENT]

### 4

Press the **ENTER** key.

FEED COMP. PRINT [ENT]

### 5

Press the **ENTER** key to print a correction pattern.

\*\* PRINTING \*\*  
PLEASE WAIT

6

Check the correction pattern and enter a correction value.

```
FEED COMP .
= 0
```

Enter a correction value in "+": The boundary between the two bands is widened.  
Enter a correction value in "-": The boundary between the two bands is narrowed.



- When you change the correction value by "20", the band moves about 0.01mm. By referring to this correction amount, determine the correction value.

7

Press the **ENTER** key.

```
FEED COMP .
PRINT [ENT]
```

- Print a correction pattern again and check it.
- When media correction is needed, perform the operation in Step 5 to make correction.

8

Press the **END** key several times to end the setting.

## Performing the station maintenance without **ADJUST** key

You can select "FEED COMP." by using the **FUNCTION** key in the Local without pressing the **ADJUST** key.

Press the **FUNCTION** key in Local.

Press **▲** **▼** to select [SETUP].

Press the **ENTER** key twice.

- The screen in the Step 3 is displayed. Perform the procedures from the Step 4.

## Correcting Media-feeding during Printing

A media-feeding rate can be corrected even in the remote mode or when image data is printed.

1

Press the **FUNCTION** key in the Remote.

```
*REMOTE*
** . **mm
```

```
FEED COMP .
0 ▶ 0
```

Current [FEED COMP.] value

2

Press **▲** **▼** to enter a corrected feeding rate.

- Corrected feeding rate: -255 to 255
- The value entered here is reflected in the corrected feeding rate soon.

3

Press the **ENTER** key.

```
*REMOTE*
** . **mm
```

- The changed value is registered.
- When you press the **ENTER** key instead of the **END** key, the value entered here will be invalid.

# Correct the ink drop position for bidirectional printing

When the condition for printing (media thickness/head height/etc.) has been changed, perform the following operation to correct the ink drop position for bidirectional (Bi) printing and obtain the proper printing result.

## Example of a Drop Position correct Printed Pattern

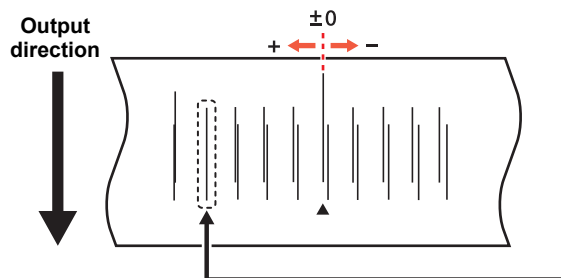

The dots at the fourth position counted from the zero position in the positive direction form a straight line. In this case, the dot position correction value is 4.0.

**1**

Set a media on the machine and set a printing origin. (👉 P.2-11)

**2**

Set the media feeding part to the printable state.

- Switch each item below on the operation touch panel:
- Set it to the “AUTOMATIC” screen by pressing [AUTOMATIC].
  - Refer to the assistant function (👉 P.2-7) to change the required function to ON.

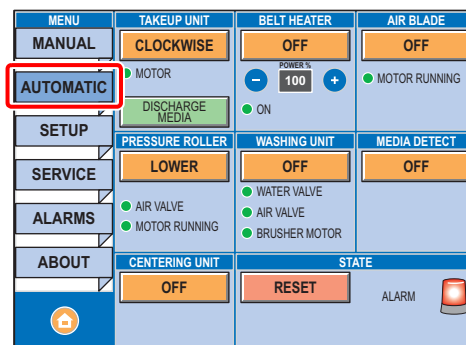

**3**

Press the **ADJUST** key in LOCAL twice.

DROP.POScorrect [ENT]

**4**

Press the **ENTER** key.

DROP.POScorrect PRINT [ENT]

**5**

Press the **ENTER** key to start pattern printing.

- Multiple test patterns are printed. (The printed patterns are called Pattern 1, Pattern 2, Pattern 3... in the order of printing.)

\*\* PRINTING \*\*  
PLEASE WAIT

**6**

Press **▲ ▼** to correct the dot position of Pattern 1~.

PATTERN1  
= 0.0

- **Corrected feeding rate:** -40.0 to 40.0
- Check the test patterns. The position where an outward feeding line and a return feeding line become one straight line is the correction value.
- When the correction value is not between -40.0 and 40.0, adjust the head gap and then perform the operations in Step 2 and later.

**7**

By pressing the **ENTER** key, register the correction value.

- The screen to correct the next pattern is displayed. Repeat the procedures from the Step 5 to correct all patterns.
- After correcting all patterns, perform the procedures in the Step 7.

PATTERN2	
=	0.0

**8**

Press the **END** key several times to end the setting.

### Performing to correct the dot position without **ADJUST** key

You can select "DROP.POScorrect" by using the **FUNCTION** key in the Local without pressing the **ADJUST** key.

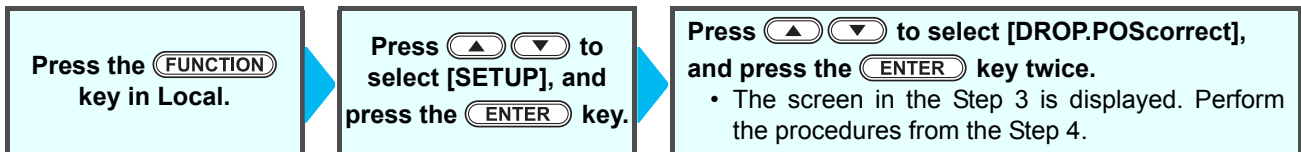

# Printing Data

## Starting a Printing Operation

**Important!**

- When using a roll media, rewind the media by hand before printing so that it is not loose. When the roll media has not been rewound tightly, it may cause the image quality to deteriorate.

### 1 Setting a Media (☞ P.2-11)

### 2 Set the media feeding part to the printable state.

Switch each item below on the operation touch panel:

- Set it to the "AUTOMATIC" screen by pressing [AUTOMATIC].
- Refer to the assistant function (☞ P.2-7) to change the required function to ON.

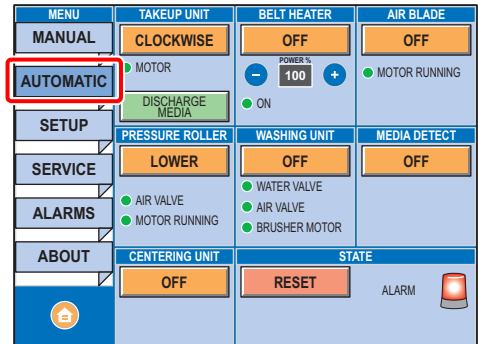

### 3 Press the **REMOTE** key in LOCAL.

- The screen changes to REMOTE, and data can be received from the PC.

### 4 Transmit data to be printed from the PC.

- The printing conditions are displayed.
- For the method of data transmission, see the instruction manual for the output software.

### 5 Start printing.

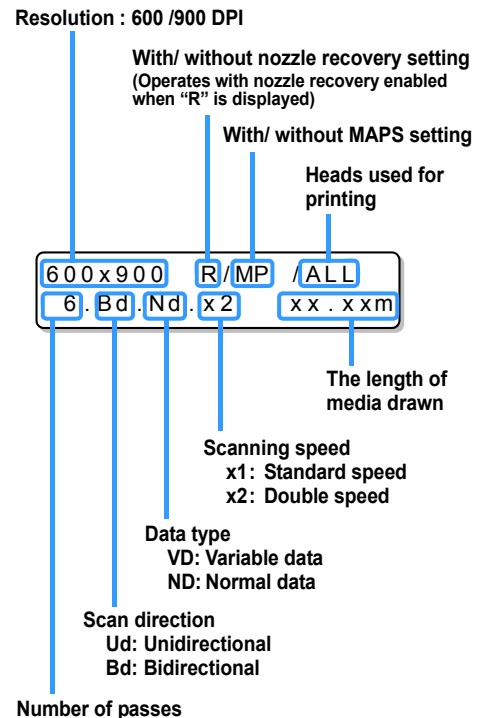

## Stopping a printing operation halfway

Perform the following operation when stopping a printing operation halfway.

# 1

Press the **REMOTE** key during printing.

- The printing operation stops.
- Interrupt data sending at the PC side during the data is sent from the PC.
- Printing restarts from the interrupted data by repressing the **REMOTE** key.

```
<LOCAL>
  DATA REMAIN
```

## Deleting Received Data (Data Clear)

When you want to stop printing, delete the already received data.

# 1

Press the **DATA CLEAR** key in LOCAL.

```
DATA CLEAR
                               [ENT]
```

# 2

Press the **ENTER** key.

- The received data is erased then it returns to the local mode.

```
** DATA CLEAR **
```

# 2





# Chapter 3

## Extended Functions



### This chapter

describes the operation procedures for using the machine more conveniently and each setting procedure.

List of Functions .....	3-2	Selecting the head line to use.....	3-19
Setting Logical Seek .....	3-3	Setting a LANGUAGE.....	3-20
Setting Drying Time .....	3-4	Setting a MEDIA DETECT.....	3-21
Perform setting to reduce stripes between passes .....	3-5	Setting a DRYING FEED .....	3-22
Improving the image quality by changing the media feeding amount .....	3-7	Setting a View Feed.....	3-23
Setting Auto Cleaning .....	3-8	Setting the feed mode of the space of no data to be printed.....	3-24
Setting nozzle face cleaning time .....	3-9	Set the network.....	3-25
Other Settings .....	3-10	Setting event mail function.....	3-27
Machine Settings .....	3-11	Setting the Setting Lock function .....	3-37
Setting a AUTO Power-off.....	3-13	Initializing the Settings .....	3-39
Setting the Display of Media Residual .....	3-14	Confirming Machine Information .....	3-40
Setting Time .....	3-16	Check the using status of the machine.....	3-40
Setting Units.....	3-17	Check the machine version information.....	3-42
Setting a KEY BUZZER .....	3-18	Displaying the Information of this machine .....	3-43

# List of Functions

This section describes the overview of each function to be set and set values that can be registered in user types.



• **About default “HOST” function**

You can operate this by the setting value specified in RIP software.

When you set to other than “HOST”, it operates by that setting value, not by the instruction from RIP software.

Depending on RIP software, there are some functions that cannot be instructed by software. In such a case, it operates by the setting value of “When no instruction from RIP exists”.

- For the specifying method with the RIP software, refer to the operation manual of the RIP software.

Function name	Set value	Default	When no instruction from RIP exists *1	Outline
FEED COMP. (☞ P.2-34)	-9999 ~ 0 ~ 9999	0	————	Used to print a pattern for correcting a media-feeding rate and correct it.
DROP. POS CORRECT (☞ P.2-36)	-40.0 ~ 0 ~ 40.0	0	————	Used to adjust the dot position in go and return printing.
LOGICAL SEEK (☞ P.3-3)	HOST / ON / OFF	HOST	ON	Sets the scan movable area during printing.
INK LAYERS (☞ P.3-10)	HOST / 1 ~ 9	HOST	1	Sets the number of layers in which ink is to be applied.
DRYING TIME (☞ P.3-3)	HOST / 0.0 ~ 9.9 sec	HOST	0 sec	Sets the drying time of ink per scan.
REFRESH (☞ P.3-10)	HOST / Lv.0 (Refresh interval long) ~ 3 (Refresh interval short)	HOST	Lv.3	Refreshes the print heads during printing.
FEED SPEED (☞ P.3-10)	HOST / 10 ~ 200% *2	HOST	100%	Changes the media feeding speed in printing.
MAPS (☞ P.3-5)	PRINT SPEED ADJUST	OFF	————	Perform setting to reduce stripes between passes.
		-50 to +50%	0%	
Belt Encoder (☞ P.3-5)	OFF/ON	OFF	————	Set this to ON when you notice the uneven feeding or the joints of the belt.
AUTO CLEANING (☞ P.3-8)	OFF, PAGE, LENGTH, TIME	OFF*3	————	Sets the automatic cleaning operation for the head performed before printing or during printing.
	PAGE INTERVAL	1 to 1000 page	1 page	
	TYPE	NORMAL / SOFT / HARD	SOFT	
	LENGTH INTERVAL	0.1 to 100.0m	0.5m	
	TYPE	NORMAL / SOFT / HARD	SOFT	
TIME INTERVAL	10 to 120 min	10 min		
TYPE	NORMAL / SOFT / HARD	SOFT		
INTERVAL WIPING (☞ P.3-9)	3 to 255 minutes, OFF	OFF	————	Sets the wiping operation during printing.
HEAD GAP (☞ P.2-23)	1.5 to 7.0mm	2.0 mm	————	Sets the head gap.

\*1. This is the setting value to be used for printing when setting value is not specified at the RIP software (host) side, or, you give priority to the setting value at the machine side, even if you set “Host” to the type registration of this machine.

\*2. When you set this to “100%” or more, required time for completion of printing will be shortened. However, enough drying time cannot be ensured and it may affect the image quality.

\*3. The initial value is “Separated (20.0 mm), SOFT” only during Sb300 filling.

# Setting Logical Seek

The motion of Head varies depending on the set of Logical-seek.

**Important!**

- You cannot specify the logical seek at the RasterLink side. When you set this machine to "Host", printing will be performed in "LOGICAL SEEK=ON" status.

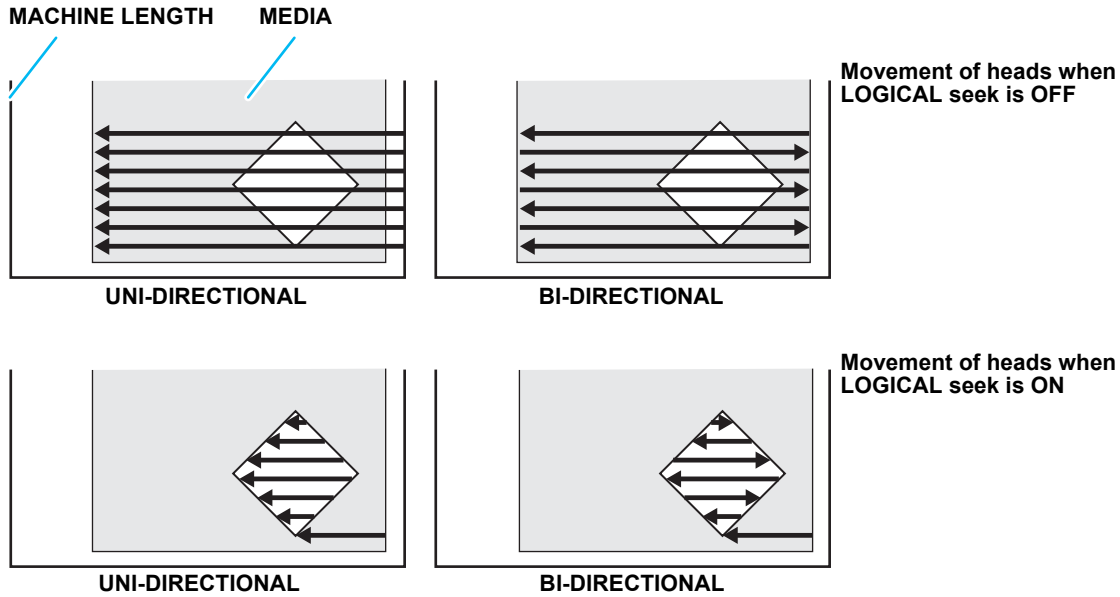

- Press the **FUNCTION** key in LOCAL.
 

FUNCTION  
SETUP [ENT]
- Press the **ENTER** key.
 

SETUP  
FEED COMP. [ENT]
- Press **▲ ▼** to select [LOGICAL SEEK].
 

SETUP  
LOGICAL SEEK [ENT]
- Press the **ENTER** key.
 

LOGICAL SEEK  
:HOST
- Press **▲ ▼** to select a set value.
  - Set value : HOST / ON / OFF

LOGICAL SEEK  
:ON
- Press the **ENTER** key.
 

SETUP  
LOGICAL SEEK [ENT]
- Press the **END** key several times to end the setting.

# Setting Drying Time

In the drying time setting, the ink drying time for each scanning is set. (During bidirectional printing, the machine stops for a certain period of time specified for each of the outward and return scanning.)

- Important!**
- When you give priority to the setting at the RasterLink side, make the setting value "Host".
  - "SCAN" set in this machine is displayed as "Pause Time per Scan" in the RasterLink.

<b>1</b>	Press the <b>FUNCTION</b> key in LOCAL.	FUNCTION SETUP [ENT]
<b>2</b>	Press the <b>ENTER</b> key.	SETUP FEED COMP. [ENT]
<b>3</b>	Press <b>▲▼</b> to select [DRYING TIME].	SETUP DRYING TIME [ENT]
<b>4</b>	Press the <b>ENTER</b> key.	SCAN = HOST
<b>5</b>	Press <b>▲▼</b> to set drying time for scanning. • To enable the drying time specified in your RIP, select "Host". • Scanning setting value : Host or 0.0 sec. to 9.9 sec.	SCAN = HOST
<b>6</b>	Press the <b>ENTER</b> key.	SETUP DRYING TIME [ENT]
<b>7</b>	Press the <b>END</b> key several times to end the setting.	

# Perform setting to reduce stripes between passes

In case that feeding stripes cannot be resolved even though media correction (P.2-34) is performed, make "MAPS" (Mimaki Advanced Pass System) valid. Feeding stripes become less visible by distributing the pass boundary. (Supported from the firmware ver.1.10)



- MAPS effect differs depending on the set value of the printing speed. Use it after checking effect in advance.
- When you speed up the printing speed, it takes shorter time to print. However, MAPS effect becomes weak.
- When you slow down the printing speed, it takes longer time to print. However, MAPS effect becomes strong and feeding stripes become less visible.
- When printing, if you set the printing speed to 0% and more, MAPS becomes invalid. In addition, it prints at 0% speed. When you use MAPS, set the printing speed to "minus (-)".

## For 4-color

Resolution	Pass	Scan speed
300 x 300	1 pass	Normal speed
300 x 300 HQ	2 pass	Normal speed
300 x 450 HQ	3 pass	Normal speed
600 x 600	2 pass	Normal speed
	4 pass	High speed
600 x 900	3 pass	Normal speed
	6 pass	High speed
600 x 1200	4 pass	Normal speed
	8 pass	High speed

## For more than 6-color

Resolution	Pass	Scan speed
300 x 300	2 pass	Normal speed
300 x 300 HQ	4 pass	Normal speed
600 x 450	3 pass	Normal speed
	6 pass	High speed
600 x 600	4 pass	Normal speed
	8 pass	High speed
600 x 900	6 pass	Normal speed
	12 pass	High speed
600 x 1200	8 pass	Normal speed
	16 pass	High speed

**1** Press the **FUNCTION** key in LOCAL.

FUNCTION  
SETUP [ENT]

**2** Press the **ENTER** key.

SETUP  
FEED COMP. [ENT]

**3** Press **▲▼** to select [MAPS].

SETUP  
MAPS [ENT]

**4** Press the **ENTER** key.

MAPS  
: OFF

**5** Press **▲▼** to set ON/OFF.  
• Set Value : ON/OFF

MAPS  
: ON

**6** Press the **ENTER** key.  
• When you select OFF, proceed to the Step 9.

PRINT SPEED ADJUST  
= 0%

**7** Press **▲▼** to change print speed.  
• Set Value : -50 to +50%

PRINT SPEED ADJUST  
= 10%

**Important!** • When you change the speed, nozzle recovery effect cannot work in some cases. Use it after checking.

**8**

Press the **ENTER** key.

SETUP  
MAPS [ENT]

**9**

Press the **END** key several times to end the setting.

# Improving the image quality by changing the media feeding amount

When you set the belt encoder to ON, you can improve the print quality.  
Set this to ON when you notice the uneven feeding or the joints of the belt.

**Important!**

- When you set the belt encoder to ON, print quality improves but print speed declines by 10% compared to when it is set to OFF.

<b>1</b>	Press the <b>FUNCTION</b> key in LOCAL.	FUNCTION SETUP [ENT]
<b>2</b>	Press the <b>ENTER</b> key.	SETUP FEED COMP. [ENT]
<b>3</b>	Press <b>▲</b> <b>▼</b> to select [Belt Encoder].	SETUP Belt Encoder [ENT]
<b>4</b>	Press the <b>ENTER</b> key.	Belt Encoder :OFF
<b>5</b>	Press <b>▲</b> <b>▼</b> to set ON/OFF. • Set Value : ON/OFF	Belt Encoder :ON
<b>6</b>	Press the <b>ENTER</b> key.	SETUP Belt Encoder [ENT]
<b>7</b>	Press the <b>END</b> key several times to end the setting.	







# Setting Auto Cleaning

You can set the machine so that it counts the number of printed files or the length or time after printing has been completed, and performs cleaning automatically if required.

You can select the auto cleaning setting from three types below:

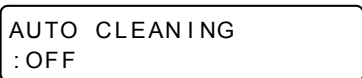
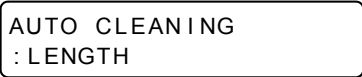
- PAGE : Set the cleaning intervals by the number of printed files.
- LENGTH : Set the cleaning intervals by the printed length.
- TIME : Set the cleaning intervals by the printed time.

The machine can perform a stable printing operation with its heads always kept clean.

- 1** Press the **FUNCTION** key in LOCAL. 
- 2** Press the **ENTER** key. 
- 3** Press **▲▼** to select [AUTO CLEANING] and press the **ENTER** key. 
- 4** Press **▲▼** to select the type of auto cleaning.
  - There are "PAGE", "LENGTH" and "TIME" for auto cleaning.
  - PAGE : When the set number of prints has been completed, the machine performs head cleaning automatically.
  - LENGTH : When the set length has passed, the machine performs head cleaning automatically.
  - TIME : When the set time has passed, the machine performs head cleaning automatically.
  - If you do not set auto cleaning, first select "OFF" and then proceed to the Step 10.
- 5** Press the **ENTER** key.
- 6** Press **▲▼** to set the cleaning interval.
  - Depending on the auto cleaning type selected in the Step 5, the setting value differs.
  - For PAGE : 1 to 1000 page
  - For LENGTH : 0.1 to 100.0m (in 0.1m increment)
  - For TIME : 10 to 120min (in 10min increment)
- 7** Press the **ENTER** key. 
- 8** Press **▲▼** to set the cleaning type.  
Set Value : NORMAL/ SOFT/HARD 
- 9** Press the **ENTER** key.
- 10** Press the **END** key several times to end the setting.

**Important!**

- Depending on the state of the heads, etc., the image quality deterioration may not be improved even with this function performed. In this case, contact our service office or the distributor in your region.



# Setting nozzle face cleaning time

When the set time has passed, nozzle face of the head is cleaned automatically to remove ink droplets on the nozzle face.

In case that deflection, nozzle missing, or symptom which ink droplets fall down occurred, make the interval between each operation shorter.

<b>1</b>	Press the <b>FUNCTION</b> key in LOCAL.	FUNCTION SETUP [ENT]
<b>2</b>	Press the <b>ENTER</b> key.	SETUP FEED COMP. [ENT]
<b>3</b>	Press <b>▲</b> <b>▼</b> to select [INTERVAL WIPING].	SETUP INTERVAL WIPING [ENT]
<b>4</b>	Press the <b>ENTER</b> key.	INTERVAL WIPING :OFF
<b>5</b>	Press <b>▲</b> <b>▼</b> to set intervals. • Set Value : 3 to 255 Minutes, OFF • When [OFF] is set, periodical wiping is not executed.	INTERVAL WIPING :OFF
<b>6</b>	Press the <b>ENTER</b> key.	SETUP INTERVAL WIPING [ENT]
<b>7</b>	Press the <b>END</b> key several times to end the setting.	

# Other Settings

Change the settings according to the types of use.

**1**

Press the **FUNCTION** key in LOCAL.

FUNCTION  
SETUP [ENT]

**2**

Press the **ENTER** key.

SETUP  
FEED COMP. [ENT]

**3**

Press **▲** **▼** to select an item for setting.

- Select it, referring to P.3-2 "List of Functions".

**4**

Press the **ENTER** key.

**5**

Press **▲** **▼** to select the setting value.

- Select it, referring to P.3-2 "List of Functions".

**6**

Press the **ENTER** key.

**7**

Press the **END** key several times to end the setting.

**Important!**

- The set value is retained even when the power is turned "OFF".

# Machine Settings

Machine settings are functions for using this machine easily.  
The following items can be set in Machine settings.

Item		Set value	Default	Meaning	
AUTO Power-off (☞ P.3-13)		NONE/ 10 to 600min	NONE	When no operation has been performed for the set time, the power supply is automatically turned "OFF".	
MEDIA REMAIN (☞ P.3-14)		ON / OFF	OFF	You can control the remaining amount of media.	
TIME SET (☞ P.3-16)		+4h to -20h	Japan time	Time difference is corrected.	
UNIT (☞ P.3-17)	TEMP.	°C (Centigrade) /°F (Fahrenheit)	°C	A unit for displaying temperature is set.	
	LENGTH	mm / inch	mm	A unit for displaying length and area is set.	
KEY BUZZER (☞ P.3-18)		OFF / ON	ON	A buzzer sound when keys are pressed is set.	
HEAD SELECT (☞ P.3-19)		ALL HEAD line 1 HEAD line 2 HEAD line 3 HEAD line 1 & 2 HEAD line 2 & 3	ALL	If a trouble such as nozzle clogging cannot be solved, you can print only with the head without the trouble.	
LANGUAGE (☞ P.3-20)		English ニホンゴ Deutsch Français Español Italiano Português	English	Displayed language is changed.	
MEDIA DETECT (☞ P.3-21)		AUTO/MANUAL	AUTO	When you set the media and if you enter any media thickness, or, when there is a problem to use the media thickness sensor, set it to "MANUAL".	
DRYING FEED (☞ P.3-22)		OFF/100 to 1000mm	OFF	To dry evenly up to the back edge of the printing data, set the length to be fed after printing has been completed.	
View Feed (☞ P.3-23)		OFF/100 ~ 1000mm	OFF	Set to feed media to check the print results such as test prints.	
Space Feed Mode (☞ P.3-24)		INTERMITTENT/ CONTINUOUS	INTERMI TTENT	Change the feed mode of the margin included in the image data.	
NETWORK & MAIL	NETWORK (☞ P.3-25)	Set the network.			
		IP Address	The IP address currently used by this machine is displayed.		
		MAC Address	The IP address currently used by this machine is displayed.		
		DHCP	ON / OFF		When it is ON, the IP address given by the DHCP server is used.
		AutoIP	ON / OFF		When it is ON, the IP address is determined by the AutoIP protocol. However, DHCP is ON, DHCP has priority.
		IP Address *1	Set the IP address used by this machine.		
		Def.Gatew ay *1	Set the default gateway used by this machine.		
		DNS Address *1	Set the DNS server address used by this machine.		
		SubNet Mask *1	Set the digit number of the subnet mask used by this machine.		

Item		Set value		Default	Meaning		
NETWORK & MAIL	EVENT MAIL (☞ P.3-27)	Mail Delivery	ON / OFF		OFF	Set whether you send/ do not send the e-mail when the set event occurs.	
		Select Event	Print Start Event	ON / OFF	OFF	Set whether you send/ do not send the e-mail at the start of printing.	
			Print End Event	ON / OFF	OFF	Set whether you send/ do not send the e-mail at the end of printing.	
			Warning Event	ON / OFF	OFF	Set whether you send/ do not send the e-mail when a warning occurs.	
			Other Event	ON / OFF	OFF	Set whether you send/ do not send the e-mail when an event other than the above occurs.	
		Mail Address	Set the e-mail address to which you send the event mail.		Alphanumeric characters and symbols (within 96 characters)		
		Message Subject	Set the characters to write in the subject of the event mail.		Alphanumeric characters and symbols (within 8 characters)		
		Server Setup	SMTP Address		Set the SMTP server.		
			SMTP PORT No.		Set the SMTP port number.		
			SENDER ADDRESS		Set the e-mail address to be used as the sender mail address.		
			Auth.	POP before SMTP	Set the SMTP server authentication method (SMTP authentication).		
				SMTP Auth			
				OFF			
			USER NAME *2		Set the user name used for the authentication.		
	PASS WORD *2		Set the password used for the authentication.				
	POP3 ADDRESS *3		Set the POP server.				
	APOP *3		Set ON/ OFF of APOP.				
	Transmit Test	Send the test e-mail.					
	SETTING LOCK (☞ P.3-37)	LOCK (Password is not set)	0000 to 9999	0000	You can freely specify a four digit password so that no one other than an administrator can perform network and mail settings.		
		UNLOCK (Password is set)					
RESET(☞ P.3-39)		_____	_____	All setting values are returned to the status default.			

\*1. Settable when both of DHCP and AutoIP are [OFF]

\*2. Settable only when Auth. is not OFF

\*3. Settable only when Auth. is POP before SMTP

## Setting a AUTO Power-off

When no operation has been performed for the set time, the power supply of Media feeding part is automatically turned "OFF".

**1** Press the **FUNCTION** key in LOCAL.

```
FUNCTION
SETUP          [ENT]
```

**2** Press **▲** **▼** to select [MACHINE SETUP].

```
FUNCTION
MACHINE SETUP [ENT]
```

**3** Press the **ENTER** key twice.

```
AUTO Power - off
=                30min
```

**4** Press **▲** **▼** to set time to turn OFF the power supply.

```
AUTO Power - off
=                60min
```

• Set Value : none, 10 to 600min

**5** Press the **ENTER** key.

```
MACHINE SETUP
AUTO Power - off [ENT]
```

**6** Press the **END** key several times to end the setting.

**Important!**

- If it has received data from the PC in the auto-power-off status, the power supply is turned on, however, the printing operation does not start automatically.

## Setting the Display of Media Residual

Whether the screen displays the remaining amount of a media is set.

<b>When the media remaining amount display is turned to "ON"</b>	the remaining amount of a media is displayed in Remote. (However, when a leaf media is used, the length of the media to be printed is displayed.)
<b>When the media remaining amount display is turned to "OFF"</b>	the remaining amount of a media is not displayed in the Remote.



- The amount of a media that has been fed by the printing and jog keys is reflected in the remaining amount of a media.
- The length of a media (initial value of the remaining amount) is entered when a roll media is detected. (P.2-25)
- The setting configured here does not become effective unless media detection is performed after the setting has been complete.

<b>1</b>	Press the <b>FUNCTION</b> key in LOCAL.	FUNCTION SETUP [ENT]
<b>2</b>	Press <b>▲▼</b> to select [MACHINE SETUP].	FUNCTION MACHINE SETUP [ENT]
<b>3</b>	Press the <b>ENTER</b> key.	MACHINE SETUP AUTO Power-off [ENT]
<b>4</b>	Press <b>▲▼</b> to select [MEDIA REMAIN].	MACHINE SETUP MEDIA REMAIN [ENT]
<b>5</b>	Press the <b>ENTER</b> key.	MEDIA REMAIN : OFF
<b>6</b>	Press <b>▲▼</b> to select ON/OFF.	MEDIA REMAIN : ON
<b>7</b>	Press the <b>ENTER</b> key.	MACHINE SETUP MEDIA REMAIN [ENT]
<b>8</b>	Press the <b>END</b> key several times to end the setting.	

## Printing the Remaining Amount of a Media

The present remaining amount of a media can be printed.



- Set "Remaining amount of a media to display" to "ON".
- When you replace the media you use now with another, it is recommended that you print the remaining amount of the media on it. With the remaining amount of a media having been printed beforehand, when you use the replaced media again, you can enter an accurate value in the screen for entering the remaining amount of a media (☞ P.2-25) that appears after media detection.

### 1









In **LOCAL**, Press    .

- LOCAL changes to the origin setting mode.

```
ORIGIN SETUP
0.0  - - - -
```

### 2





Press     to change the value of the origin.

- Move the carriage and media with     and set the origin.
- When you do not change the origin, do not press     and proceed to Step 3.
- When you press the  key here, the origin is changed, and the screen returns to LOCAL.

```
ORIGIN  SETUP
0.0    0.0
Origin  Origin
(Length) (Width)
```

### 3

Press the  key.

- When you press     , the screen returns to Step 2.
- When you press the  key, the screen returns to LOCAL.

```
MEDIA REMAIN PRINT
[ENT]
```

### 4

Press the  key.

- The remaining amount of a media starts to be printed.
- When the printing has been completed, the screen returns to LOCAL.

**Important!**

- When the remaining amount of a media has been printed with the origin changed, the origin set here is effective even when subsequent data are printed.

## Setting Time

You can set time of your country (time difference).

- 1** Press the **FUNCTION** key in LOCAL. FUNCTION  
SETUP [ENT]
- 2** Press **▲▼** to select [MACHINE SETUP]. FUNCTION  
MACHINE SETUP [ENT]
- 3** Press the **ENTER** key. MACHINE SETUP  
AUTO Power-off [ENT]
- 4** Press **▲▼** to select [TIME SET]. MACHINE SETUP  
TIME SET [ENT]
- 5** Press the **ENTER** key. TIME SET  
2012.10.05 21:30:00
- 6** Press **▲▼◀▶** to enter time.  
Year/Month/Day/Time selecting : by the **◀▶** keys.  
Year/Month/Day/Time inputting : by the **▲▼** keys.
- 7** Press the **ENTER** key.  
• The entered date is displayed. TIME SET  
2012.10.05 15:30:00
- 8** Press the **END** key several times to end the setting.



- -20 hours to +4 hours can be set.



## Setting Units

Units used by this machine are set.

- |           |   |                                       |
|-----------|---|---------------------------------------|
| <b>1</b>  | Press the key <b>FUNCTION</b> in LOCAL.                                       | FUNCTION<br>SETUP [ENT]               |
| <b>2</b>  | Press <b>▲▼</b> to select [MACHINE SETUP].                                    | FUNCTION<br>MACHINE SETUP [ENT]       |
| <b>3</b>  | Press the <b>ENTER</b> key.   | MACHINE SETUP<br>AUTO Power-off [ENT] |
| <b>4</b>  | Press <b>▲▼</b> to select [UNIT].   | MACHINE SETUP<br>UNIT [ENT]           |
| <b>5</b>  | Press the <b>ENTER</b> key.   | TEMP.<br>: °C                         |
| <b>6</b>  | Press <b>▲▼</b> to select a unit of the temperature.<br>• Set value : °C / °F |                                       |
| <b>7</b>  | Press the <b>ENTER</b> key.   | LENGTH<br>: mm                        |
| <b>8</b>  | Press <b>▲▼</b> to select a unit of the length.<br>• Set value : mm / inch    |                                       |
| <b>9</b>  | Press the <b>ENTER</b> key.   | MACHINE SETUP<br>UNIT [ENT]           |
| <b>10</b> | Press the <b>END</b> key several times to end the setting.                    |                                       |

## Setting a KEY BUZZER

You can turn off the buzzer sound when pressing the key.

- 1** Press the **FUNCTION** key in LOCAL. FUNCTION  
SETUP <ENT>
- 2** Press **▲ ▼** to select **[MACHINE SETUP]**. FUNCTION  
MACHINE SETUP [ENT]
- 3** Press the **ENTER** key. MACHINE SETUP  
AUTO Power-off [ENT]
- 4** Press **▲ ▼** to select **[KEY BUZZER]**. MACHINE SETUP  
KEY BUZZER [ENT]
- 5** Press the **ENTER** key. KEY BUZZER  
: ON
- 6** Press **▲ ▼** to select **ON/OFF**. KEY BUZZER  
: OFF
- 7** Press the **ENTER** key. MACHINE SETUP  
KEY BUZZER [ENT]
- 8** Press the **END** key several times to end the setting.



- When the key buzzer is set to "OFF", the buzzer sound for errors, warnings, operation completion, etc. cannot be shut off.

## Selecting the head line to use

If troubles such as the nozzle clogging is not solved, you can print with another head which has no error.

- |   |   |                                       |
|---|---|---------------------------------------|
| 1 | Press the <b>FUNCTION</b> key in LOCAL.   | FUNCTION<br>SETUP <ENT>               |
| 2 | Press <b>▲</b> <b>▼</b> to select [MACHINE SETUP].  | FUNCTION<br>MACHINE SETUP [ENT]       |
| 3 | Press the <b>ENTER</b> key.   | MACHINE SETUP<br>AUTO Power-off [ENT] |
| 4 | Press <b>▲</b> <b>▼</b> to select [HEAD SELECT].  | MACHINE SETUP<br>HEAD SELECT [ENT]    |
| 5 | Press the <b>ENTER</b> key.   | HEAD SELECT<br>:ALL                   |
| 6 | Press <b>▲</b> <b>▼</b> to select a head to use.<br><br>Set value:ALL/ HEAD line 1/ HEAD line 2/ HEAD line<br>3/ HEAD line 1 & 2/ HEAD line 2 & 3 | HEAD SELECT<br>:HEAD line1            |
| 7 | Press the <b>ENTER</b> key.   | MACHINE SETUP<br>HEAD SELECT [ENT]    |
| 8 | Press the <b>END</b> key several times to end the setting.  |                                       |

## Setting a LANGUAGE

You can change the displayed language.

- 1** Press the **FUNCTION** key in LOCAL. FUNCTION  
SETUP [ENT]
- 2** Press **▲▼** to select **[MACHINE SETUP]**. FUNCTION  
MACHINE SETUP [ENT]
- 3** Press the **ENTER** key. MACHINE SETUP  
AUTO Power-off [ENT]
- 4** Press **▲▼** to select **[LANGUAGE]**. MACHINE SETUP  
LANGUAGE [ENT]
- 5** Press the **ENTER** key. LANGUAGE  
: English
- 6** Press **▲▼** to select language.  
• Set Value : ニホンゴ / English / Deutsch / Français / Español /  
Italiano / Português MEDIA S IDUAL  
: ニホンゴ
- 7** Press the **ENTER** key. MACHINE SETUP  
LANGUAGE [ENT]
- 8** Press the **END** key several times to end the setting.



- For the language settings of the operation touch panel, see P.1-11 "Language setting".

## Setting a MEDIA DETECT

When you enter any media thickness at setting the media or when the media thickness sensor has an error, set this to "MANUAL".

- |          |  |                                       |
|----------|--|---------------------------------------|
| <b>1</b> | Press the <b>FUNCTION</b> key in LOCAL.                    | FUNCTION<br>SETUP <ENT>               |
| <b>2</b> | Press <b>▲</b> <b>▼</b> to select [MACHINE SETUP].         | FUNCTION<br>MACHINE SETUP [ENT]       |
| <b>3</b> | Press the <b>ENTER</b> key.                                | MACHINE SETUP<br>AUTO Power-off [ENT] |
| <b>4</b> | Press <b>▲</b> <b>▼</b> to select [MEDIA DETECT].          | MACHINE SETUP<br>MEDIA DETECT [ENT]   |
| <b>5</b> | Press the <b>ENTER</b> key.                                | THICKNESS DETECT<br>:AUTO             |
| <b>6</b> | Press <b>▲</b> <b>▼</b> to select "AUTO" or "MANUAL".      | THICKNESS DETECT<br>:MANUAL           |
| <b>7</b> | Press the <b>ENTER</b> key.                                | MACHINE SETUP<br>MEDIA DETECT [ENT]   |
| <b>8</b> | Press the <b>END</b> key several times to end the setting. |                                       |

## Setting a DRYING FEED

To dry evenly up to the back edge of the printing data, set the length to be fed after printing has been completed. Depending on your external heater position, set it so that the data end may be fed until it passes the external heater.

- 1** Press the **FUNCTION** key in LOCAL. 

FUNCTION SETUP	<ENT>
-------------------	-------
- 2** Press **▲▼** to select **[MACHINE SETUP]**. 

FUNCTION MACHINE SETUP	[ENT]
---------------------------	-------
- 3** Press the **ENTER** key. 

MACHINE SETUP AUTO Power-off	[ENT]
---------------------------------	-------
- 4** Press **▲▼** to select **[DRYING FEED]**. 

MACHINE SETUP DRYING FEED	[ENT]
------------------------------	-------
- 5** Press the **ENTER** key. 

DRYING FEED =	300mm
------------------	-------
- 6** Press **▲▼** to select the feeding length.  
• Set value : OFF / 100 to 1000mm 

DRYING FEED =	600mm
------------------	-------
- 7** Press the **ENTER** key. 

MACHINE SETUP DRYING FEED	[ENT]
------------------------------	-------
- 8** Press the **END** key several times to end the setting.

## Setting a View Feed

Set to feed media to check the print results such as test prints.

- 1** Press the **FUNCTION** key in LOCAL.

FUNCTION  
 SETUP <ENT>
- 2** Press **▲** **▼** to select [MACHINE SETUP].

FUNCTION  
 MACHINE SETUP [ENT]
- 3** Press the **ENTER** key.

MACHINE SETUP  
 AUTO Power-off [ENT]
- 4** Press **▲** **▼** to select [View Feed].

MACHINE SETUP  
 View Feed [ENT]
- 5** Press the **ENTER** key.

View Feed  
 = OFF
- 6** Press **▲** **▼** to select ON or OFF.  
 • Set value : ON / OFF

View Feed  
 = ON
- 7** Press the **ENTER** key.

MACHINE SETUP  
 View Feed [ENT]
- 8** Press the **END** key several times to end the setting.

## Setting the feed mode of the space of no data to be printed

Change the feed mode of the margin included in the image data (the space of no data to be printed). If print data with much margin, set to "CONTINUOUS", then the print time can be shorten.

- 1** Press the **FUNCTION** key in LOCAL. 

FUNCTION SETUP	<ENT>
-------------------	-------
- 2** Press **▲** **▼** to select [MACHINE SETUP]. 

FUNCTION MACHINE SETUP	[ENT]
---------------------------	-------
- 3** Press the **ENTER** key. 

MACHINE SETUP AUTO Power-off	[ENT]
---------------------------------	-------
- 4** Press **▲** **▼** to select [SPACE BTWN PP.]. 

MACHINE SETUP Space Feed Mode	[ENT]
----------------------------------	-------
- 5** Press the **ENTER** key. 

Space Feed Mode =	INTERMITTENT
----------------------	--------------
- 6** Press **▲** **▼** to set the feed mode.  
**INTERMITTENT** : Perform intermittent feed operation of the path  
division unit  
**CONTINUOUS** : Feed the no data part at a time 

Space Feed Mode =	CONTINUOUS
----------------------	------------
- 7** Press the **ENTER** key. 

MACHINE SETUP SPACE BTWN PP.	[ENT]
---------------------------------	-------
- 8** Press the **END** key several times to end the setting.



## Set the network

You can also perform network setting with "Network Configurator", the tool to perform network setting of Mimaki's product. To download the Network Configurator, check "Driver / Utility" on the download page at Mimaki Engineering (<http://mimaki.com/download/>).

<b>1</b>	Press the <b>FUNCTION</b> key in LOCAL.	FUNCTION SETUP [ENT]
<b>2</b>	Press <b>▲</b> <b>▼</b> to select <b>[MACHINE SETUP]</b> .	FUNCTION MACHINE SETUP [ENT]
<b>3</b>	Press the <b>ENTER</b> key.	MACHINE SETUP AUTO Power-off [ENT]
<b>4</b>	Press <b>▲</b> <b>▼</b> to select <b>[NETWORK &amp; MAIL]</b> .	MACHINE SETUP NETWORK & MAIL [ENT]
<b>5</b>	Press the <b>ENTER</b> key twice.	NETWORK Check IP Addr. [ENT]
<b>6</b>	Press the <b>ENTER</b> key. <ul style="list-style-type: none"> <li>The IP address currently used by this machine is displayed.</li> </ul>  <ul style="list-style-type: none"> <li>After connecting with the network, it takes time until the IP address is determined. If the IP address has not been determined, "0.0.0.0" is displayed.</li> </ul>	Check IP Address 10.16.168.235
<b>7</b>	Press the <b>ENTER</b> key.	NETWORK Check IP Addr. [ENT]
<b>8</b>	Press <b>▲</b> <b>▼</b> to select <b>[MAC Addr.]</b> .	NETWORK Check MAC Addr. [ENT]
<b>9</b>	Press the <b>ENTER</b> key. <ul style="list-style-type: none"> <li>The MAC address currently used by this machine is displayed.</li> </ul>	Check MAC Address 00:0d:1b:00:00:00
<b>10</b>	Press the <b>ENTER</b> key.	NETWORK Check MAC Addr. [ENT]
<b>11</b>	Press <b>▲</b> <b>▼</b> to select <b>[DHCP]</b> .	NETWORK DHCP [ENT]

**12**Press the **ENTER** key.

- Press **▲** **▼** to set ON/ OFF.
- When it is ON, the IP address given by the DHCP server is used.

DHCP
: ON

**13**Press the **ENTER** key.

NETWORK
DHCP [ ENT ]

**14**Press **▲** **▼** to select [AutoIP].

NETWORK
AutoIP [ ENT ]

**15**Press the **ENTER** key.

- Press **▲** **▼** to set ON/ OFF.
- When it is ON, the IP address is determined by the AutoIP protocol. However, DHCP is ON, DHCP has priority.

AutoIP
: ON

**16**Press the **ENTER** key.

NETWORK
AutoIP [ ENT ]

**17**Press **▲** **▼** to select the set values.

- Both of DHCP and AutoIP is OFF, you can set IP Address/ Default Gateway/ DNS Address/ Sub Net Mask. For other than above, proceed to the Step 21.

**18**Press the **ENTER** key.**19**Press **▲** **▼** **◀** **▶** to select the set values.**20**Press **ENTER** to confirm the value.**21**Press the **END** key several times for terminating this function.

- To reflect network setting, once turn off the power supply and then turn it on again.

## Setting event mail function

Set the function to send e-mails to the set e-mail address when events such as cutting start/ end and stop due to an error.

You can also perform network setting with "Network Configurator", the tool to perform network setting of Mimaki's product. To download the Network Configurator, check "Driver / Utility" on the download page at Mimaki Engineering (<http://mimaki.com/download/>).

### Disclaimer

- The customer is responsible for the communication fee for Internet communication such as e-mail notification.
- The notification by the event mail function may not be delivered due to Internet environment, failure of the device/ the power supply, etc. Mimaki has absolutely no responsibility for any damages or loss resulting from non-delivery or delays.

### Important!

- You can use event mail function by connecting LAN to this machine. Please prepare for LAN cable connection beforehand.
- Not compatible with SSL communication.

## Enable the event mail function

<b>1</b>	Press the <b>FUNCTION</b> key in LOCAL.	FUNCTION SETUP [ENT]
<b>2</b>	Press <b>▲▼</b> to select [MACHINE SETUP].	FUNCTION MACHINE SETUP [ENT]
<b>3</b>	Press the <b>ENTER</b> key.	MACHINE SETUP AUTO Power-off [ENT]
<b>4</b>	Press <b>▲▼</b> to select [NETWORK & MAIL].	MACHINE SETUP NETWORK & MAIL [ENT]
<b>5</b>	Press the <b>ENTER</b> key.	NETWORK & MAIL NETWORK [ENT]
<b>6</b>	Press <b>▲▼</b> to select [EVENT MAIL].	MACHINE SETUP EVENT MAIL [ENT]
<b>7</b>	Press the <b>ENTER</b> key.	EVENT MAIL Mail Delivery [ENT]
<b>8</b>	Press the <b>ENTER</b> key.	Mail Delivery :OFF
<b>9</b>	Press <b>▲▼</b> to select "ON".	Mail Delivery :ON

**10**Press the **ENTER** key.

EVENT MAIL Mail Delivery [ENT]
-----------------------------------

**11**Press the **END** key several times for terminating this function.

## Set the event to send an event mail

**1**Press the **FUNCTION** key in LOCAL.

FUNCTION SETUP [ENT]
-------------------------

**2**Press **▲** **▼** to select [MACHINE SETUP].

FUNCTION MACHINE SETUP [ENT]
---------------------------------

**3**Press the **ENTER** key.

MACHINE SETUP AUTO Power-off [ENT]
---------------------------------------

**4**Press **▲** **▼** to select [NETWORK & MAIL].

MACHINE SETUP NETWORK & MAIL [ENT]
---------------------------------------

**5**Press the **ENTER** key.

NETWORK & MAIL NETWORK [ENT]
---------------------------------

**6**Press **▲** **▼** to select [EVENT MAIL].

MACHINE SETUP EVENT MAIL [ENT]
-----------------------------------

**7**Press the **ENTER** key.

EVENT MAIL Mail Delivery [ENT]
-----------------------------------

**8**Press the jog key **▲** or **▼** to select [Select Event].

EVENT MAIL Select Event [ENT]
----------------------------------

**9**Press the **ENTER** key.

- Set whether you send/ do not send the e-mail at the start of plotting.
- Press **▲** **▼** to set ON/ OFF.

Print Start Event :OFF
---------------------------

**10**Press the **ENTER** key.

- Set whether you send/ do not send the e-mail at the end of plotting.
- Press **▲** **▼** to set ON/ OFF.

Print End Event :OFF
-------------------------

- 11** Press the **ENTER** key.
- Set whether you send/ do not send the e-mail when the printing operation stops because an error occurs.
  - Press **▲** **▼** to set ON/ OFF.
- Error Evenn  
:OFF
- 
- 12** Press the **ENTER** key.
- Set whether you send/ do not send the e-mail when a warning occurs during printing.
  - Press **▲** **▼** to set ON/ OFF.
- Warning Event  
:OFF
- 
- 13** Press the **ENTER** key.
- Set whether you send/ do not send the e-mail when an event other than the above occurs.
  - Press **▲** **▼** to set ON/ OFF.
- Other Event  
:OFF
- 
- 14** Press the **ENTER** key.
- EVENT MAIL  
Select Event [ENT]
- 
- 15** Press the **END** key several times for terminating this function.

### Set the e-mail address

- 1** Press the **FUNCTION** key in LOCAL.
- FUNCTION  
SETUP [ENT]
- 
- 2** Press **▲** **▼** to select **[MACHINE SETUP]**.
- FUNCTION  
MACHINE SETUP [ENT]
- 
- 3** Press the **ENTER** key.
- MACHINE SETUP  
AUTO Power-off [ENT]
- 
- 4** Press **▲** **▼** to select **[NETWORK & MAIL]**.
- MACHINE SETUP  
NETWORK & MAIL [ENT]
- 
- 5** Press the **ENTER** key.
- NETWORK & MAIL  
NETWORK [ENT]
- 
- 6** Press **▲** **▼** to select **[EVENT MAIL]**.
- MACHINE SETUP  
EVENT MAIL [ENT]

**7**Press the **ENTER** key.EVENT MAIL  
Mail Delivery [ENT]**8**Press **▲▼** to select [Mail Address].EVENT MAIL  
Mail Address [ENT]**9**Press the **ENTER** key.

Mail Address

**10**Press **▲▼◀▶** to set mail address.

- Set the e-mail address to which you send the event mail.
- Set it with alphanumeric characters and symbols within 96 characters.

**11**Press the **ENTER** key.EVENT MAIL  
Mail Address [ENT]**12**Press the **END** key several times for terminating this function.

## Set the subject

**1**Press the **FUNCTION** key in LOCAL.FUNCTION  
SETUP [ENT]**2**Press **▲▼** to select [MACHINE SETUP].FUNCTION  
MACHINE SETUP [ENT]**3**Press the **ENTER** key.MACHINE SETUP  
AUTO Power-off [ENT]**4**Press **▲▼** to select [NETWORK & MAIL].MACHINE SETUP  
NETWORK & MAIL [ENT]**5**Press the **ENTER** key.NETWORK & MAIL  
NETWORK [ENT]**6**Press **▲▼** to select [EVENT MAIL].MACHINE SETUP  
EVENT MAIL [ENT]

- 7** Press the **ENTER** key.
- EVENT MAIL  
Mail Delivery [ENT]
- 8** Press **▲** **▼** to select [Message Subject].
- EVENT MAIL  
Message Subject [ENT]
- 9** Press the **ENTER** key.
- Message Subject  
Tx500-#1 [ENT]
- 10** Press **▲** **▼** **◀** **▶** to set subject
- Set the characters to write in the subject of the event mail.
  - Set it with alphanumeric characters and symbols within 8 characters.
- 11** Press the **ENTER** key.
- EVENT MAIL  
Message Subject [ENT]
- 12** Press the **END** key several times for terminating this function.

### Set the server

- 1** Press the **FUNCTION** key in LOCAL.
- FUNCTION  
SETUP [ENT]
- 2** Press **▲** **▼** to select [MACHINE SETUP].
- FUNCTION  
MACHINE SETUP [ENT]
- 3** Press the **ENTER** key.
- MACHINE SETUP  
AUTO Power-off [ENT]
- 4** Press **▲** **▼** to select [NETWORK & MAIL].
- MACHINE SETUP  
NETWORK & MAIL [ENT]
- 5** Press the **ENTER** key.
- NETWORK & MAIL  
NETWORK [ENT]
- 6** Press **▲** **▼** to select [EVENT MAIL].
- MACHINE SETUP  
EVENT MAIL [ENT]





7	Press the <b>ENTER</b> key.	EVENT MAIL Mail Delivery [ENT]
8	Press <b>▲</b> <b>▼</b> to select [Server Setup] .	EVENT MAIL Server Setup [ENT]
9	Press the <b>ENTER</b> key.	SERVER SETUP SMTP Address [ENT]
10	Press the <b>ENTER</b> key. • Press the jog key <b>▲</b> <b>▼</b> <b>◀</b> <b>▶</b> to set SMTP server. • Input the SMYP server name.	SMTP Address
11	Press the <b>ENTER</b> key.	SERVER SETUP SMTP Address [ENT]
12	Press <b>▲</b> <b>▼</b> to select [SMTP Port No.] .	SERVER SETUP SMTP Port No. [ENT]
13	Press the <b>ENTER</b> key.	SMTP Port No. : 25
14	Press <b>▲</b> <b>▼</b> to set [SMTP Port] . • Set the SMTP port number.	
15	Press the <b>ENTER</b> key.	SERVER SETUP SMTP Port No. [ENT]
16	Press the jog key <b>▲</b> or <b>▼</b> to select [Authentication] .	SERVER SETUP Authentication [ENT]
17	Press the <b>ENTER</b> key.	Authentication :POP before SMTP
18	Press <b>▲</b> <b>▼</b> to set authentication method . • Set the authentication method of the SMTP server. • When you select [OFF], proceed to the Step 32.	Authentication :POP before SMTP
19	Press the <b>ENTER</b> key.	SERVER SETUP Authentication [ENT]



**20** Press   to select [SENDER ADDRESS].

```
SERVER SETUP
SENDER ADDRESS [ENT]
```

**21** Press the  key.

- Press     and set the e-mail address to be used as the sender mail address.
- Set it with alphanumeric characters and symbols within 64 characters.



- Depending on your server, if you do not set the e-mail address not supporting the account, sending/ receiving e-mails may be unavailable.

```
SENDER ADDRESS
```





**22** Press the  key.

```
SERVER SETUP
SENDER ADDRESS [ENT]
```

**23** Press   to select [User Name].

```
SERVER SETUP
User Name [ENT]
```

**24** Press the  key.

- Press     to set the user name to use for the authentication.
- Set it with alphanumeric characters and symbols within 30 characters.

```
User Name
```





**25** Press the  key.

```
SERVER SETUP
User Name [ENT]
```

**26** Press   to select [Pass Word] .

```
SERVER SETUP
Pass Word [ENT]
```

**27** Press the  key.

- Press     to set the password to use for the authentication.
- Set it with alphanumeric characters and symbols within 15 characters.



- On the password setting screen, you can only check the value that you are currently inputting.

```
Pass Word
*****
```

**28** Press the  key.

- When you select [POP before SMTP] in the Step 16, set the items in the Step 27 to 31.

```
SERVER SETUP
Pass Word [ENT]
```

**29** Press   to select [POP3 Address.] .

```
SERVER SETUP
POP3 Address [ENT]
```

**30**

Press the **ENTER** key.

- Press the jog key     to set POP server.
- Input the POP server name.

POP3 Address

**31**

Press the **ENTER** key.

SERVER SETUP  
POP3 Address [ENT]



**32**

Press   to select [APOP] .

SERVER SETUP  
APOP [ENT]

**33**

Press the **ENTER** key.

- Press   to set ON/ OFF of APOP.

APOP  
: ON

**34**

Press the **ENTER** key.

SERVER SETUP  
APOP [ENT]

**35**

Press the **END** key several times for terminating this function.

## Send a test e-mail

- 1 Press the **FUNCTION** key in LOCAL. FUNCTION  
SETUP [ENT]
- 2 Press **▲▼** to select [MACHINE SETUP]. FUNCTION  
MACHINE SETUP [ENT]
- 3 Press the **ENTER** key. MACHINE SETUP  
AUTO Power-off [ENT]
- 4 Press **▲▼** to select [NETWORK & MAIL]. MACHINE SETUP  
NETWORK & MAIL [ENT]
- 5 Press the **ENTER** key. NETWORK & MAIL  
NETWORK [ENT]
- 6 Press **▲▼** to select [EVENT MAIL]. MACHINE SETUP  
EVENT MAIL [ENT]
- 7 Press the **ENTER** key. EVENT MAIL  
Mail Delivery [ENT]
- 8 Press **▲▼** to select [Transmit Test] . EVENT MAIL  
Transmit Test [ENT]
- 9 Press the **ENTER** key. Transmit Test  
EXECUTE [ENT]
- 10 Press the **ENTER** key. Transmit Test  
Success [ENT]
  - The sent result is displayed.
  - If sending test e-mail has failed, an error code is displayed.  
Refer to the next page to solve the problem.

Transmit Test  
 Failed: 12345 :ent  
Error code
- 11 Press the **END** key several times for terminating this function.

**Important!**

- The sent result of the test e-mail is the result of e-mail sending process performed by this machine to the e-mail server. It does not indicate that the e-mail was received at the address.
- If the spam e-mail filter etc. has been set in the terminal in which e-mails are received, even if "Sending has been completed" is displayed, the e-mail cannot be received in some cases.
- If sending test e-mail has failed, the error code below is displayed.
- If the error cannot be solved, try again after a while.
- For the server setting etc., contact with the network administrator or the provider.

Error Code	The expected casus	Remedy
<b>10</b>	Network connection error	<ul style="list-style-type: none"> <li>• Check that the machine is connected with the network.</li> <li>• Check that the machine IP address is correct.</li> <li>• Check that the machine is in the environment where DNS is available.</li> </ul>
<b>20</b>	No valid e-mail address.	<ul style="list-style-type: none"> <li>• Enter the correct e-mail address.</li> </ul>
<b>11003</b> <b>11004</b>	The POP server cannot be found. Or cannot access DNS server.	<ul style="list-style-type: none"> <li>• Check the POP server address.</li> <li>• Check that the machine is in the environment where DNS is available.</li> </ul>
<b>11021</b>	Cannot connect with the POP server.	<ul style="list-style-type: none"> <li>• Check the POP server setting.</li> <li>• Check the firewall setting.</li> </ul>
<b>12010</b>	An error returns from the POP server.	<ul style="list-style-type: none"> <li>• Check the POP server setting.</li> </ul>
<b>13000</b>	The POP authentication has failed.	<ul style="list-style-type: none"> <li>• Check the user name and the password.</li> <li>• Check the APOP setting.</li> <li>• Confirm the authentication method.</li> </ul>
<b>10013</b> <b>10014</b>	The SMTP server cannot be found. Or cannot access DNS server.	<ul style="list-style-type: none"> <li>• Check the SMTP server address.</li> <li>• Check that the machine is in the environment where DNS is available.</li> </ul>
<b>10021</b>	Cannot connect with the SMTP server.	<ul style="list-style-type: none"> <li>• Check the SMTP server setting.</li> <li>• Check the SMTP port number.</li> <li>• Check the firewall setting.</li> </ul>
<b>10***</b> <b>11***</b> <b>20***</b> <b>21***</b>	An error returns from the SMTP server.	<ul style="list-style-type: none"> <li>• Check the SMTP server setting.</li> <li>• Cannot communicate with a server that requires mandatory SSL communication.</li> <li>• Check protocol filter settings.</li> </ul>
<b>12***</b>	It is invalid sender address.	<ul style="list-style-type: none"> <li>• Check that the e-mail address supporting the account entered in the user name/ the password is set in SENDER ADDRESS.</li> </ul>
<b>13***</b>	The e-mail address cannot be found.	<ul style="list-style-type: none"> <li>• Check the e-mail address.</li> <li>• Even if there is a mistake in the e-mail address, this error cannot be detected in some cases.</li> </ul>
<b>22000</b> <b>22008</b>	SMTP authentication error	<ul style="list-style-type: none"> <li>• Confirm the authentication method.</li> </ul>
<b>23***</b> <b>24***</b> <b>25***</b>	The SMTP authentication has failed.	<ul style="list-style-type: none"> <li>• Check the user name and the password.</li> </ul>

“\*\*\*” is the error code returned from the e-mail server.

## Setting the Setting Lock function

You can freely specify a four digit password so that no one other than an administrator can perform network and mail settings.

### Specifying the password for the network and event mail functions

- 1** Press the **FUNCTION** key in LOCAL.

FUNCTION  
SETUP [ENT]
- 2** Press **▲** **▼** to select [MACHINE SETUP].

FUNCTION  
MACHINE SETUP [ENT]
- 3** Press the **ENTER** key.

MACHINE SETUP  
AUTO Power-off [ENT]
- 4** Press **▲** **▼** to select [NETWORK & MAIL].

MACHINE SETUP  
NETWORK & MAIL [ENT]
- 5** Press the **ENTER** key.

NETWORK & MAIL  
NETWORK [ENT]
- 6** Press **▲** **▼** to select [SETTING LOCK].

MACHINE SETUP  
SETTING LOCK [ENT]
- 7** Press the **ENTER** key.

SETTING LOCK  
LOCK : 0000
- 8** Specify a freely chosen password (four digits) and press the **ENTER** key.

SETTING LOCK  
LOCK START : ????

• A notification that setting has started is briefly displayed.
- 9** Press the **END** key several times for terminating this function.

## Releasing the password for the network and event mail functions

- 1** Press the **FUNCTION** key in LOCAL.

FUNCTION  
SETUP [ENT]
- 2** Press **▲▼** to select [MACHINE SETUP].

FUNCTION  
MACHINE SETUP [ENT]
- 3** Press the **ENTER** key.

MACHINE SETUP  
AUTO Power-off [ENT]
- 4** Press **▲▼** to select [NETWORK & MAIL].

MACHINE SETUP  
NETWORK & MAIL [ENT]
- 5** Press the **ENTER** key.

NETWORK & MAIL  
NETWORK [ENT]
- 6** Press **▲▼** to select [SETTING LOCK].

MACHINE SETUP  
SETTING LOCK [ENT]
- 7** Press the **ENTER** key.

SETTING LOCK  
LOCK :\*\*\*\*
- 8** Enter a four-digit password and press the **ENTER** key.

  - The screen on the right is displayed if releasing is a success.
  - The screen on the right is displayed to notify of failure if releasing is a failure.

SETTING LOCK  
Release Success

SETTING LOCK  
Release failure
- 9** Press the **END** key several times for terminating this function.

**Important!**

- If you forget the password, you can press the **FUNCTION** key displayed in the screen of Step 7 to display the password forced release screen. Be careful as although you can press the **ENTER** key to forcibly release the password, items set for the network and event mail also return to their initial values, making it necessary to re-specify them.

# Initializing the Settings

You can return the setting of "SETUP", "MAINTENANCE" and "MACHINE SETUP" to the status before shipment.

- 1** Press the **FUNCTION** key in LOCAL. 

FUNCTION SETUP	[ ENT ]
-------------------	---------
- 2** Press **▲** **▼** to select **[MACHINE SETUP]**. 

FUNCTION MACHINE SETUP	[ ENT ]
---------------------------	---------
- 3** Press the **ENTER** key. 

MACHINE SETUP AUTO Power-off	[ ENT ]
---------------------------------	---------
- 4** Press **▲** **▼** to select **[RESET]**. 



MACHINE SETUP RESET	[ ENT ]
------------------------	---------
- 5** Press the **ENTER** key. 

RSET ALL SETTING OK?	[ ENT ]
-------------------------	---------
- 6** Press the **ENTER** key.
  - The already configured settings are initialized.

RESET EXECUTE	[ ENT ]
------------------	---------
- 7** Press the **END** key several times to end the setting.

# Confirming Machine Information



The information of this machine can be confirmed.  
The following items can be confirmed as machine information.

Item	Description
ERROR HISTORY	This displays the history of errors and warnings to date. When you press   , the date of occurrence (year/month/day/hour/minute) and the error/warning information are displayed alternately in the order of occurrence.
USAGE	The information of this machine can be confirmed.
WIPING	
PRINT LENGTH	
PRINT AREA	
USE TIME	
HEAD MAINT.	
STATION MAINT.	
NOZZLE WASH	
DISWAY WASH	
CUSTODY WASH	
VERSION	This displays the firmware version for the machine and the information for the main PCB.
LIST	This allows you to print the settings of the machine.
Ink REPL. Report	This prints ink history of this machine.



## Check the using status of the machine

You can check machine information such as wiping information and length printed by this machine.

- 1** Press the  key in LOCAL.
 

FUNCTION  
SETUP [ENT]
- 2** Press   to select [INFORMATION].
 

FUNCTION  
INFORMATION [ENT]
- 3** Press the  key.
 

INFORMATION  
USAGE [ENT]
- 4** Press the  key.
  - The wiping Information is displayed.
  - Every time you press the  key, machine information below are displayed in series.

<b>WIPING</b> Displays wiping information. <div style="border: 1px solid black; padding: 5px; width: fit-content; margin-left: 20px;">                                 WIPING = 0                             </div>	<b>PRINT LENGTH</b> Displays printed length up to now. <div style="border: 1px solid black; padding: 5px; width: fit-content; margin-left: 20px;">                                 PRINT LENGTH = 0m                             </div>
<b>PRINT AREA</b> Displays printed area up to now. <div style="border: 1px solid black; padding: 5px; width: fit-content; margin-left: 20px;">                                 PRINT AREA = 0m<sup>2</sup> </div>	<b>USE TIME</b> Displays used time information of machine. <div style="border: 1px solid black; padding: 5px; width: fit-content; margin-left: 20px;">                                 USE TIME = 0h                             </div>



**HEAD MAINT.**

The elapsed time is displayed when HEAD MAINT. is complete.

HEAD MAINT.  
= 0h

**STATION MAINT.**

The elapsed time is displayed when STATION MAINT. is complete.

STATION MAINT.  
= 0h

**NOZZLE WASH**

The elapsed time is displayed when NOZZLE WASH is complete.

NOZZLE WASH  
= 0h

**DISWAY WASH**

The elapsed time is displayed when DISWAY WASH is complete.

DISWAY WASH  
= 0h

**CUSTODY WASH**

The elapsed time is displayed when CUSTODY WASH is complete.

CUSTODY WASH  
= 0h



- When you reset the used count of the wiper, press the **MAINT.** key while WIPING is displayed. When you press the **ENTER** key, the number of wipings is reset.

WIPING  
RESET? [ENT]

## Check the machine version information

- 1** Press the **FUNCTION** key in LOCAL.

FUNCTION  
SETUP [ENT]
- 2** Press **▲** **▼** to select [INFORMATION].

FUNCTION  
INFORMATION [ENT]
- 3** Press the **ENTER** key.

INFORMATION  
USAGE [ENT]
- 4** Press **▲** **▼** to select [VERSION].

INFORMATION  
VERSION [ENT]
- 5** Press the **ENTER** key.

  - The version Information is displayed.

Tx500-1800B V3.30  
MRL-III V2.20

## Check the Error History

This section describes how to read error history.

**ERROR HISTORY**

Displaying the occurrence date

[00000]  
2014/09/26 22:13:00

◀ ▶

Displaying the contents of error

ERROR 12a  
HDC SPEED

## Check the Substrate Information

Explains the substrate information.

INFORMATION  
VERSION [ENT]

**ENTER**

Tx500-1800B V3.30  
MRL-III V2.20

Displays the version information such as F/W or the like.

**ENTER**

MAIN PCB EPL2B

Displays the Type of Substrate.

Displays the type of main PCB.  
Displays the EPL, EPL2, or EPD2B.

## Displaying the Information of this machine

**1** Press the **ENTER** key in LOCAL.

Sb300	12345678
REMAIN	99999999

**2** The information is displayed sequentially with the **ENTER** key .

- The information shown on the below appear.

Remaining amount of ink	Error (when ink error occurs)	Warning (when warning occurs)
Sb300 12345678 REMAIN 99999999	NON INK IC 12345678	WARNING Replace a Wiper [MNT]
Media width	Head gap	Media thick
MEDIA WIDTH = 1000mm	HEAD GAP = 2.0mm	MEDIA THICKNESS = 0.1mm
Serial No.	Version	Main PCB Information
SERIAL No. :*****	Tx500-1800B V3.30 MRL-III V2.20	MAIN PCB EPL

**RECOVERY NOZZLE**

RECOVERY NOZZLE : \*  
CONFIRM DETAILS [MNT]

Press the **ENTER** key and confirm the description

**3** Press the **ENTER** key to return to LOCAL.



# Chapter 4

## Maintenance



### This chapter

describes the items required to use this machine more comfortably, which are the methods for the daily care, the maintenance of the ink unit etc.





Maintenance .....	4-2	When Nozzle Clogging Cannot	
Precautions for Maintenance .....	4-2	Be Solved .....	4-17
About Cleaning Solution .....	4-2	Washing of Head nozzle .....	4-17
Cleaning the Exterior Surfaces .....	4-3	Alternative nozzles for printing, when nozzles	
Cleaning the Media Sensor .....	4-3	missing can not be improved .....	4-19
When not using the machine for a long		Automatic Maintenance Function .....	4-23
period of time .....	4-4	Setting the Refreshing Intervals .....	4-23
When not using this machine for two days		Setting the Cleaning Intervals .....	4-24
(weekends, etc) .....	4-4	Cleaning Y motor .....	4-25
When not using this machine for more than		Replacing consumables .....	4-26
three days .....	4-5	Replacing the wiper .....	4-26
When using this machine after not having		If a Waste Ink Tank Confirmation Message	
used it for a long period of time .....	4-5	Appears .....	4-27
Maintaining the Capping Station .....	4-6	Cleaning the washing unit .....	4-29
Cleaning the Wiper and Cap .....	4-6	Cleaning of peeling sensor .....	4-30
Cleaning the wiper ink pan .....	4-9	When power of adhesive weakened .....	4-31
Washing the Ink Discharge Passage		Be sure to check before recoating	
(DISWAY WASH) .....	4-11	adhesive .....	4-32
When the Machine Is Not Used for a Long		Peel weakened adhesive .....	4-34
Time (CUSTODY WASH) .....	4-12	Coat new adhesive .....	4-38
Cleaning the Head and the Area			
around It .....	4-15		

# Maintenance

Maintain the machine regularly or as necessary so that its accuracy will be maintained and it can continue to be used for a long time.

## Precautions for Maintenance

Pay attention to the following items when maintaining this machine.

	<ul style="list-style-type: none"><li>• When using cleaning solution for maintenance, be sure to wear the supplied protective glasses.</li></ul>
	<ul style="list-style-type: none"><li>• Never disassemble the machine. Disassembling it can result in electric shock hazards or damage to the machine. Before maintenance, be sure to turn off the power button and main power switch, and unplug the power cable; otherwise, an unexpected accident may occur.</li></ul>
	<ul style="list-style-type: none"><li>• Prevent moisture from entering the machine. Moisture inside the machine can cause electric shock hazards or damage to the machine.</li></ul>
	<ul style="list-style-type: none"><li>• To ensure stable ink jetting, it is necessary for the machine to eject a small amount of ink (flushing) regularly when a printing (outputting) operation has not been performed for a long time.</li><li>• When the machine is not to be used for a long time, turn off only the power button on the front side, leave the main power switch at the side turned ON (in the position of   ), and leave the power cable connected.</li></ul>
	<ul style="list-style-type: none"><li>• Do not use benzene, thinner, or any chemical agent containing an abrasive. Such materials can deteriorate or deform the surface of the cover.</li><li>• Do not apply a lubricant, etc. to any parts inside the machine. Doing so can cause printing failure.</li><li>• Be careful that the cleaning solution, ink, etc. not to stick to the cover because this may cause the surface of the cover to deteriorate or deform.</li></ul>

## About Cleaning Solution

Use the cleaning liquid dedicated for the ink being used.

Type of Ink	Applicable maintenance washings
Sublimation dye ink Reactive dye ink Acid dye ink	Cleaning liquid 03 maintenance kit (ML003-Z-K1)

## Cleaning the Exterior Surfaces

When the exterior surfaces of the machine are stained, dampen a soft cloth with water or a neutral detergent diluted with water, squeeze it, and wipe the surfaces with the cloth.

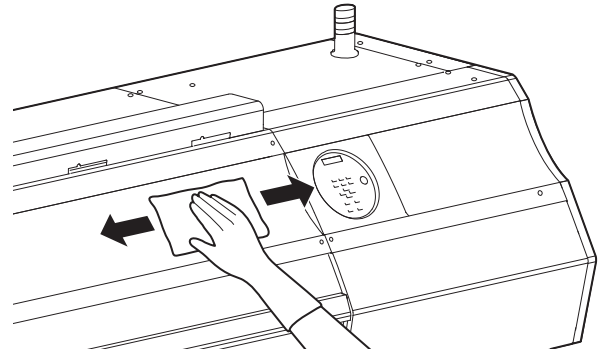

## Cleaning the Media Sensor

When cleaning the sensor on the lower surface of the head is cleaned, move the carriage to the left end by the operations of step 1 of P.4-15 “Cleaning the Head and the Area around It”, and then clean it.

The lower surface of the head

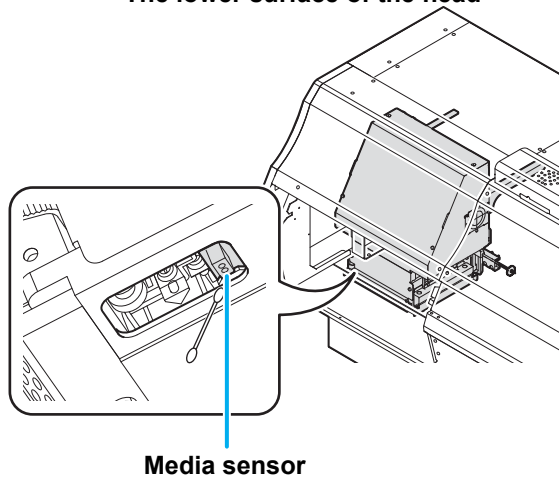

# When not using the machine for a long period of time

**Important!**

- Do not turn off the main power of this machine; doing so will prevent the auto maintenance function to regularly avoid ink clogging from working. To turn off the power, press the power button on the right side of the operation panel and turn off the lamp.

## When not using this machine for two days (weekends, etc)

When you are not using this machine for two days such as on the weekend, follow the procedure below.

**1**

### Perform each item of daily maintenance.

- See P.4-2 for more details on daily maintenance.

**2**

### Insert the safety pins on both sides of the pressure roller.

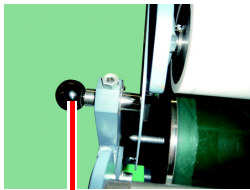

Safety pin

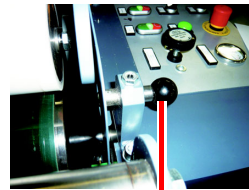
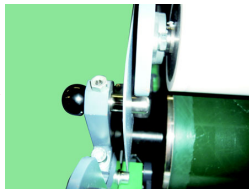

Safety pin



- To avoid the pressure roller from unexpectedly falling and causing injuries, make sure to insert the safety pins securely.

**3**

### Open the draining valve and drain the water from the washing unit.

- Place a bucket below the draining valve before this operation.

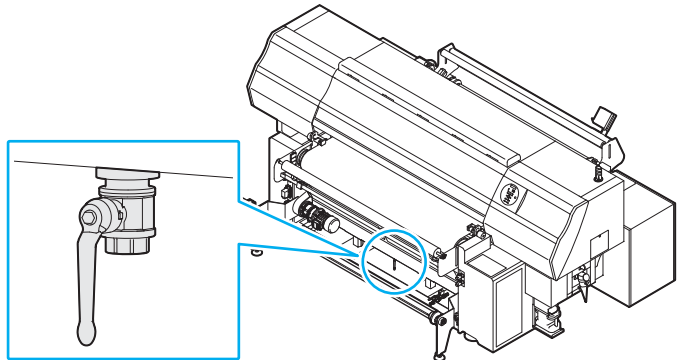

**4**

### Make settings for “Switching ON/OFF of Belt washing function” and “Switching ON/OFF of Belt heater” to OFF.

- See P.2-9 and P.2-10 for more details on the settings.



## When not using this machine for more than three days

When you are not using this machine for more than three days, follow the procedure below.

---

**1** Perform the operation of “When not using this machine for two days (weekends, etc)”.

---

**2** Replace the waste ink tank with a new one.

- See P.4-27 “If a Waste Ink Tank Confirmation Message Appears” for more details on how to replace the waste ink tank.

---

## When using this machine after not having used it for a long period of time

When you have not used this machine for a long period of time and start using this machine again, follow the procedure below.

---

**1** Perform head cleaning (hard) and check the ink nozzles.

- See P.2-33 “Head Cleaning” for more details on head cleaning.

---

**2** If there are some clogged nozzles, perform nozzle washing.

- See P.4-17 “Washing of Head nozzle” for more information.

---

# Maintaining the Capping Station

Maintain the ink cap, wiper, etc. located in the capping station. (STATION MAINT.)

The ink cap and wiper function as follows.

- **Wiper** : It wipes off ink sticking to the head nozzles.
- **Ink cap** : It prevents the head nozzles from clogging due to dryness.

As the machine is used repeatedly, the wiper and ink cap gradually become dirty with ink, dust, etc.

If nozzle missing cannot be corrected even after head cleaning (☞ P.2-33) has been performed, use a Cleaning liquid 03 maintenance kit and clean stick.

Tools required for Maintenance	• Cleaning liquid 03 maintenance kit (ML003-Z-K1)		
	• Clean stick (SPC-0527)	• Gloves	• Goggles



- Be sure to wear the supplied goggles and gloves when maintaining the capping station. Otherwise, you may get ink in your eyes.
- Do not move the carriage out of the capping station by hand. When it is desirable to move the carriage, press the **MAINT.** key to execute the carriage-out. (☞ P.4-6Steps 1 to 2)
- Be sure to perform maintenance for the ink cap and the wiper of capping station every day. If you leave it dirty, dirt may adhere to the nozzle surface, or, dust and dry ink may be rubbed against the nozzle. It may cause discharge defect.

## Cleaning the Wiper and Cap

It is recommended that the wiper and cap be cleaned frequently in order to maintain the high image quality of the machine and keep the machine itself in good working order.

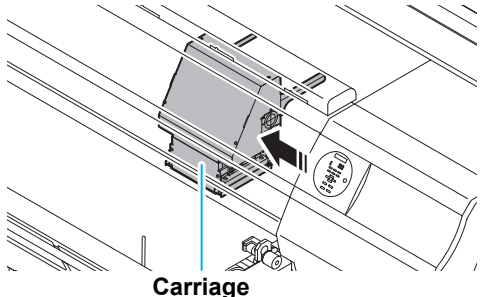

- Clean the wiper and the area around it about twice a week (it varies, depending on frequency in the use of the machine).
- Replace the wiper with a new one when it is extremely dirty or bent. (☞ P.4-26)
- When cleaning the wiper, be careful that lint from the clean stick does not get left on the wiper. Remaining lint may cause image quality to deteriorate.

<b>1</b>	Press the <b>MAINT.</b> key in LOCAL.	CARRIAGE OUT [ ENT ]
<b>2</b>	Press the <b>ENTER</b> key.	MOVE POSITION : STATION MAINT.
<b>3</b>	Press <b>▲ ▼</b> to select [STATION MAINT.].	MOVE POSITION : STATION MAINT.
<b>4</b>	Press the <b>ENTER</b> key. • The carriage moves onto the belt.	

## 5 Open the right maintenance cover.

- (1) Rotate the screws under the right maintenance cover (for three positions) to the left and remove them.
- (2) Hold the bottom of the right maintenance cover and pull it to the front.
- (3) While pulling the right maintenance cover downward, remove it.

- If the right maintenance cover is hard to remove, use the supplied screwdriver.

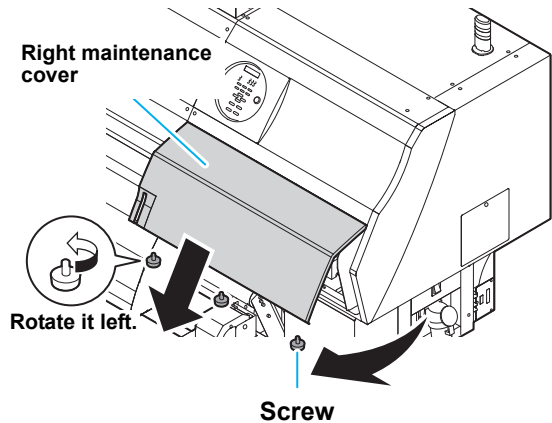

## 6 Remove the wiper.

- Pull out the wiper by holding the protrusions at its both ends.

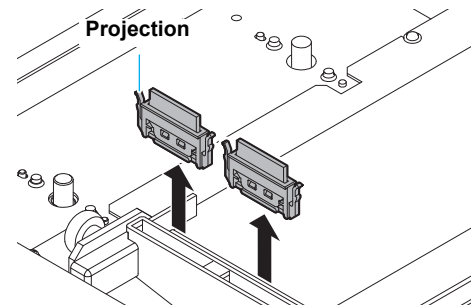

## 7 Clean the wiper and bracket.

- Wipe off the ink sticking to the wiper and bracket with a clean stick dipped in cleaning solution for maintenance. Wipe off so that cleaning solution for maintenance will not remain.

**Important!**

- Clean the wiper and bracket until it looks as shown in the photo on the right.
- After cleaning, make sure that the bracket and wiper are aligned horizontally.

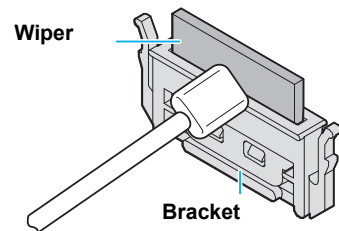

## 8 Clean the wiper slider.

- Wipe off the ink sticking to the wiper slider with a clean stick dipped in cleaning solution for maintenance. Wipe off so that cleaning solution for maintenance will not remain.

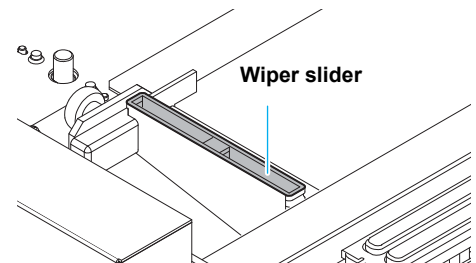

## 9 Set the wiper at the original position.

- Insert the wiper by holding both ends of the wiper.

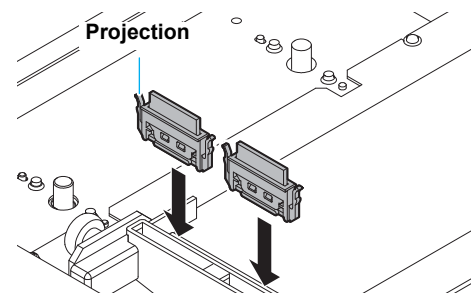

**10****Clean the wiper blade.**

- Soak the clean stick in the maintenance cleaning liquid, and then remove the ink that has adhered to the wiper blade.

**Important!**

- Make sure to be careful with the edge of the wiper blade, and thoroughly clean the side (back side) where the wiper touches.
- Clean the wiper blade until it looks as shown in the photo below.

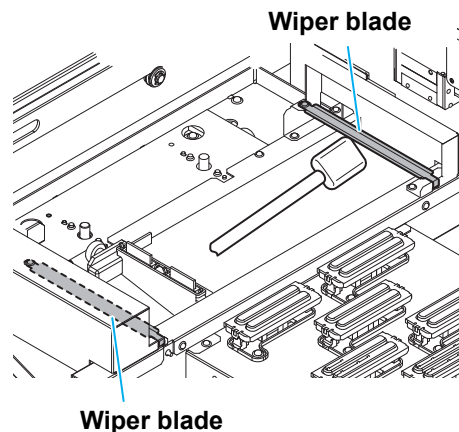
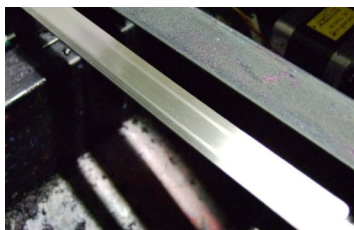
**11****Clean the cap rubber and cap rubber cover.**

- Wipe off the ink sticking to the cap rubber and cap rubber cover with a clean stick dipped in cleaning solution for maintenance. Wipe off so that cleaning solution for maintenance will not remain.

**Important!**

- Clean the wiper until it looks as shown in the photo on the right.
- Make sure that the cap rubber and mesh inside the cap have not come off after cleaning.

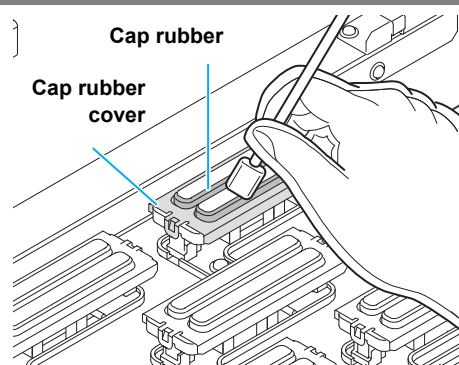
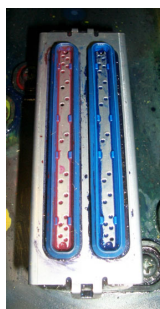
**12****Press the **ENTER** key after the cleaning.**

Close a cover  
COMPLETED [ENT]

**13****Close the right maintenance cover then press the **ENTER** key.**

- After its initial operation, the machine returns to step1.

**Performing the station maintenance without **MAINT.** key**

You can select station maintenance by using the **FUNCTION** key in the Local without pressing the **MAINT.** key.

Press the **FUNCTION** key in Local.

Press **▲** **▼** to select **[MAINTENANCE]**.

Press the **ENTER** key twice.

- It becomes the same condition as the **MAINT.** key is pressed from Local.

## Cleaning the wiper ink pan

Water-based ink does not flow easily. Ink dries, gets stuck, and accumulates. Use a rubber spatula or the like to frequently push the ink that piles up in the ink pan beneath the wiper towards the waste route.

**1** Press the **MAINT.** key in LOCAL.

CARRIAGE OUT [ENT]

**2** Press the **ENTER** key.

MOVE POSITION : STATION MAINT.

**3** Press **▲ ▼** to select [STATION MAINT.].

MOVE POSITION : STATION MAINT.

**4** Press the **ENTER** key.  
• The carriage moves onto the belt.

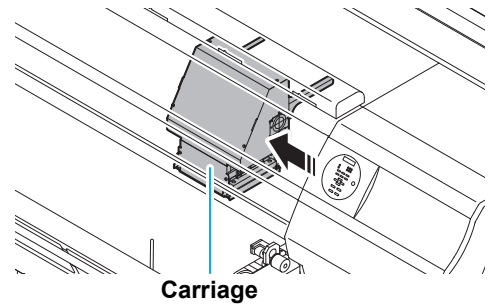

**5** Open the right maintenance cover.

- (1) Rotate the screws under the right maintenance cover (for three positions) to the left and remove them.
- (2) Hold the bottom of the right maintenance cover and pull it to the front.
- (3) While pulling the right maintenance cover downward, remove it.

- If the right maintenance cover is hard to remove, use the supplied screwdriver.

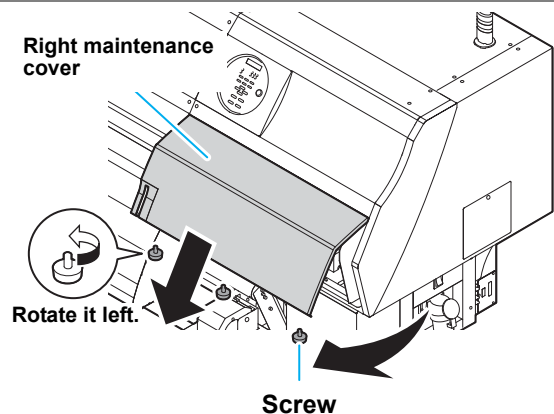

**6** Clean the wiper ink pan.

- Use a rubber spatula or the like to frequently push the ink that piles up in the ink pan Beneath the wiper towards the waste route.

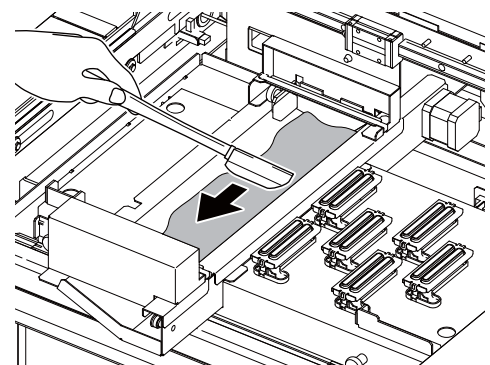

---

**7**

Press the **ENTER** key after the cleaning.

Close a cover  
COMPLETED [ENT]

---

**8**

Close the right maintenance cover then press the **ENTER** key.

- After its initial operation, the machine returns to step1.
-

## Washing the Ink Discharge Passage (DISWAY WASH)

Wash the ink discharge passage regularly to prevent the head nozzles from clogging due to ink coagulation inside the passage.

**1** Press the **MAINT.** key in LOCAL.

CARRIAGE OUT  
[ ENT ]

**2** Press **▲ ▼** to select [DISWAY WASH].

DISWAY WASH  
[ ENT ]

**3** Press the **ENTER** key.

- The carriage moves onto the belt.
- Dry suction operation is performed repeatedly until the washing work is completed.

DISWAY WASH  
COMPLETED (NEXT) [ ENT ]

**4** Open the right maintenance cover.

- (1) Rotate the screws under the right maintenance cover (for three positions) to the left and remove them.
- (2) Hold the bottom of the right maintenance cover and pull it to the front.
- (3) While pulling the right maintenance cover downward, remove it.

- If the right maintenance cover is hard to remove, use the supplied screwdriver.

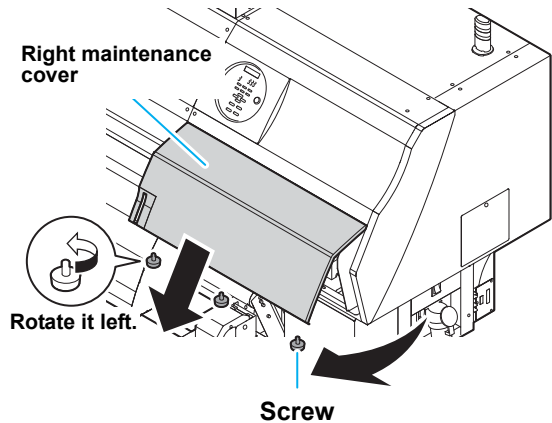

**5** Fill up the cap with cleaning solution for maintenance, using a dropper.

- Fill the cap with the cleaning solution just before the solution overflows from the cap.

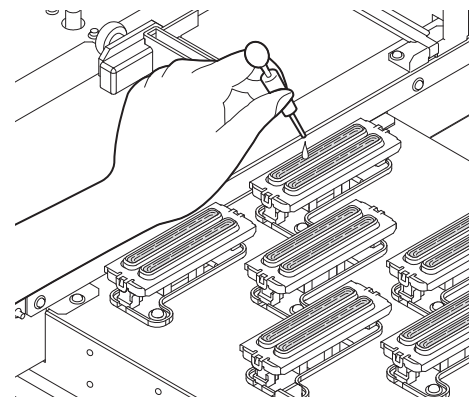

**6** Close the right maintenance cover and press the **ENTER** key.

- After the idle absorbing operation has been performed for 30 seconds, the screen returns to step2.

DISWAY WASH  
PLEASE WAIT

## When the Machine Is Not Used for a Long Time (CUSTODY WASH)

When the machine is not going to be used for a week or more, use the cleaning function for custody to clean the head nozzles and ink discharge passage. After this, keep the machine in custody.

Check the items on the right beforehand.

Is [INK END] displayed?

- The ink is absorbed when the nozzles are washed.
- At this time, if the state of "INK END" is detected, the nozzle washing operation cannot start.
- Replace the ink bottle with another from which the state of "INK END" is not detected.

1

Press the **MAINT.** key in LOCAL.

CARRIAGE OUT

[ ENT ]

2

Press **▲** **▼** to select [CUSTODY WASH].

CUSTODY WASH

[ ENT ]

3

Press the **ENTER** key.

- The carriage moves onto the belt.

WI PER CLEANING

COMPLETED (NEXT) [ ENT ]

**Important!**

- Until wiper/ bracket cleaning is completed, [COMPLETED (NEXT): ENT] is displayed on the screen. After the work up to the step 4 is completed, press the **ENTER** key. If you press the **ENTER** key before cleaning is completed, the machine moves to the next washing procedure.

4

Clean the wiper and the bracket.

- (1) Open the right maintenance cover then pull out it by holding projections at both ends of the wiper.
- (2) Clean the wiper and bracket with a clean stick dipped in cleaning solution for maintenance (ML003-Z-K1). Wipe off so that cleaning solution for maintenance will not remain.
- (3) Insert it in the original position by holding the projections at both ends of the wiper.

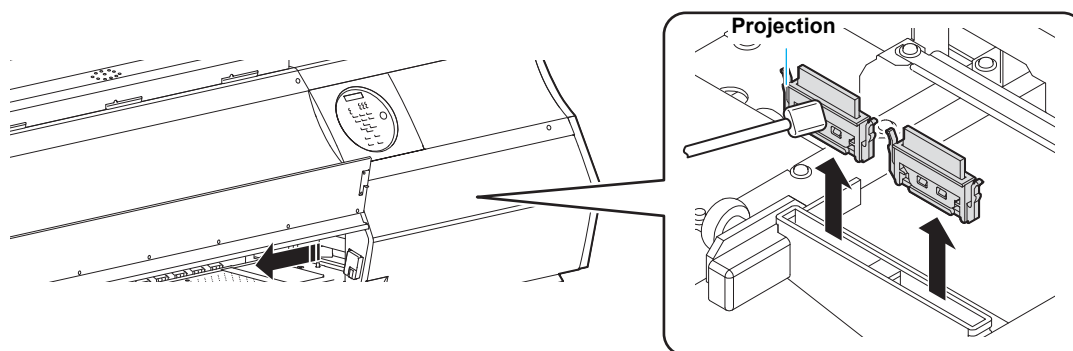



**5** Press the **ENTER** key.

- The carriage moves onto the belt.

CAP CLEANING  
COMPLETED (NEXT) [ENT]

**Important!**

- Until wiper cleaning is completed, [COMPLETED (NEXT): ENT] is displayed on the screen. After the work up to the step 6 is completed, press the **ENTER** key. If you press the **ENTER** key before cleaning is completed, the machine moves to the next washing procedure.

**6** Clean the cap rubber and cap rubber cover.

- Wipe off the ink sticking to the cap rubber and cap rubber cover with a clean stick dipped in cleaning solution for maintenance. Wipe off so that cleaning solution for maintenance will not remain.
- At this time, the discharge passage is cleaned automatically.

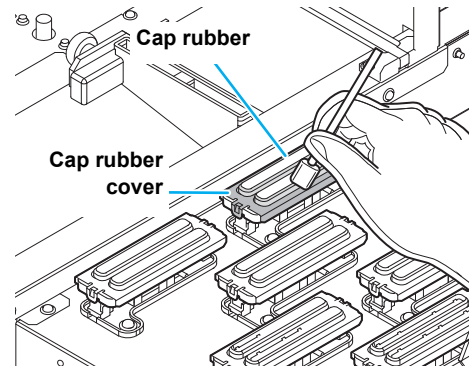

**7** Press the **ENTER** key.

**Important!**

- Until washing liquid is filled, [COMPLETED (NEXT): ENT] is displayed on the screen. After the work up to the Step 8 is completed and you close the front cover, press the **ENTER** key. If you press the **ENTER** key before washing liquid is filled, the carriage returns to the original position.

Fill the liquid.  
COMPLETED (NEXT) [ENT]

**8** Fill up the cap with cleaning solution for maintenance, using a dropper.

- Fill the cap with the cleaning solution just before the solution overflows from the cap.

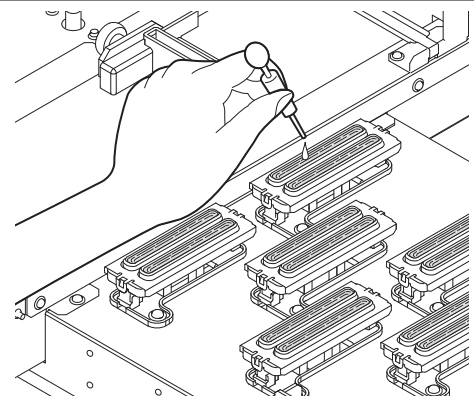

**9** Close the right maintenance cover and press the **ENTER** key.

LEAVING TIME  
= 1mi n

**10** Press **▲** **▼** to set the time for the cleaning solution to be left as it is.

- Set Value: 1 to 99 min (by the unit of 1 min)

LEAVING TIME  
= 2mi n

11

Press the **ENTER** key.

- The nozzles are washed.
- When the nozzles have been completely washed, the head moves onto the belt.

PLEASE WAIT  
00:00



\*\* CLEAMING \*\*  
PLEASE WAIT

12

Open the right maintenance cover.

13

Fill up the cap with cleaning solution for maintenance, using a dropper.

- Fill the cap with the cleaning solution just before the solution overflows from the cap.

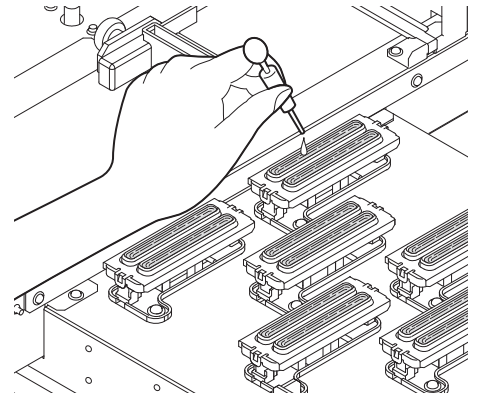

14

Close the right maintenance cover and press the **ENTER** key.

- After its initial operation, the machine returns to step2.

CUSTODY WASH  
PLEASE WAIT

# Cleaning the Head and the Area around It

Because the head employs a very precise mechanism, due care needs to be taken when it is cleaned. Using a clean stick, etc., rub off gelatinous ink or dust that may stick to the lower part of the slider and the area around the head. In doing so, never rub the nozzles of the head.

<b>Tools required for cleaning</b>	• Clean stick (SPC-0527)	• Gloves	• Goggles
------------------------------------	--------------------------	----------	-----------



- Be sure to wear the attached goggles and gloves when cleaning the area around the head. Otherwise, you may get ink in your eyes.
- If you get the ink on your skin or in your eyes, wash it away with plenty of water immediately.
- Clean the bottom of carriage every day so that it will not get dirt from inks or dusts. If you leave it dirty, dust and dry ink may be rubbed against the nozzle at wiping operation when performing head cleaning.
- When you clean the carriage bottom surface, fully be careful not to rub the nozzle surface.

**1** Press the **MAINT.** key in **LOCAL**. CARRIAGE OUT  
[ENT]

**2** Press the **ENTER** key. MOVE POSITION  
: STATION MAINT.

**3** Press **▲ ▼** to select **[HEAD MAINT.]**. MOVE POSITION  
: HEAD MAINT.

**4** Press the **ENTER** key.  
• Carriage will move to the left end of this device.

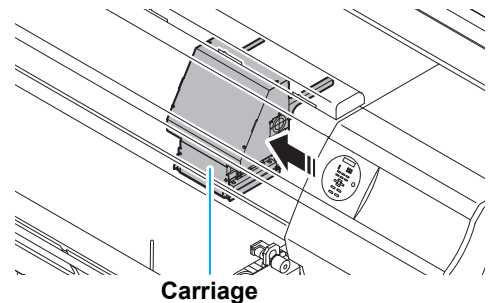

**5** **Open the left maintenance cover.**

- (1) Rotate the screws under the left maintenance cover (for three positions) to the left and remove them.
- (2) Hold the bottom of the left maintenance cover and pull it to the front.
- (3) While pulling the left maintenance cover downward, remove it.

• If the left maintenance cover is hard to remove, use the supplied screwdriver.

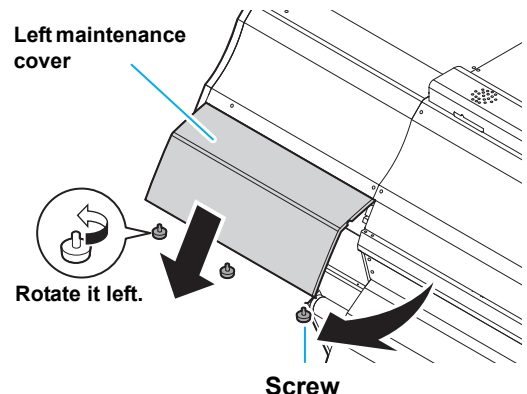

6

Soak the clean stick or the waste cloth in the maintenance cleaning liquid and wipe off an accumulated ink on the side of the head and on the bottom surface of the slider.

- Do not touch the nozzle surface, because the cleaning will be performed in the step 7.

Side surface of the head (shown in deep gray)

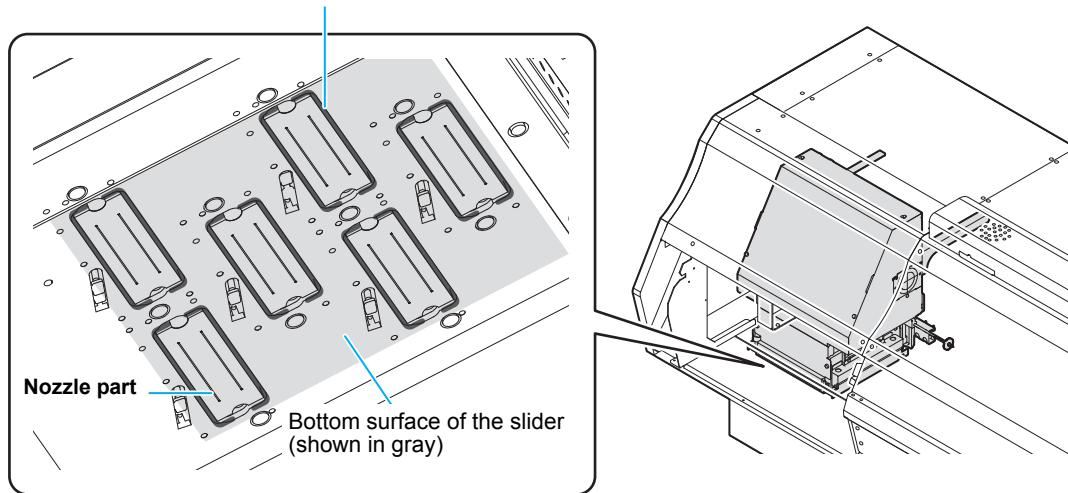

Important!

- Clean the wiper until it looks as shown in the photo on the right.

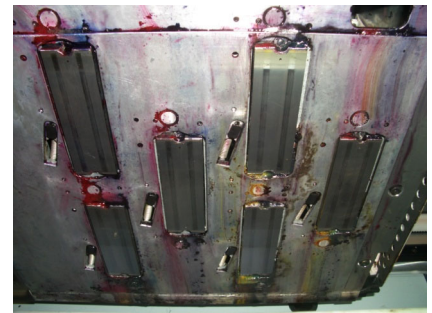

7

Soak the COTTON CIEGAL® in the maintenance cleaning liquid and wipe off the mark of the cap rubber attached on the nozzle surface from the rear side to the front side.

COTTON CIEGAL®



[Before cleaning]

[After cleaning]



Mark of the cap

Important!

- Immerse much enough so that maintenance liquid may drip from it.
- Do not wipe the nozzle surface with dry COTTON CIEGAL®.
- If COTTON CIEGAL® has fluffed, replace it.
- If ink solid adheres to COTTON CIEGAL®, change the surface to use for cleaning or replace it.

8

Press the **ENTER** key after the cleaning.

- Close the left maintenance cover then press the **ENTER** key.

Close a cover  
COMPLETED [ENT]

# When Nozzle Clogging Cannot Be Solved

When nozzle clogging cannot be solved even after the head cleaning (☞ P.2-33) has been done, perform the following two functions:

<b>NOZZLE WASH</b>	• Wash the head nozzle. (☞ P.4-17)
<b>NOZZLE RECOVERY</b>	• Alternative nozzles for printing, when nozzles missing can not be improved. (☞ P.4-19)

## Washing of Head nozzle

Perform cleaning of the nozzles in the heads to prevent them being clogged with coagulated ink.

<b>Check the items on the right beforehand.</b>	<p><b>Is [INK END] displayed?</b></p> <ul style="list-style-type: none"> <li>• The ink is absorbed when the nozzles are washed. At this time, if the state of "INK END" is detected, the nozzle washing operation cannot start.</li> <li>• Replace the ink bottle with new one for which ink end has not been detected.</li> </ul>
---	--

**1** Press the **MAINT.** key in LOCAL.

CARRIAGE OUT [ENT]

**2** Press **▲ ▼** to select **[NOZZLE WASH]**.

NOZZLE WASH [ENT]

**3** Press the **ENTER** key.

- The carriage moves onto the belt.

WIPER CLEANING COMPLETED (NEXT) [ENT]

**Important!** • Until wiper cleaning is completed, [COMPLETED (NEXT): ENT] is displayed on the screen. After the work up to the step 4 is completed, press the **ENTER** key. If you press the **ENTER** key before cleaning is completed, the machine moves to the next washing procedure.

**4** Clean the wiper and the bracket.

- (1) Open the right maintenance cover then pull out it by holding projections at both ends of the wiper.
- (2) Clean the wiper and bracket with a clean stick dipped in cleaning solution for maintenance. (ML003-Z-K1) Wipe off so that cleaning solution for maintenance will not remain.
- (3) Insert it in the original position by holding the projections at both ends of the wiper.

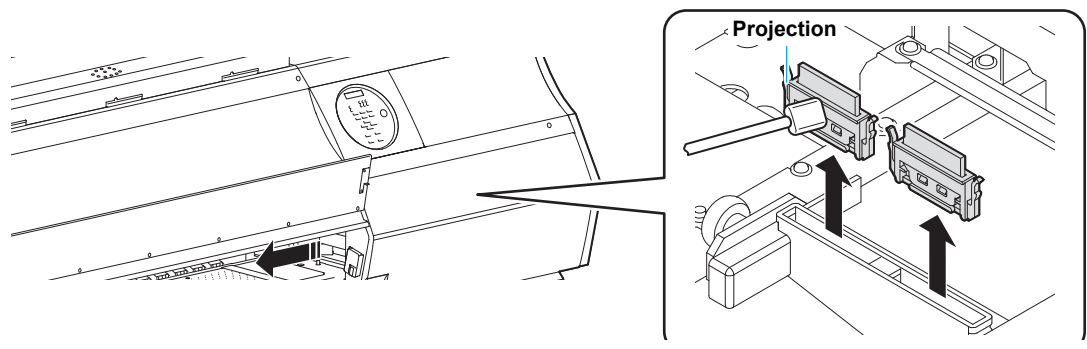

**5** Press the **ENTER** key.

CAP CLEANING COMPLETED (NEXT) [ENT]

**Important!** • Until wiper cleaning is completed, [COMPLETED (NEXT): ENT] is displayed on the screen. After the work up to the step 6 is completed, press the **ENTER** key. If you press the **ENTER** key before cleaning is completed, the machine moves to the next washing procedure.

**6****Clean the cap rubber and cap rubber cover.**

- Wipe off the ink sticking to the cap rubber and cap rubber cover with a clean stick dipped in cleaning solution for maintenance. Wipe off so that cleaning solution for maintenance will not remain.
- At this time, the discharge passage is cleaned automatically.

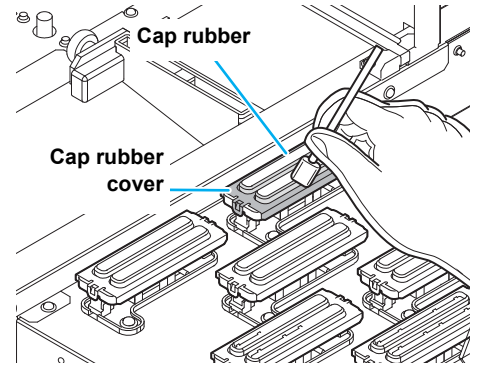
**7****Press the **ENTER** key.**

Fill the liquid.  
COMPLETED(NEXT) [ENT]

**Important!**

- Until washing liquid is filled, [COMPLETED (NEXT): ENT] is displayed on the screen. After the work up to the Step 8 is completed and you close the front cover, press the **ENTER** key. If you press the **ENTER** key before washing liquid is filled, the carriage returns to the original position.

**8****Fill up the cap with cleaning solution for maintenance, using a dropper.**

- Fill the cap with the cleaning solution just before the solution overflows from the cap.

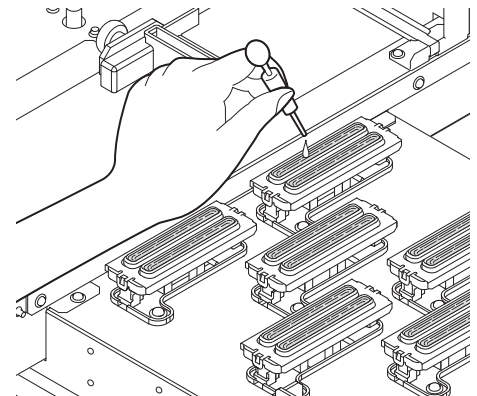
**9****Close the right maintenance cover then press the **ENTER** key.**

LEAVING TIME  
= 1min

**10****Press **▲** **▼** to set the time for the cleaning solution to be left as it is.**

LEAVING TIME  
= 2min

- Set value : 1 to 15 minutes (Unit: minute)

**11****Press the **ENTER** key.**

- The cleaning solution filled in the cap is absorbed.
- The screen on the right is displayed only for the duration set in the step 10.
- It returns to the step2 after the duration.

PLEASE WAIT  
00:00



\*\* CLEAMING \*\*  
PLEASE WAIT

**Important!**

- When nozzle missing is not cleared even after this washing is carried out several times, contact the distributor in your region or our service office.

## Alternative nozzles for printing, when nozzles missing can not be improved

**NOZZLE RECOVERY:** When nozzles missing can not be improved at specific points, other good nozzles can be used as alternatives for printing.

The head of this machine consists as the right figure. You can set the recovery by specifying the nozzle line each for the H1-2 (Head 1-2), the H3-4 (Head 3-4) and the H5-6 (Head 5-6).



### About nozzle line

- This machine is equipped with four nozzle lines (Line A, Line B, Line C and Line D) for one head.

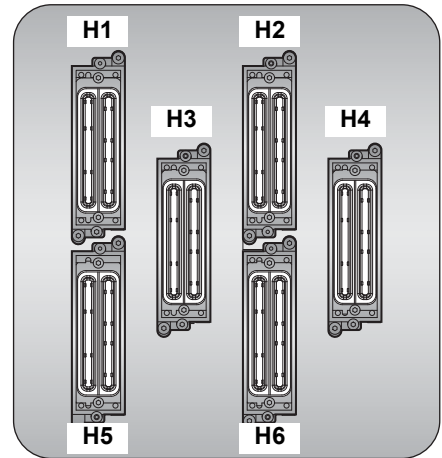
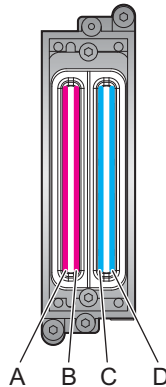

1

Select **[NOZZLE RECOVERY]** of the maintenance menu.

- Press the **[FUNCTION]** key in LOCAL.
- Press **[▲]** **[▼]** to select **[MAINTENANCE]** and press the **[ENTER]** key.
- Press **[▲]** **[▼]** to select **[NOZZLE RECOVERY]**.
- Press the **[ENTER]** key.

2

Press **[▲]** **[▼]** to select **[PRINT]** and press the **[ENTER]** key.

NOZZLE RECOVERY  
: PRINT



SELECT HEAD  
: H1 - 2

3

Press **[▲]** **[▼]** to select the head (H1-2/ H3-4/ H5-6) for which you perform nozzle recovery.

SELECT HEAD  
: H3 - 4

4

Press the **[ENTER]** key twice.

- The nozzle pattern of selected unit is printed.
- When you select "ENTRY" in the Step 2, the machine moves to the nozzle line selection procedures (Step 5) without printing a nozzle pattern.

\*\* PRINTING \*\*  
PLEASE WAIT

Nozzle pattern when selecting H1-2

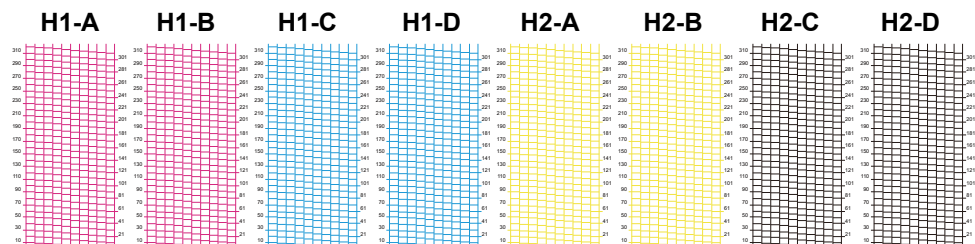

4

**5**

Press **▲** **▼** to select the Nozzle line that needs **NOZZLE RECOVERY** and press the **ENTER** key.

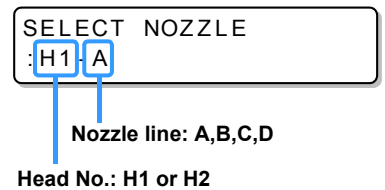
**6**

Register the Nozzle number that needs **NOZZLE RECOVERY** and press the **ENTER** key.

(1)

Select the registration number from 1 to 10 by pressing **▲** **▼** and press the **ENTER** key.

(2) Register the nozzle number that needs recovery by pressing **▲** **▼** and press the **ENTER** key.

- If the registered nozzle cannot be recovered, the screen of the Step 3 in P.4-21 "Check the print condition for which nozzle recovery cannot be performed" is displayed.

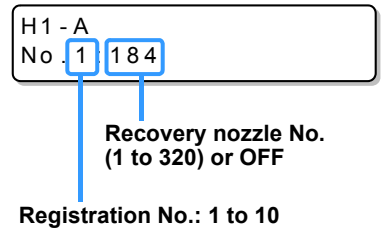

#### Example of nozzle to be recovered

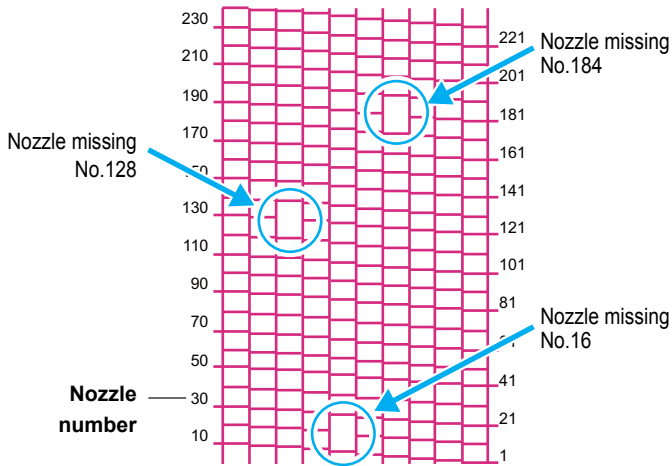

Registration number	Recovery Nozzle No.	State
1	16	Target for nozzle recovery
2	128	Target for nozzle recovery
3	184	Target for nozzle recovery
4	OFF	No registration
5	OFF	No registration

**7**

Press the **END** key several times to end the setting.

**Important!**

- Up to 10 nozzles can be registered per 1 nozzle line.
- Even if you use this function, time required for drawing does not change.
- In the minimum number of pass of the drawing mode, the **NOZZLE RECOVERY** function is not available.
- In the minimum number of pass for double speed mode and normal speed mode, **NOZZLE RECOVERY** function is not available.
- Even if you register the **NOZZLE RECOVERY**, the pattern of test print etc. is not recovered.



## Check the print condition for which nozzle recovery cannot be performed

Depending on the registered nozzle, there is a mode on which recovery is not reflected. Check the print condition for which recovery cannot be performed.



- When there are many registered nozzles, it takes much time to display the checked result.

# 1

Select [NOZZLE RECOVERY] of the maintenance menu.

- (1) Press the **FUNCTION** key in LOCAL.
- (2) Press **▲** **▼** to select [MAINTENANCE] and press the **ENTER** key.
- (3) Press **▲** **▼** to select [NOZZLE RECOVERY].
- (4) Press the **ENTER** key.

# 2

Press **▲** **▼** to select [CHECK].

```
NOZZLE RECOVERY
:CHECK
```

# 3

Press the **ENTER** key.

- The mode for which nozzle recovery is invalid is displayed.
- If there is no mode for which nozzle recovery is invalid, "NONE" is displayed.

```
UNRECOVERABLE COND.
: 600x 900 6p H
```

Resolution

Scanning speed

Number of passes

# 4

Press **END** the key several times to end the setting.

## Clear the set value

# 1

Select [NOZZLE RECOVERY] of the maintenance menu.

- (1) Press the **FUNCTION** key in LOCAL.
- (2) Press **▲** **▼** to select [MAINTENANCE] and press the **ENTER** key.
- (3) Press **▲** **▼** to select [NOZZLE RECOVERY].
- (4) Press the **ENTER** key.

# 2

Press **▲** **▼** to select [RESET] and press the **ENTER** key.

NOZZLE RECOVERY  
: RESET



SELECT HEAD  
: H1 - 2

# 3

Press **▲** **▼** to select the head (H1-2/ H3-4/ H5-6) for which you reset nozzle recovery.

SELECT HEAD  
: H3 - 4

# 4

Press the **ENTER** key.

SELECT RESET NOZZLE  
: H1 - A

# 5

Press **▲** **▼** to select the Nozzle line that needs reset the setting value and press the **ENTER** key.

SELECT RESET NOZZLE  
: H1 - A



H1 - A RESET?  
EXECUTE [ENT]

# 6

Press the **ENTER** key.

# 7

Press the **END** key several times to end the setting.

# Automatic Maintenance Function

To use this machine comfortably, you can set various maintenances to be performed automatically.

Here, set performing intervals of various automatic maintenances.

You can prevent troubles such as ink clogging by performing automatic maintenance periodically (automatic maintenance function).

For the auto maintenance functions, the following items can be set:



- When you perform maintenance manually, after manual maintenance is completed and when time set with the automatic maintenance function has passed, maintenance starts automatically.

Function name	Descriptions
REFRESH	The interval between each refreshing operation is set.
CLEANING	The interval between each cleaning operation is set.



- During the right message is displayed, the operation set in the auto maintenance function is not carried out. Perform the operations of P.4-27 if required.
- When the power button on the front of the machine is turned off, check the waste ink tank.

<LOCAL>  
Waste ink full

## Setting the Refreshing Intervals

The interval between each operation of ejecting a small amount of ink from the nozzles to prevent nozzle clogging is set.

1

Select **[AUTO MAINT.]** of the maintenance menu.

- (1) Press the **[FUNCTION]** key in LOCAL.
- (2) Press **[▲]** **[▼]** to select **[MAINTENANCE]** and press the **[ENTER]** key.
- (3) Press **[▲]** **[▼]** to select **[AUTO MAINT.]**.

2

Press the **[ENTER]** key.

AUTO MAINT.  
REFRESH [ENT]

3

Press the **[ENTER]** key.

REFRESH  
: Lv. 1

4

Press **[▲]** **[▼]** to set the refreshing interval.

- Set value : OFF, Lv.1, Lv.2, Lv.3
- As the LEVEL increases, the interval between each operation gets shorter.

REFRESH .  
: Lv. 1

5

Press the **[ENTER]** key.

AUTO MAINT.  
REFRESH [ENT]

6

Press **[END]** the key several times to end the setting.

4

Routine Maintenance

## Setting the Cleaning Intervals

The cleaning type and the interval between each cleaning operation are set.

# 1

Select [AUTO MAINT.] of the maintenance menu.

- (1) Press the **FUNCTION** key in LOCAL.
- (2) Press **▲** **▼** to select [MAINTENANCE] and press the **ENTER** key.
- (3) Press **▲** **▼** to select [AUTO MAINT.].
- (4) Press the **ENTER** key.

# 2

Press **▲** **▼** to select [CLEANING].

AUTO MAINT .  
CLEANING [ENT]

# 3

Press the **ENTER** key.

CLEANING  
: Lv . 1

# 4

Press **▲** **▼** to set the interval between each cleaning operation.

CLEANING  
: Lv . 1

- Set value : OFF, Lv.1, Lv.2, Lv.3
- As the LEVEL increases, the interval between each operation gets shorter.

# 5

Press the **ENTER** key.

- When you set other than "OFF" in the Step 4, the cleaning type selection screen is displayed.

TYPE  
: NORMAL

# 6

Press **▲** **▼** to select a cleaning type.

- Set value : NORMAL, SOFT, HARD

TYPE  
: SOFT

# 7

Press the **ENTER** key.

AUTO MAINT .  
CLEANING [ENT]

# 8

Press the **END** key several times to end the setting.

# Cleaning Y motor

When the warning message [Y motor cleaning] is displayed, clean the Y motor with the procedures below:

## 1 Turn off the power supply, and open the Y-motor maintenance cover.

- Remove the screw of the Y-motor maintenance cover, and open the cover.

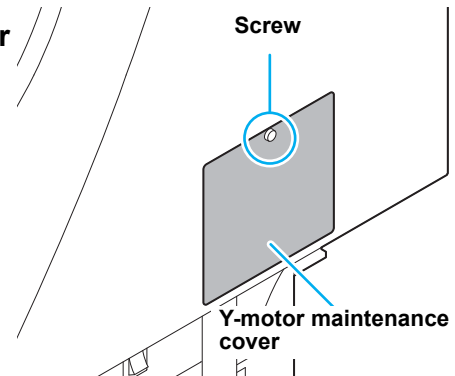

## 2 Open the cover for absorbing abrasion powder, and absorb abrasion powder accumulating in the hole for absorbing abrasion powder with a vacuum.

- Using a flat-blade screwdriver, open the cover.

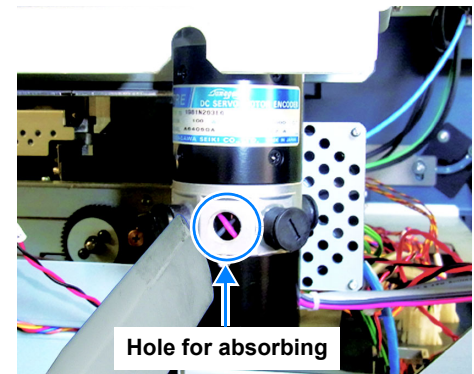

## 3 Return the cover for absorbing abrasion powder to the original status, and turn on the power supply.

- Warning message [Y motor cleaning] is displayed on the screen.

## 4 Press the **MAINT.** key and clear the warning message.

- The machine returns to LOCAL.

# Replacing consumables

## Replacing the wiper

The wiper is consumable. When the display indicates that it is necessary to replace the wiper, immediately replace the wiper with a new one. Also, wipe ink sticking to the lower surface of the slider off.

<LOCAL>  
Replace a WIPER[MNT]

**Important!**

- A cleaning wiper (SPA-0193) is an option. Buy one through the dealer in your region or at our service office.

**1**

When the message is displayed, press the **MAINT.** key.

REPLACE WIPER  
EXECUTE [ENT]

**2**

Press the **ENTER** key.

- The carriage moves onto the belt.

REPLACE WIPER  
COMPLETED [ENT]

**Important!**

- Until the replacement work is completed, [COMPLETED: ent] is displayed on the screen. After the work up to the Step 3 is completed and you close the right maintenance cover, press the **ENTER** key.

**3**

Open the right maintenance cover then remove the wiper.

- Pull out the wiper by holding the protrusions at its both ends.

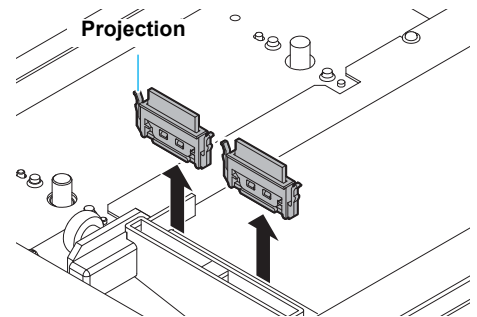

**4**

Insert a new wiper.

- Insert a new wiper by holding its both ends.

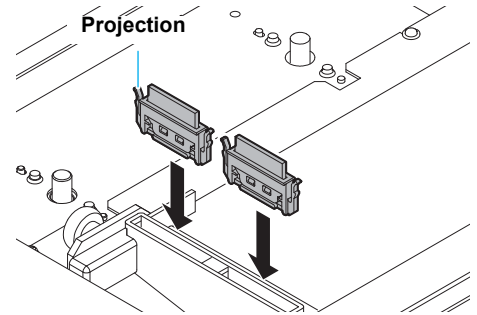

**5**

Close the right maintenance cover and press the **ENTER** key.

- After its initial operation, the machine returns to LOCAL.

\*Being Initialized\*  
PLEASE WAIT

## If a Waste Ink Tank Confirmation Message Appears

Ink used in head cleaning, etc. is stored in the waste ink tank on the lower right side of the machine. The sensor monitors the discharged amount of ink in this machine. When that reaches a specified amount, the machine displays a confirmation message. (When this message is displayed, consider the replacement of the waste ink tank.)

### Confirmation Message in LOCAL

**1** The message on the right is displayed.

<LOCAL>  
Waste ink near full

or

<LOCAL>  
Waste ink full

or

<LOCAL>  
Waste ink tank none

**2** Check the state of the waste ink tank

### Replace the waste ink tank with another

**1** Open the waste ink tank cover.

- Remove the screw attaching to the waste ink tank cover and open the cover to the front.

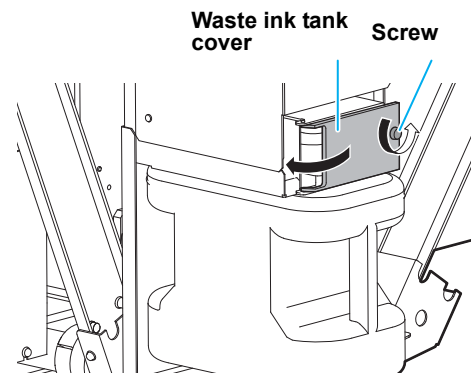

**2** Lift the waste ink tank a little.

- Lift the waste ink tank up to the position where it does not hit the stopper.

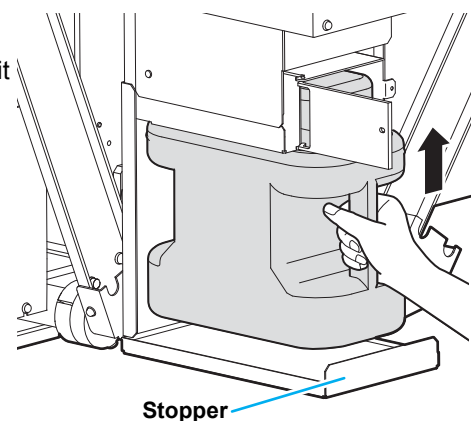

### 3

#### Take out the waste ink tank.

- (1) Hold the handle of the waste ink tank and pull it out to the front.
- (2) Raise the waste ink tank and take it out.

- Put a cap on the waste ink tank removed.

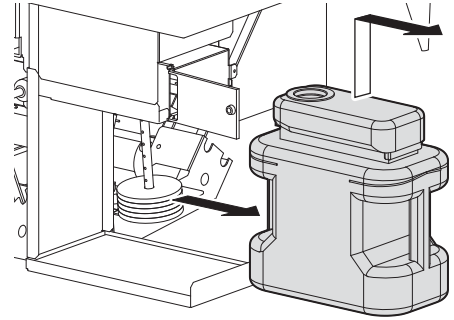
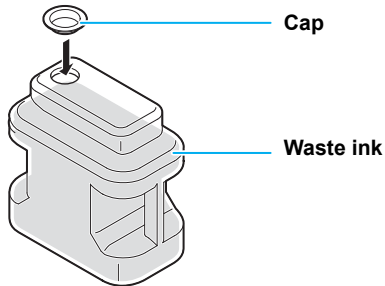

### 4

#### Replace the waste ink tank.

- (1) Prepare a new waste ink tank (SPC-0197).
- (2) Hold the handle of the waste ink tank and insert it along the rail.
- (3) Raise the waste ink tank.



- Waste ink is equivalent to waste oil or industrial waste. Request an industrial waste disposal company for disposal of waste ink.

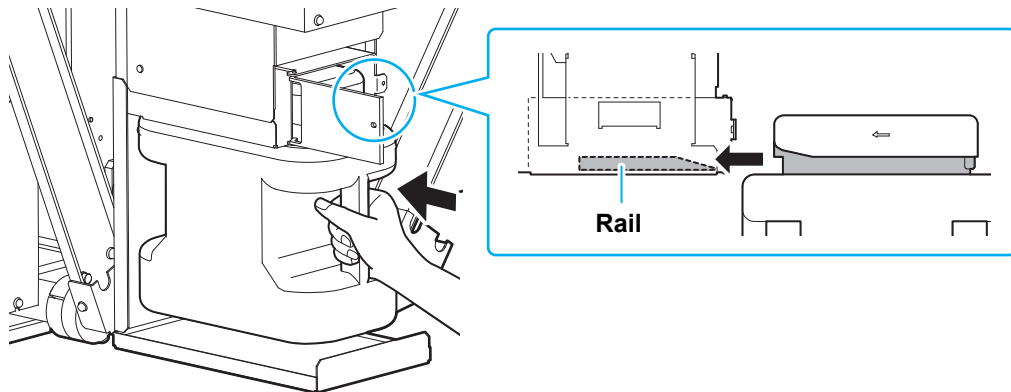

### 5

#### Close the waste ink tank cover.

- When the machine recognizes the new waste ink tank, the warning message is released.

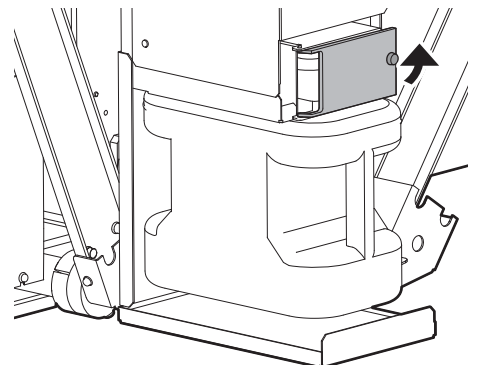



# Cleaning the washing unit

Clean the belt washing unit regularly (about once a month) to make sure that there is no ink or lint on the belt surface.

- 1 Turn the levers on both sides of the belt washing unit to unlock.

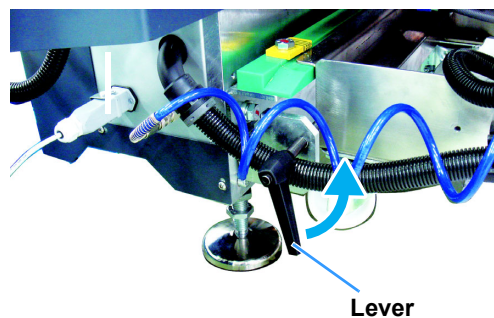

- 2 Pull out the belt washing unit forward.

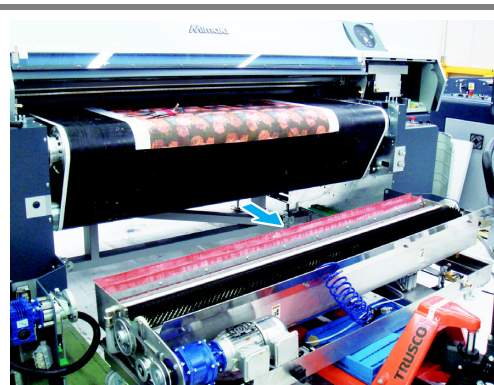

- 3 Clean the nozzles of the shower part with a cotton swab.

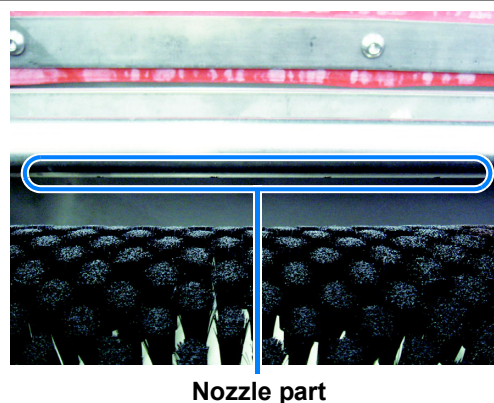

- Important!** • Treat drainage from the belt washing unit properly in compliance with regulation in the local area.

# Cleaning of peeling sensor

To prevent the peeling sensor from the operation mistake due to blot, clean the peeling sensor periodically (about once a week).

**Important!**

- The peeling sensor may be dirty because of ink mist generated at printing and steam generated when the fabric is evaporated.

In addition, perform cleaning in the following status.

- The alarm beeps without the fabric being peeled.
- The alarm beeps even when the fabric is not taken up on the belt.

**1**

Wipe the reflector with a cleaning cloth (like BEMCOT or the like) immersed in the washing liquid.



**2**

Wipe the reflector wiped in the Step 1 with a dry cleaning cloth (like BEMCOT or the like).

**3**

Wipe the two lens of the peeling sensor with a cotton swab immersed in the washing liquid.

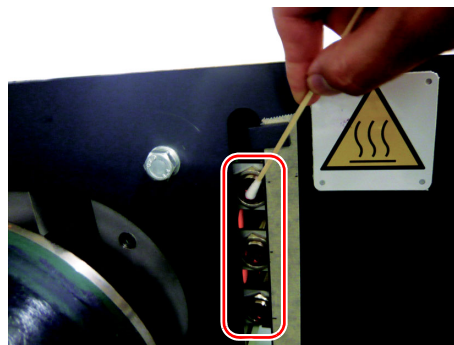

**4**

Wipe the lens wiped in the Step 3 with a dry cotton swab.

# When power of adhesive weakened

When power of adhesive weakened, you must recoat it. Though adhesive was coated on this machine before shipment, when the power of it weakened due to ink, lint, dust, etc., you must recoat it. To peel adhesive coated on before shipment, use the remover attached to this machine. (As adhesive is special one, you cannot peel it with kerosene nor diesel oil.)

The following are the procedures when using Mimaki's genuine adhesive (Polixresin SX).

- **Peel old adhesive**.....Peel adhesive whose power weakened.
- **Coat new adhesive** .....Coat adhesive newly.

## Rough standard of recoating adhesive

In the following cases, it is time to recoat adhesive:

- Fixation has float when the printed fabric comes out from the front cover
- When the strength of right of fixation is different from that of left
- When drops of water remain on the upper surface of the belt because the belt surface became uneven due to adhesive being peeled partly etc. and washing liquid could not be wiped with the cleaning unit wiper
- On the peeling roller, as the take-up device cannot operate because the media is peeled due to its own weight, when the media may fall on the floor

### ● In case that Mimaki's genuine adhesive, Polixresin SX , is applied

In case that 1 liter of our genuine adhesive, Polixresin SX, is applied, the usable print length is approximately between 2500mm and 3000mm.

If the adhesive power gets weaker, turn the adjustment dial of rear side of the media feeding part, and lower the air pressure to 0 bar side.

Then, pressure of the pressure roller increases. (MAX: 0 bar)

Also, in case that adhesive power is too strong, turn the adjustment dial, and increase the air pressure.

Then, pressure of the pressure roller decreases.

#### Important!

- Mimaki's genuine adhesive is solvent pressure sensitive adhesive. Be sure to wear the protection mask for organic solvent, the goggle and the gloves to recoat adhesive.
- When recoating adhesive, keep fire away and be sure to turn OFF the belt heater and the main heater. Also, be sure to provide adequate ventilation. In addition, be sure to start the work after one hour and more have passed since the heater was turned OFF.
- When recoating adhesive, be sure to use the chemical-proof (kerosene-proof) gloves.
- When you recoat adhesive in the room with poor ventilation or hermetically closed room, be sure to set up the ventilation equipment.
- When using adhesive, be sure to comply with Ordinance on the Prevention of Organic Solvent Poisoning. In addition, when recoating adhesive, be sure to perform the work under the supervision of a person who completed the training session of organic solvent work chief or a work chief of organic solvent.
- If the fabric loosened before using, and if float or surface waviness occurs when you attach it on the feeding belt (when it passes the pressure roller), adhesive is not a cause. In addition, the fabric cannot be used. (☞ P.1-23"Media")

## Be sure to check before recoating adhesive

The power of adhesive on the feeding belt differs depending on the type/the used time of adhesive, media type/ thickness, temperature or humidity, etc.

Depending on the type of anti-wrinkling agent, or other conditions, the set value of the pressure roller of the media feeding part is required to be adjusted.



- The feeding belt is made of polyurethane. Adhesive using solvent expanding polyurethane cannot be used. Ask the adhesive manufacturer whether adhesive you have can be used.



### Notes when recoating adhesive

- The worker handling adhesive shall wear the attached antistatic wrist strap to perform the work.
- When recoating adhesive, keep fire away and be sure to turn OFF the belt heater and the main heater. Also, be sure to provide adequate ventilation. In addition, be sure to start the work after one hour and more have passed since the heater was turned OFF.
- Be sure to provide adequate ventilation when recoating adhesive.
- If the anti-wrinkling agent or remover is accidentally dripped on the outside of the belt right and the left, wipe off the agent or remover being dripped before the work.

## Adhesive type

Select adhesive to be coated newly depending on the using environment or the usage.

Type	Good point	Bad point
Solvent type adhesive (recommended by our company)	(1) Has long life. (2) Can be dehydrated and cured in a short period of time until it becomes usable after coating.	(1) As organic solvent is used, preventing measure against toxication and measure against fire are required. (2) When peeling adhesive, organic solvent is required.
Aqueous-emulsion type adhesive	(1) You can dilute adhesive with water or alcohol. (2) There is no fear of organic solvent toxication.	(1) Life is shorter. (2) Cannot be dehydrated and cured in a short time after coating.
Spray type adhesive	(1) Time to dehydrate and cure after coating is not required.	(1) As life is extremely short, it can be used only on a temporary basis.

## Set adhesive power

You can change adhesive power by adjusting the pressure of the pressure roller.  
Adjust adhesive power to make the status of this machine as below:

### ● Rough standard for setting adhesive power

- (1) No lift shall be found on the media and the media edges within the carriage operating area at printing.
- (2) Media shall be fixed on the belt firmly until take-up starts at printing, and once take-up starts, the belt can be peeled off from the media smoothly.

**1** Set the media (👉 P.2-11)

**2** Make the belt heater "ON". (👉 P.2-10)

**3** Start printing. (👉 P.2-38)

**4** Check the adhering status of the belt to the media and adjust the pressure of the pressure roller.

- When increasing the pressure of pressure roller:  
Rotate the adjusting dial to the right to lower the value of the pressure indicator.



#### When media floats in the carriage operation area

- Increase the pressure of the pressure roller.
- When media is apart from the belt before take-up starts**

- Increase the pressure of the pressure roller.
- When media is not peeled off from the belt smoothly even after take-up starts**

- Decrease the pressure of the pressure roller.



- Do not make the value of the pressure indicator 2bar and more.

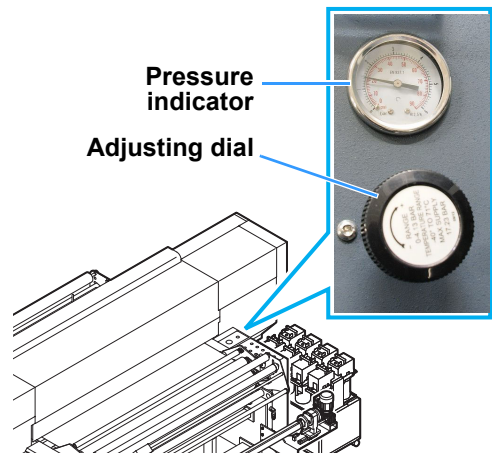

**Important!**

- If adhesive power cannot be improved even if you adjusted the pressure roller, adhesive has come to the end of its life. Perform the works from the next page to peel it off and recoat new adhesive.

## Peel weakened adhesive

To peel adhesive, the items below are required:

**Important!**

- To peel adhesive coated on before shipment, use the remover attached to this machine. As adhesive is special one, you cannot peel it with kerosene nor diesel oil.



### Notes when removing adhesive

- The worker handling remover shall wear the attached antistatic wrist strap to perform the work.
- Remover, heating oil, gas oil and ethanol are volatile hazardous objects. If you cannot use it all, put a lid on it and store in a cold dark place for storing hazardous objects.
- When removing adhesive, keep fire away and be sure to turn OFF the belt heater and the main heater. In addition, be sure to start the work after one hour and more have passed since the heater was turned OFF.
- Be sure to provide adequate ventilation when removing adhesive.

Item to be used	Item to be prepared
Doctor Gloves Plastic coma (attached to this machine) Remover	Waste cloth About one liter of kerosene or diesel oil About one liter of ethanol Cloth of about 2m x 2m Resin board of A4 size (thickness of about 1.0 to 3.0mm without sharp edges). Required not be swollen by ethanol or remover (Ex. material: PVC, PP).

**1**

**Set the doctor on the doctor support as the figure.**

**Important!**

- The doctor is very heavy. When carrying it or setting it on the doctor support, be sure to perform the work with two and more persons.



The cog of the doctor shall be in the direction in the photo seen from the left side surface.



**2**

**Adjust the hexagonal nuts under the doctor so that doctor comes to the lowest position, evenly touching the belt.**

**Important!**

- Be careful not to gap between the doctor and the belt. If there is a gap, remover may leak from the gap and may stain other parts.

**3**

**Fix the round shape nut of the adjustment screw part with your hand to fix the doctor.**

**4** Set it to the “SERVICE” screen by pressing [SERVICE] on the operation touch panel.

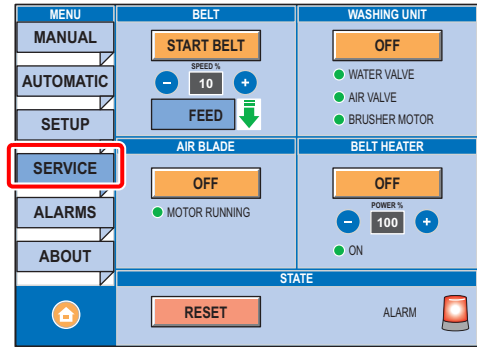

**5** Adjust to 10% by pressing the [-][+] key of “BELT”.

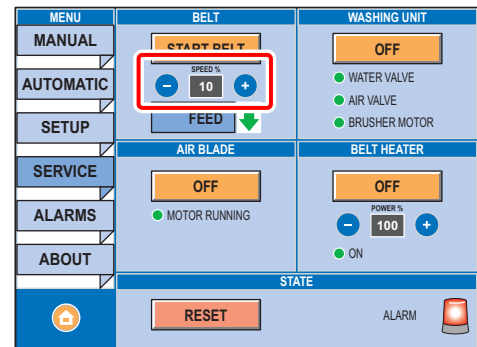

**6** First check that there is not the fabric or other object on the feeding belt, and then press the [START] to operate the belt.

**Important!**

- Confirm that “BELT HEATER” is [OFF] (in orange).

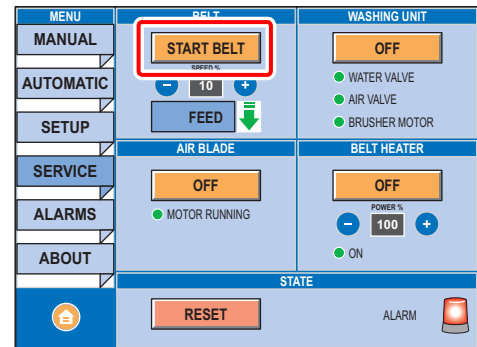
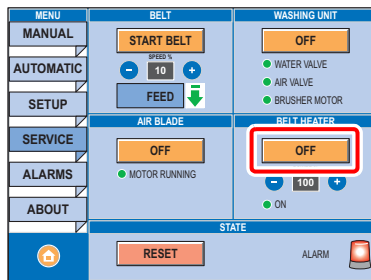

**7** Set the cloth on the side for applying kerosene (diesel oil) of the doctor to immerse kerosene (diesel oil) evenly.



---

**8**

**Pour remover on the belt so that it goes through the cloth.**

**Important!**

- Pour remover so that the drop does not drip off on the floor surface while the belt goes round once. If remover may adhere to other parts such as washing unit etc., it may adhere to adhesive again and cause the fixation fault.
- Be careful not to accrete kerosene (diesel oil) on the belt encoder roller in the right side of this machine (front and rear, total 2 positions).
- For the attached remover as standard, the used amount is about 5 liters. For Polix resin SX, kerosene (diesel oil) shall be about one liter as the rough standard.
- If remover drops from the belt, wipe it off completely with a waste cloth etc. Discard a waste cloth with remover perfused after dehydrating it.
- If remover dropped on the belt heater or the main heater, immediately turn OFF the power supply and contact a distributor in your district or our office to call for service.



---

**9**

**Rotate the belt until adhesive becomes soft and gelled.**

---

**10**

**Remove the doctor and wipe off adhesive on the doctor with the waste cloth immersed in remover.**

- This is cleaning to coat adhesive. Perform this before peeled adhesive cures again.



---

**11**

**Using the prepared resin board, peel off adhesive from the belt.**





**12**

After peeling off adhesive as much as possible with the resin board, remove the remaining adhesive on the belt surface with ethanol and the waste cloth.



**Important!**

- After the work above is completed, recheck whether there is any adhesive left not being peeled or large dust. If adhesive is newly coated with any adhesive left on the belt surface, concavity and convexity are generated on that part and it may influence on printing result.
- After the belt surface is dehydrated, coat new adhesive. (next page)
- Perfuse gelled liquid including peeled remover onto a waste cloth etc. and discard after dehydrating it.

## Coat new adhesive

To coat adhesive, the items below are required:

Item to be used	Item to be prepared
Doctor Gloves Plastic coma (attached to this machine)	Adhesive (Polixresin SX 1000cc, sold separately) Small amount of kerosene or diesel oil (to remove adhesive on the doctor) Waste cloth A small amount of neutral detergent diluted with water (atomizer)



### Notes when coating adhesive

- The worker handling adhesive shall wear the attached antistatic wrist strap to perform the work.
- When coating adhesive, keep fire away and be sure to turn OFF the belt heater and the main heater. In addition, be sure to start the work after one hour and more have passed since the heater was turned OFF.
- Adhesive, heating oil and gas oil are volatile hazardous objects. If you cannot use it all, put a lid on it and store in a cold dark place for storing hazardous objects.
- Be sure to provide adequate ventilation when coating adhesive. If you coat adhesive in a place with poor ventilation or in a closed place, be sure to install a ventilation device.



- Mimaki's genuine adhesive is solvent pressure sensitive adhesive. Be sure to wear the protection mask for organic solvent, the goggle and the gloves to recoat adhesive.
- When recoating adhesive, be sure to use the chemical-proof (kerosene-proof) gloves.
- When you recoat adhesive in the room with poor ventilation or hermetically closed room, be sure to set up the ventilation equipment.
- When using adhesive, be sure to comply with Ordinance on the Prevention of Organic Solvent Poisoning. In addition, when recoating adhesive, be sure to perform the work under the supervision of a person who completed the training session of organic solvent work chief or a work chief of organic solvent.
- When using adhesive commercially available, be sure to check compatibility between its solvent component and the belt material of this machine. If you wish to use it, contact a distributor in your district or our office.
- When overcoating adhesive (coating new adhesive on old adhesive), coating may not be performed finely due to concavity/convexity, dust, lint, etc. of the old adhesive surface.
- Be careful not to accrete adhesive around touching area of the belt encoder roller in the right side of this machine (front and rear, total 2 positions). Otherwise, the machine may not operate normally.

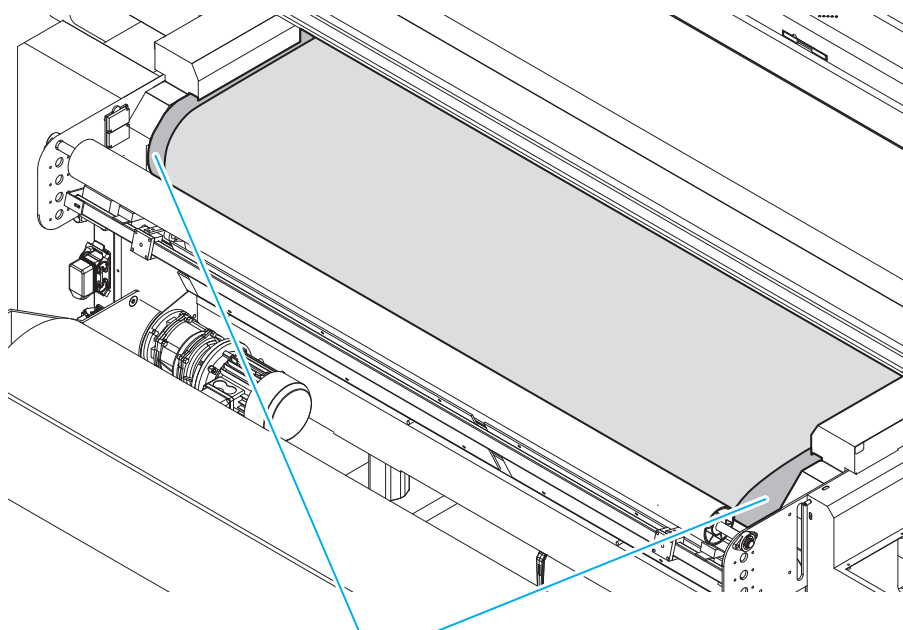

**Area to avoid applying the adhesive**

# 1

## Paste adhesive tape (with smooth-surface) on the belt front surface.

- Paste adhesive tape on the position as indicated in the figure (from both edges for right and left of the belt).

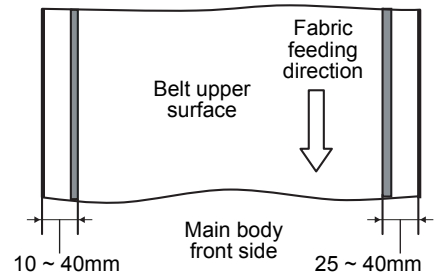
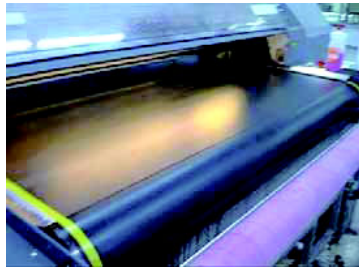

**Important!**

- Use elasticized adhesive tape such as vinyl tape.
- Check the chemistry of adhesive tape with adhesive before using. (Check that tape does not melt by adhesive.)
- Paste adhesive tape as indicated in the right figure not to be peeled off by the doctor even after the belt goes round.

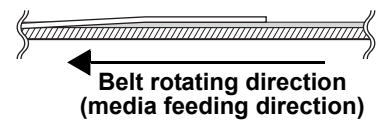

# 2

## Set the doctor on the belt referring to the Step 2 and 3 in “Peel weakened adhesive”.

The cog of the doctor shall be in the direction in the photo seen from the right side surface.

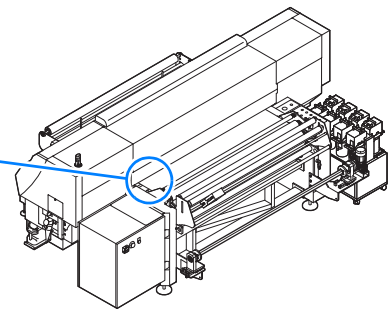

# 3

## Fix the plastic comas (x 2) attached to this machine on the doctor with adhesive tape.

- On the adhesive tape pasted on the belt, paste one plastic coma each for right and left on the side with adhesive coated of the doctor.



4

Set it to the “SERVICE” screen by pressing [SERVICE] on the operation touch panel.

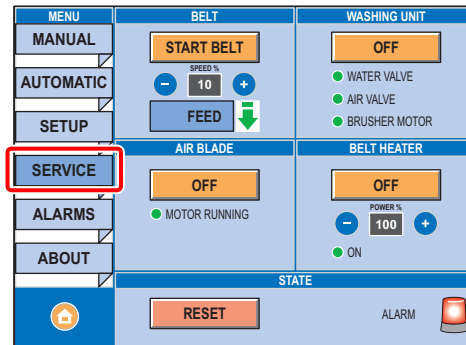

5

Adjust to 10% by pressing the [-][+] key of “BELT”.

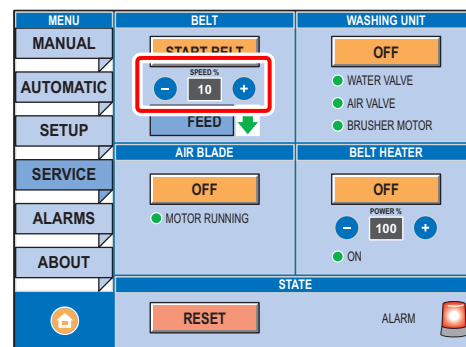

6

First check that there is not the fabric or other object on the feeding belt, and then press the [BELT OFF] to operate the belt.

**Important!**

- Confirm that “BELT HEATER” is [OFF] (in orange).

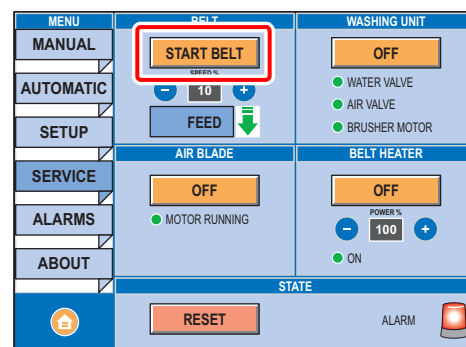

## 7 Pour adhesive on the belt evenly in the width direction.

- As adhesive is dehydrated and recoated little by little while the belt is moving round once, coat all over the belt by refilling adhesive on less part of it.

**Important!**

- If you pour large amount of adhesive at a time, it may overflow from right and left, or, it may drip off on the floor.
- If overflow adhesive drops on the belt heater just below it, there is danger of fire.
  - (1) Do not pour adhesive in a breath.
  - (1) Be sure to turn OFF the belt heater and the main heater.
- If adhesive dropped on the belt heater or the main heater, immediately turn OFF the power supply and contact a distributor in your district or our office to call for service.
- If adhesive dropped onto the floor, resin floor cover or coating may be melted.
- If adhesive dropped from the belt, wipe off completely with a waste cloth etc., and leave this machine for 12 hours and more before using next time. Discard a waste cloth with adhesive perfused after dehydrating it.

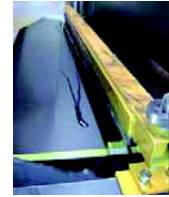

## 8 When all adhesive is poured on the belt, spray water on entire doctor width with the atomizer while adhesive is pooled in the doctor.

- By spraying water, you can decrease lines that will occur on adhesive when there becomes no adhesive on the doctor.



## 9 Remove the doctor when there is no adhesive on the doctor and wipe off adhesive sticking to the doctor with waste cloth immersed in kerosene (diesel oil).

**Important!**

- Check that there is no adhesive on the doctor before removing it. If you remove the doctor with adhesive left, adhesive on the doctor drip off on the belt and it may cause concavity and convexity.

## 10 Change the belt speed.

- Adjust to 20% by pressing the [-][+] key of "BELT".
- To dehydrate adhesive, leave as it is for two or three hours. (Keep the belt heater and the main heater "OFF" during leaving.)

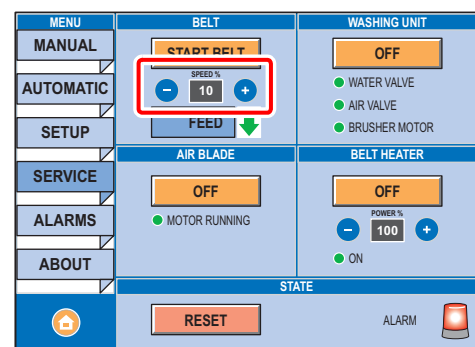

11

Stop the belt by pressing [STOP BELT].

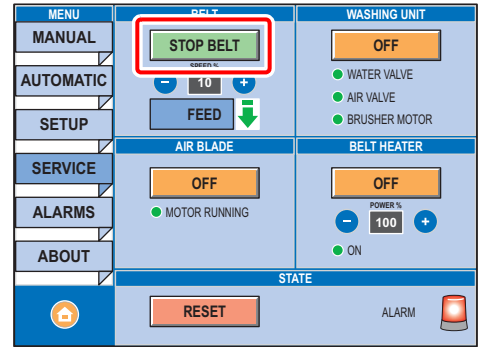

# Chapter 5

## Troubleshooting



### This chapter

describes the corrective measures to be taken for a phenomenon suspected to be trouble and the procedures to clear the error number displayed on the LCD.

Troubleshooting .....	5-2
Power does not turn on .....	5-2
The machine does not start printing .....	5-2
When an error occurs in media .....	5-3
Image quality is poor .....	5-3
Nozzle is clogged .....	5-4
Ink bottle warning appears .....	5-4
If an error related to the sub tank occurs (Error 618 to 61b) .....	5-5
If nozzle missing due to color mixture of ink or aeration .....	5-6
If negative pressure abnormality occurs .....	5-8
If a head failure error is displayed .....	5-10
Warning / Error Messages .....	5-12
Warning messages .....	5-12
Error messages .....	5-15

# Troubleshooting

Take appropriate actions as described below before taking the trouble as a failure.  
If still the problem is not solved after troubleshooting, contact your dealer or an office of MIMAKI.

## Power does not turn on

In most cases, this is due to improper connection of the power cable for the machine or computer. Check that the power cable is connected properly.

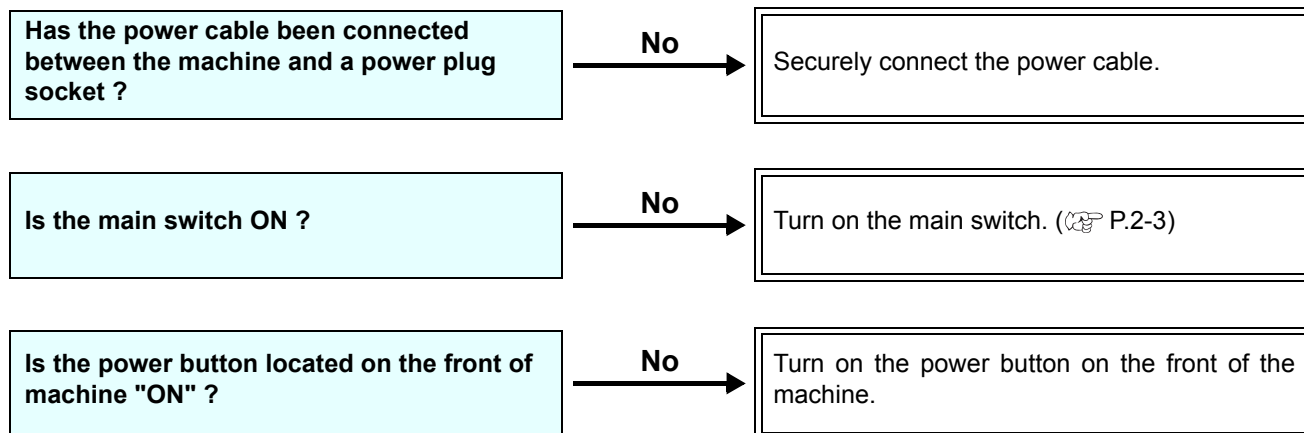

## The machine does not start printing

This occurs when the data is not being transmitted to the machine properly.  
It can also occur when the printing function does not work properly or the media is not set correctly.

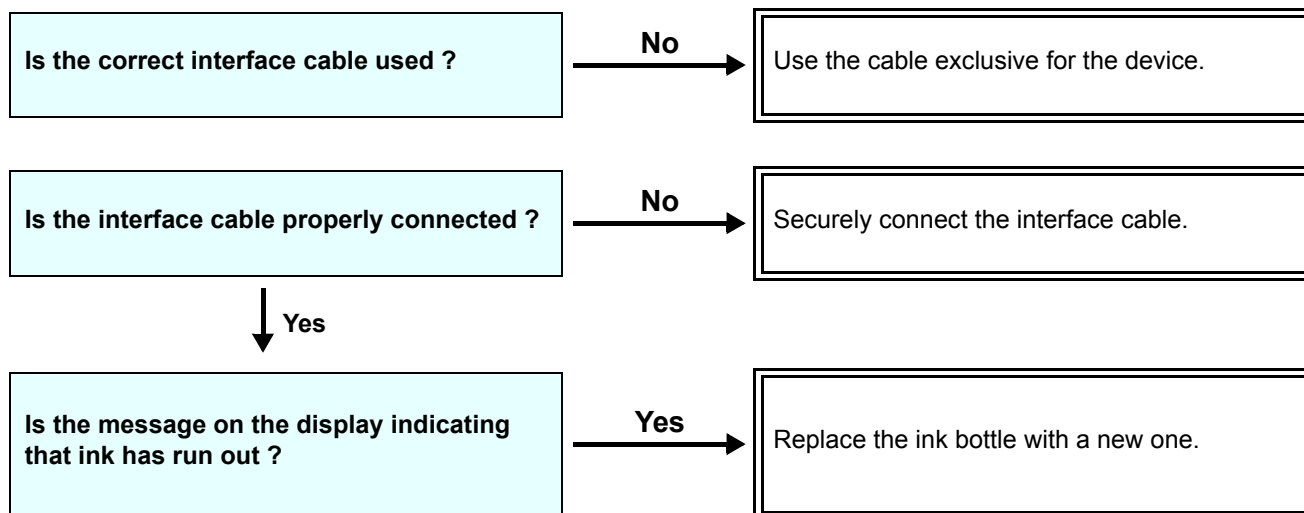



## When an error occurs in media

The countermeasures against the errors occurring in the media are described.

Phenomenon	Cause	Measures
<b>Printing is misaligned. (The fabric is fed sidling.) The fabric gets wrinkled. Ink adhered to the fabric.</b>	A preprocessed fabric which suits ink to use is not used.	Use a pre-processed fabric which suits the ink.
	A fabric which is wrinkled or folded at both edges is used.	Do not use fabrics which are wrinkled or folded at both edges.
	A fabric which is easy to be elastic by absorbing moisture is used.	Do not use fabrics which are easy to be elastic by absorbing moisture or fabrics of stretch material. (Use preprocessed nonelastic fabrics.)
	A fabric of stretch material is used.	
	The edge of the roll media is widely displaced in the width direction.	Do not use widely displaced roll media.
	The media path is not proper for the media used.	Set the proper path for the media. (☞ P.2-11)
	The rotating friction of the feeding media is not proper for the media to use.	Adjust the [CLUTCH TUNING] dial.

## Image quality is poor

This section describes the corrective actions to be taken in case the image quality is not satisfactory. Take remedy for particular problems with image quality. If the remedy does not work, contact your dealer or an office of MIMAKI.

Phenomenon	Measures
<b>White lines / blur / dark stripes (in the direction of travel of the heads)</b>	<ol style="list-style-type: none"> <li>(1) Execute the head cleaning. (☞ P.2-33)</li> <li>(2) Perform maintenance of the inside of the station. (☞ P.4-6)</li> <li>(3) Execute the [MEDIA COMP.] function. (☞ P.2-34)</li> <li>(4) If any pieces of paper or dust is attached on the path of the heads such as media press, remove it.</li> </ol>
<b>Characters are double- or triple-printed in the media feed direction</b>	<ol style="list-style-type: none"> <li>(1) Execute the [MEDIA COMP.] function. (☞ P.2-34)</li> </ol>
<b>Disagreement in print positions between outward trip and homeward trip</b>	<ol style="list-style-type: none"> <li>(1) Execute the [DROP POSITION] function. (☞ P.2-36)</li> </ol>
<b>Ink drops falling on media during printing</b>	<ol style="list-style-type: none"> <li>(1) Execute the wiper cleaning. (☞ P.4-6)</li> <li>(2) Execute the ink cap cleaning. (☞ P.4-6)</li> <li>(3) Clean around the head. (☞ P.4-15)</li> <li>(4) Execute the head cleaning [NORMAL]. (☞ P.2-33)</li> <li>(5) Set a shorter interval of INTERVAL WIPING operation. (☞ P.3-9)</li> </ol>

## Nozzle is clogged

When nozzle clogging is not dissolved even after the head cleaning referring to P.2-33, make sure the following operations.

- Wash the head nozzle by the operations of P.4-17.
- Recovery the nozzle by the operations of P.4-19.

## Ink bottle warning appears

If an ink bottle trouble is detected, the bottle LED "red" is lit, and a warning message appears. None of printing, cleaning and all the other operations that use ink is available.

If an abnormality occurs, perform the following procedures:

- Check that the IC chip in the ink cover is correctly set.
- Replace the ink bottle in question immediately.

**Important!**

- Once ink bottle trouble is displayed, do not leave the ink bottle without replacing it for a long time; otherwise, the machine will lose the nozzle clogging prevention function. If nozzles are clogged, the machine must be repaired by MIMAKI's service engineer.

## Displaying the description of ink bottle trouble

The contents of ink bottle error are confirmable by the following operations.

**1**

Press the **ENTER** key in LOCAL.

Sb300	12345678
REMAIN	34567899

**2**

Press the **ENTER** key.

NON INK IC
12345678

- When multiple bottle defects occur and if you press the **ENTER** key or **◀▶**, they are displayed by turns.

## If an error related to the sub tank occurs (Error 618 to 61b)

The Error 618 to 61b are related to the sub tank.

Execute following procedures when an error about sub tank occurs, or when the nozzle is not unclogged after cleaning.

### 1 Select [SUB TANK] of the maintenance menu.

- (1) Press the **FUNCTION** key in LOCAL.
- (2) Press **▲** **▼** to select [MAINTENANCE] and press the **ENTER** key.
- (3) Press **▲** **▼** to select [SUB TANK].

### 2 Press the **ENTER** key.

```
SELECT SUBTANK
: 12345678
```

### 3 Press **▲** **▼** **◀** **▶** and select a sub tank to be maintained.

```
SELECT SUBTANK
: 1234__78
```

- **◀** **▶** : Select a sub tank.
- **▲** **▼** : Select whether you perform maintenance or not.
- If Error 61b occurs, an appropriate head is selected. Press **ENTER** key.

### 4 Press the **ENTER** key.

```
SUB TANK
EXECUTE      [ENT]
```

### 5 Press the **ENTER** key.

- The automatic discharging operation and the filling operation are performed.

```
** FILL UP **
PLEASE WAIT
```

- Then, cleaning is performed.

```
** CLEANING **
PLEASE WAIT
```

### 6 Press **END** the key several times to end the setting.

## If nozzle missing due to color mixture of ink or aeration

If nozzle missing occurs due to color mixture of ink in the head or aeration, push ink or air in the head out from the port.



- Be aware that if you leave the device for a long time during the air purge, ink may leak from the cap section.  
If the air purge continues for 20 minutes or longer, this device forcibly shuts down the air purge in order to prevent ink leaks.



- When air goes into the print head, test print result becomes as shown below. When this happens, do the following operation.

**A batch of several nozzles are clogged**

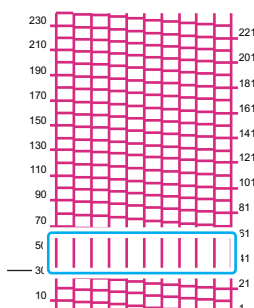

**Clogged nozzles are dispersed and does not improve even after cleaning**

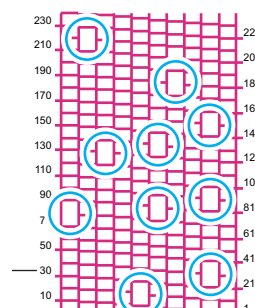

- While performing the work below, ink may leak from the cap part.  
Using a waste cloth etc., prevent ink stain on the valve part.

# 1

Select [AIR PG] of the maintenance menu.

- (1) Press the **FUNCTION** key in LOCAL.
- (2) Press **▲** **▼** to select [MAINTENANCE] and press the **ENTER** key.
- (3) Press **▲** **▼** to select [AIR PG].

# 2

Press the **ENTER** key.

PREPARE AIR PG  
COMPLETED [ENT]

# 3

Remove the right front cover and the right maintenance cover, and then remove head cover.

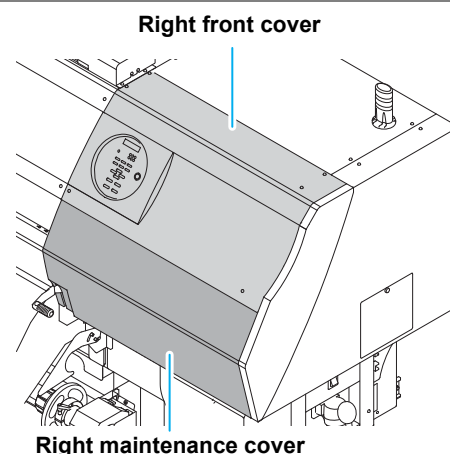

# 4

Press the **ENTER** key.

AIR PG  
START [ENT]

**5 Discharge the ink from the valve of the Y-port.**

- Insert the syringe into the valve of Y-port and then slowly withdraw about 10cc of the ink.

**Important!**

- Be careful not to spatter the ink around during the work.
- Mask the around valves properly with the waste cloth or adequate materials in order to protect the circuit board that is closely placed.



**6 Set the syringe with pressure damper to the ink port valve.**

- Insert the syringe with pressure damper into the ink port valve and suck out ink of 5cc (at a speed of 3 sec. per cc) slowly.

**Important!**

- Do not push the valve part of the syringe with pressure damper. Otherwise, ink absorption cannot be performed.
- When discarding ink in the syringe, remove the syringe part from the tube and then discard it. If you remove the syringe part, ink in the tube may run down. Before performing the work, it is recommended to cover around it with a waste close etc. to prevent it from stained.

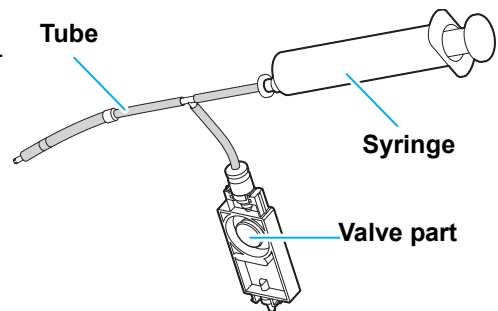
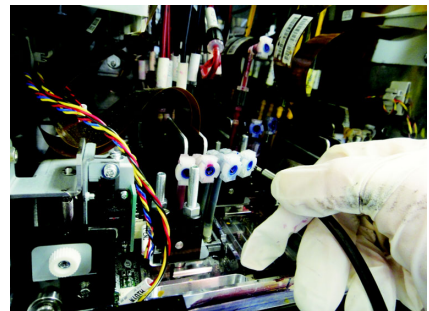

**7 Discharge ink or purge air.**

- The discharged ink or air is pooled in the bottle of the air purge jig.
- Discharge mixed ink or air completely. When it is discharged completely, clear ink (not mixed) is discharged.

**8 Perform the procedures from 5 to 7 on all ports which have to be purged the air.**

**9 Press **ENTER** key after all procedures are completed.**

AIR PG  
COMPLETED [ENT]

**10 Terminate air purge by pressing the **ENTER** key.**

- Close the port.
- When some port is skipped the air-purge, press **▶** to return to the step 4.

AIR PG  
END < > RETRY

**11 Press **◀**.**

- Cleaning is performed.

\*\* CLEANING \*\*  
PLEASE WAIT

**12 Press **END** the key several times to end the setting.**

## If negative pressure abnormality occurs

By the environment or aging, the pressure controlled in this machine may exceed the control range. If an error related to pressure abnormality occurs, perform the procedures below:

**Important!**

- If pressure abnormality occurs, immediately adjust the pressure with the following procedures and return it to the normal value.

# 1

Select [PRESSURE ADJUST] of the maintenance menu.

- (1) Press the **FUNCTION** key.
- (2) Press **▲▼** to select [MAINTENANCE] and press the **ENTER** key.
- (3) Press **▲▼** to select [PRESSURE ADJUST].

# 2

Press **▲▼** to select **POSITIVE** or **NEGATIVE**.

PRESSURE ADJUST  
: NEGATIVE

# 3

Press the **ENTER** key.

Open Throttle Valve  
COMPLETED [ENT]

# 4

Remove the cover under the left maintenance cover.

- Remove the screws (for five positions) in the part indicated with circles in the figure.

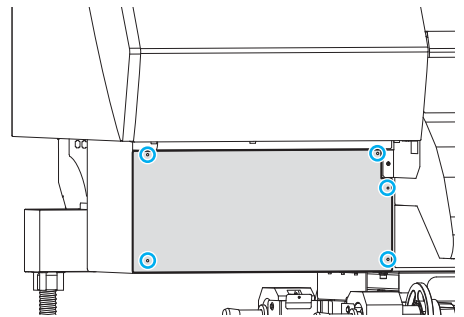

# 5

Rotate the adjustment screw of the throttle valve to release it so that air can flow.

- Rotate it until the adjustment screw of the throttle valve comes to the middle position.

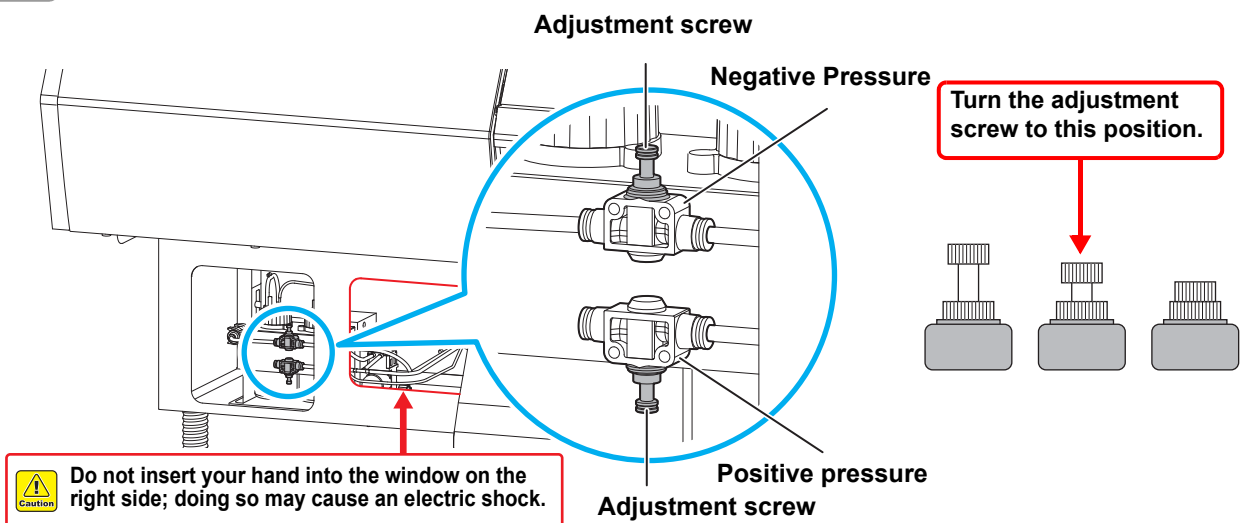

6

Press the **ENTER** key.

- Sensor adjustment starts.

\*\* ADJUSTING \*\*  
PLEASE WAIT

7

Rotate the adjustment screw of the throttle valve to adjust the pressure so that it becomes the proper value.

PRESSURE  
- 4.00 kPa (- 4.00)  
Current pressure value. Target pressure value

- Proper value of negative pressure: -4.00kPa  
Proper value of positive pressure: 15.00kPa
- As the negative pressure changes between  $\pm 0.1$ kPa, adjust so that the intermediate value may become the target pressure.



- Pressure is informed with the buzzer and the ink bottle lamp as well as the screen display.
- For the negative pressure, the buzzer stops within the range of  $\pm 0.1$ kPa. For the positive pressure, the buzzer stops within the range of  $\pm 1.0$ kPa.

- Status of lamp and buzzer for each pressure value

	Pressure		Ink bottle lamp	Buzzer
	Positive pressure	Negative pressure		
High	~ 8.49	~ -3.35	○○○○●	Sounds
	8.50 ~ 9.49	-3.36 ~ -3.45	○○○○●	
	9.50 ~ 10.49	-3.46 ~ -3.55	○○○○●	
	10.50 ~ 11.49	-3.56 ~ -3.65	○○○○●	
	11.50 ~ 12.49	-3.66 ~ -3.75	○○○○●	
	12.50 ~ 13.49	-3.76 ~ -3.85	○○○○●	
	13.50 ~ 13.49	-3.86 ~ -3.95	○○○○●	Stops
Proper value	14.50 ~ 15.49	-3.96 ~ -4.05	Y Y K K ● ● ● ● B B M M	Stops
Low	15.50 ~ 16.49	-4.06 ~ -4.15	●●●●●	Stops
	16.50 ~ 17.49	-4.16 ~ -4.25	●●●●●	Sounds
	17.50 ~ 18.49	-4.26 ~ -4.35	●●●●●	
	18.50 ~ 19.49	-4.36 ~ -4.45	●●●●●	
	19.50 ~ 20.49	-4.46 ~ -4.55	●●●●●	
	20.50 ~ 21.49	-4.56 ~ -4.65	●●●●●	
	21.50 ~ 22.49	-4.66 ~ -4.75	●●●●●	
	22.50 ~ 23.49	-4.76 ~ -4.85	●●●●●	
23.50 ~	-4.86 ~	●●●●●		

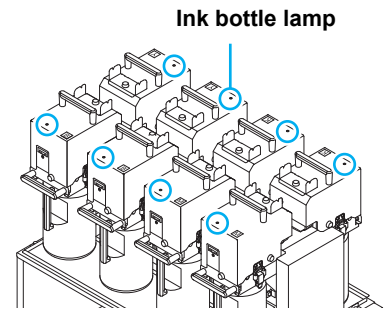

8

Press the **ENTER** key.

- The error is released and the negative pressure control starts.

PLEASE WAIT

**Important!**

- When an error occurs even after you adjusted the pressure, contact your local distributor to call for service.

## If a head failure error is displayed

If the above errors occur when the power is turned on, you can use the following procedure to continue operation.

### Head failure error to be subjected

If the head failure error that has not been described here has been displayed turn off the power to the machine and turn it on after a while. If the same error message appears again, contact your local distributor to call for service.

Error No.	Cause	Error No.	Cause
<b>ERROR 108</b> (HD CONNECT)	Head connection can not be confirmed.	<b>ERROR 1ab</b> (HD THERMIS)	Temperature of the head could not be read
<b>ERROR 12e</b> (HEAD Failed/ HDD)	Abnormality of the Driver of the Print head.	<b>ERROR 1ad</b> (HD TYPE)	Head type is different
<b>ERROR 1ac</b> (HD MEM EMP)	There is no data in the head memory		



**During the head failure error occurs, printing is possible using a different head that is operating normally.**

- **For a partial head failure**

- ⇒ printing is possible using a different head that is operating normally.

- ⇒ Feed correction (☞ P.2-34), correct the ink drop position (☞ P.2-36), test print(☞ P.2-31) are possible using heads other than the heads where the failure occurred.

- **For a total head failure**

- ⇒ Only maintenance such as cleaning is possible.

- ⇒ Flushing is not possible for the head where the failure occurred.

- ⇒ Refresh(☞ P.4-23) is not possible even if Refresh is selected during auto maintenance. (Cleaning is performed.)



## What to do if an error occurs

**1** Error number is displayed on the display.

```
ERROR 108
HD CONNECT [ 1 2 3 4 5 6 ]
```



```
ERROR 108
PRESS [ENT] KEY
```

**2** Press the **ENTER** key.

```
ACT LIMIT
HEAD SELCT [ENT]
```

**Important!**

- If all heads are not usable, the right screen appears. In this case, only maintenance is possible.

```
ACT LIMIT
Can'tPRINT/BTL [ENT]
```

**3** Press the **ENTER** key.

- Head line select screen appears.

```
HEAD SELCT
:HEADLine1&2
```

**4** Press **▲** **▼**, to select head line to use.

- You cannot select a head where an error has occurred. (If there is a failure in head line 2, you cannot select head lines 1 & 3.)

```
HEAD SELCT
:HEADLine1&2
```

**5** When the operation is complete, the **Select Media** screen appears and can be used.

```
MEDIA SELECT
ROLL < > LEAF
```

**Important!**

- During printing, an "X" is displayed for the head line that includes the head where the failure occurred.

# Warning / Error Messages

If some trouble occurs, the buzzer sounds and the display shows a corresponding error message. Take an appropriate remedy for the displayed error.

## Warning messages

### Errors when performing operations

Message	Cause	Solution
CAN'T OPERATE COVER OPEN	The front cover or the maintenance cover is opened.	<ul style="list-style-type: none"> <li>Check the front cover and maintenance covers.</li> <li>If the same error message appears again even after closing all the covers, contact your local distributor to call for service.</li> </ul>
CAN'T OPERATE MEDIA UNDETECTED	The media has not been detected.	<ul style="list-style-type: none"> <li>Perform media detection.</li> </ul>
CAN'T OPERATE MOTOR POWER OFF	The motor is OFF after the cover was opened etc.	<ul style="list-style-type: none"> <li>Close the front cover and maintenance covers (right and left).</li> </ul>
CAN'T OPERATE INK ERROR	An ink error occurred.	<ul style="list-style-type: none"> <li>Check the ink bottle for the supply path corresponding to the indicated color.</li> </ul>
CAN'T OPERATE DATA REMAIN	Data was received.	<ul style="list-style-type: none"> <li>Perform data clear. (☞ P.2-39)</li> </ul>

### Message displayed in LOCAL

Message	Cause	Solution
<LOCAL> Can't PRINT / CART. [ENT]	Ink errors (unusable ink) occur in multiple ink bottles. Ink supply (print, cleaning, etc.) cannot be performed.	<ul style="list-style-type: none"> <li>Press the <b>ENTER</b> key to check the ink bottle generating the warning. Replace them with usable ink bottles.</li> </ul>
<LOCAL> Waste ink full	The waste ink tank is full.	<ul style="list-style-type: none"> <li>Check the waste ink tank.</li> </ul>
<LOCAL> Waste ink near full	The waste ink tank is nearly full.	
<LOCAL> Waste ink tank none	The waste ink tank is not set.	<ul style="list-style-type: none"> <li>Set the waste ink tank.</li> </ul>
<LOCAL> Replace a WIPER[MNT]	Time to replace the wiper in the capping station with a new one has come. (The wiping count has reached the specified value.)	<ul style="list-style-type: none"> <li>Press the <b>MAINT.</b> key and replace the wiper with a new one. (☞ P.4-26)</li> </ul>
<LOCAL> ** NO MEDIA **	The media is not set. The sensor has been broken.	<ul style="list-style-type: none"> <li>Set the media. (☞ P.2-11) If the same error message appears again, contact your local distributor to call for service.</li> </ul>
<LOCAL> DATA REMAIN	The data has been received.	<ul style="list-style-type: none"> <li>Press the <b>REMOTE</b> key to perform printing. Or, perform data clear.</li> </ul>
<LOCAL> NEGATIVE PRESSURE	The value of the negative pressure sensor is abnormal.	<ul style="list-style-type: none"> <li>Perform "PRESSURE ADJUST" (☞ P.5-8) of the maintenance. If you cannot adjust it to the normal value, or, even if you perform, it may be displayed, contact your local distributor to call for service.</li> </ul>

Message	Cause	Solution
<LOCAL> POSITIVE PRESSURE	The value of the positive pressure sensor is abnormal.	<ul style="list-style-type: none"> <li>Perform "PRESSURE ADJUST" (☞ P.5-8) of the maintenance. If you cannot adjust it to the normal value, or, even if you perform, it may be displayed, contact your local distributor to call for service.</li> </ul>
<LOCAL> NEGATIVE P. ADJUST	Pressure needs to be adjusted.	
<LOCAL> INK NEAR END [ENT]	The ink of the ink bottle has been nearly used up.	<ul style="list-style-type: none"> <li>Press the <b>ENTER</b> key to check the relevant ink bottle. Be careful because it may be INK NEAR END soon.</li> </ul>
<LOCAL> EXPIRATION [ENT]	The specified expiration date of an ink bottle has passed.	The expiration date has passed. However, you can use it until the end of the following month.
<LOCAL> EXPIRATION (1M) [ENT]	The expiration date of an ink bottle has passed (one month has passed after the specified expiration date).	<ul style="list-style-type: none"> <li>One month has passed after the expiration date. However, you can use it until the end of this month. (The ink bottle lamp blinks in red.)</li> </ul>
<LOCAL> EXPIRATION (2M) [ENT]	The expiration date of an ink bottle has passed (two months have passed after the specified expiration date).	<ul style="list-style-type: none"> <li>Two months have passed after the expiration date. Replace the ink bottle generating the warning with a new one.</li> </ul>
<LOCAL> SUPPLY INK : 12345678	Ink could not be supplied to the sub tank.	<ul style="list-style-type: none"> <li>Perform "SUB TANK" (☞ P.5-5) of the maintenance. Also check the remaining amount of ink in the ink bottle. Even if you performed this, when the message is displayed, contact your local distributor to call for service.</li> </ul>
<LOCAL> Sub tank Sens : 12345678	The liquid level sensor abnormality of the sub tank has been detected.	<ul style="list-style-type: none"> <li>Turn off the power to the machine and turn it on after a while.</li> <li>If the same error message appears again, contact your local distributor to call for service.</li> </ul>
<LOCAL> Ink Overflow : 12345678	Overflow from the sub tank has been detected.	<ul style="list-style-type: none"> <li>Perform "SUB TANK" (☞ P.5-6) of the maintenance. Even if you performed this, when the message is displayed, contact your local distributor to call for service.</li> </ul>
<LOCAL> TANK level H : 12345678	Though a certain amount was consumed, there is no change in the sub tank sensor High.	
<LOCAL> TANK level L : 12345678	Though a certain amount was consumed, there is no change in the sub tank sensor Low.	
<LOCAL> Replace DeAirModule	The deaeration module in the ink path shall be replaced soon. (One year has passed since you started using it.)	<ul style="list-style-type: none"> <li>The deaeration module shall be replaced. Contact a distributor in your district, our office, or our call center.</li> </ul>
<LOCAL> MachineTEMP/Hi ***°C	The machine temperature is high.	<ul style="list-style-type: none"> <li>Adjust the ambient temperature of the installation place. (20 °C to 30 °C (68°F?86°F))</li> </ul>
<LOCAL> MachineTEMP/Lo ***°C	The machine temperature is low.	
<LOCAL> Ymotor Cleaning[MNT]	Time to clean the Y motor has come.	<ul style="list-style-type: none"> <li>Turn off the power and vacuum debris of the Y motor from the vacuuming window. (☞ P.4-25)</li> <li>After the replacement, press the <b>MAINT.</b> key on the local screen to clear the warning.</li> </ul>
<LOCAL> Replace Ymotor Brush	Time to replace the brush of Y motor has come.	<ul style="list-style-type: none"> <li>The brush of Y motor shall be replaced. Contact a distributor in your district, our office, or our call center.</li> </ul>

Message	Cause	Solution
Mist Filter Please Replace [ENT]	Time to replace the mist filter has come.	<ul style="list-style-type: none"> <li>For replacing the filter, refer to the separate "Requests for Daily Care and Maintenance".</li> </ul>

## Ink Error

Ink error is displayed also in the local guidance. (☞ P.3-43)

Message	Cause	Solution
NON INK IC :---- 5678	The IC chip of the ink bottle cannot be read normally.	<ul style="list-style-type: none"> <li>Remove the IC chip generating the warning once and install it again.</li> <li>If the same warning message still appears, contact your local distributor to call for service.</li> </ul>
WRONG INK IC :---- 5678		
KIND OF INK :---- 5678	The ink of the ink bottle is different in type from the ink currently supplied.	<ul style="list-style-type: none"> <li>Check the ink type of the ink bottle generating the warning.</li> <li>Check the IC chip.</li> </ul>
COLOR OF INK :---- 5678	The ink of the ink bottle is different in color from the ink currently supplied.	<ul style="list-style-type: none"> <li>Check the ink color of the ink bottle generating the warning.</li> <li>Check the IC chip.</li> </ul>
WRONG INK BOTTLE :---- 5678	An error occurred in the IC chip information of the ink bottle.	<ul style="list-style-type: none"> <li>Check the ink bottle generating the warning.</li> </ul>
NO INK BOTTLE :---- 5678	The ink bottle is not set on the external ink supply unit.	<ul style="list-style-type: none"> <li>Set the ink bottle on the bottle holder with the warning.</li> </ul>
INK END :---- 5678	The ink of the ink bottle has been completely used up.	<ul style="list-style-type: none"> <li>Replace the ink bottle generating the warning with a new one.</li> </ul>
INK NEAR END :---- 5678	The ink of the ink bottle has been nearly used up.	<ul style="list-style-type: none"> <li>Replace the ink bottle generating the warning with a new one.</li> </ul>
CHCK INK BOTTLE :---- 5678	Even when there are enough ink, ink end has been detected.	<ul style="list-style-type: none"> <li>Check the ink bottle setting status.</li> </ul>
EXPIRATION :---- 5678	The specified expiration date of an ink bottle has passed.	The expiration date has passed. However, you can use it until the end of the following month.
EXPIRATION ( 1MONTH ) :---- 5678	The expiration date of an ink bottle has passed (one month has passed after the specified expiration date).	<ul style="list-style-type: none"> <li>One month has passed after the expiration date. However, you can use it until the end of this month. (The ink bottle lamp blinks in red.)</li> </ul>
EXPIRATION ( 2MONTH ) :---- 5678	The expiration date of an ink bottle has passed (two months have passed after the specified expiration date).	<ul style="list-style-type: none"> <li>Two months have passed after the expiration date. Replace the ink bottle generating the warning with a new one.</li> </ul>

## Error messages

When an error message is displayed, eliminate the error according to the chart below.

If the same error message appears again, contact your dealer or an office of MIMAKI to call for service.

Message	Cause	Solution
ERROR 108 HD CONNECT [ 12345678 ]	Head connection can not be confirmed.	<ul style="list-style-type: none"> <li>• Turn off the power to the machine and turn it on after a while. If the same error message appears again, contact your local distributor to call for service.</li> </ul>
ERROR 108 HD THERMIS [ 12345678 ]	Head temperature can not be read.	
ERROR 12a HDC SPEED	Abnormality of the ink discharge waveforms.	
ERROR 12e HeadFaild /HDC [xxxx]	Abnormality of the Driver of the Print head.	
ERROR 122 CHECK: SDRAM	There is no PRAM.	
ERROR 128 HDC FIFO OVER	Data transmission speed is too fast. Control circuit board is defective.	
ERROR 128 HDC FIFO UNDER	Data transmission speed is too slow. Control circuit board is defective.	
ERROR 129 BATTERY EXCHANGE	The battery life end of the internal clock is detected.	<ul style="list-style-type: none"> <li>• Contact your local distributor to call for service.</li> </ul>
ERROR 130 HD DATA SEQ	Head data transferring sequence error occurred.	<ul style="list-style-type: none"> <li>• Turn off the power to the machine and turn it on after a while. If the same error message appears again, contact your local distributor to call for service.</li> </ul>
ERROR 146 E-LOG SEQ	Sequential number abnormality of the event log occurred.	
ERROR 151 Main PCB V12R	An error occurred in the main PCB 1.2V power supply.	
ERROR 152 Main PCB V2R5	An error occurred in the main PCB 2.5V power supply.	
ERROR 153 Main PCB V3R3	An error occurred in the main PCB 3.3V power supply.	
ERROR 154 Main PCB V05	An error occurred in the main PCB 5V power supply.	
ERROR 155 Main PCB V36-1	An error occurred in the main PCB 36-1 power supply.	
ERROR 156 Main PCB V5B	An error occurred in the main PCB 5VB power supply.	
ERROR 157 Main PCB VTT	An error occurred in the main PCB VTT power supply.	
ERROR 158 Main PCB V36-2	An error occurred in the main PCB 36-2V power supply.	

Message	Cause	Solution
ERROR 16e Main PCB V3R3B	An error occurred in the main PCB 3.3VB power supply.	
ERROR 18a Main PCB V_CORE	An error occurred in the main PCB VCORE power supply.	
ERROR 18b Main PCB V1R5B	An error occurred in the main PCB 1.5V power supply.	
ERROR 18c Main PCB V12	An error occurred in the main PCB 12V power supply.	
ERROR15f HEAD DRIVE HOT	COM driver becomes the high temperature.	
ERROR 171 NEW HEAD CONNECT	New Print Head was recognized.	
ERROR 172 Main PCB Q6 Check K	The main PCB Q6 is disabled (short mode).	
ERROR 186 HDC OVERFLOW	An error is detected on the waveform printed on.	<ul style="list-style-type: none"> <li>• Turn off the power to the machine and turn it on after a while.</li> <li>If the same error message appears again, contact your local distributor to call for service.</li> </ul>
ERROR 186 HDC UNDERFLOW		
ERROR 187 HDC SLEW RATE		
ERROR 188 HDC MEMORY		
ERROR 18e FLS NOT COMP [12__]	Abnormality of the flushing control.	
ERROR 18f OFFSET START [12__]	Abnormality of the head voltage control.	
ERROR 18f OFFSET END [12__]		
ERROR 19d HDC V36 [xxxx]	Abnormality of the HDC substrate voltage.	
ERROR 201 COMMAND	The machine received some data other than command data.	<ul style="list-style-type: none"> <li>• Securely connect the interface cable in position.</li> <li>• Use an interface cable conforming to the specifications.</li> </ul>
ERROR 202 PARAMETER	Any parameter outside the range of acceptable numeric values was received.	
ERROR 203 Ment Command	A maintenance command error occurred.	
ERROR 304 USB INIT ERR	USB device initialization failure.	<ul style="list-style-type: none"> <li>• Turn off the main power to the machine and turn it on after a while.</li> <li>If the same error message appears again, contact your local distributor to call for service.</li> </ul>

Message	Cause	Solution
ERROR 305 USB TIME OUT	Occurrence of a time out error on a USB device.	
ERROR 401 MOTOR X	An excessive load was applied to the X motor.	
ERROR 402 MOTOR Y	An excessive load was applied to the Y motor.	<ul style="list-style-type: none"> <li>• Turn off the main power to the machine and turn it on after a while.</li> <li>If the same error message appears again, contact your local distributor to call for service.</li> </ul>
ERROR 403 X CURRENT	An error due to an excessive current of the X motor was detected.	
ERROR 404 Y CURRENT	An error due to an excessive current of the Y motor was detected.	
ERROR 44d STATION POS ERROR	An error occurred in the station position.	
ERROR 505 MEDIA JAM	The media jam occurs.	<ul style="list-style-type: none"> <li>• Remove the media and reset it.</li> </ul>
ERROR 50c MEDIA WIDTH SENSOR	The media width has not been detected correctly.	<ul style="list-style-type: none"> <li>• Check the media set position. (☞ P.2-21)</li> <li>• Clean the media sensor. (☞ P.4-3)</li> </ul>
ERROR 50c MEDIA WIDTH SENSOR	The media width has not been detected correctly.	<ul style="list-style-type: none"> <li>• Check the media set position. (☞ P.2-21)</li> </ul>
ERROR 509 HDC POSCNT	A HDC position counter error occurred.	<ul style="list-style-type: none"> <li>• Turn off the main power to the machine and turn it on after a while.</li> <li>If the same error message appears again, contact your local distributor to call for service.</li> </ul>
ERROR 50a Y ORIGIN	Y-origin could not be detected.	
ERROR 50f L-SCALE BLACK	Abnormal linear scale.	
ERROR 519 NEGATIVE P. SENSOR	The value of the negative pressure sensor is abnormal.	<ul style="list-style-type: none"> <li>• Perform "PRESSURE ADJUST" (☞ P.5-8) of the maintenance. If you cannot adjust it to the normal value, or, even if you perform, it may be displayed, contact your local distributor to call for service.</li> </ul>
ERROR 51a POSITIVE P. SENSOR	The value of the positive pressure sensor is abnormal.	
ERROR 53c Print Pos HDC	An error occurred in the linear scale coordinates.	<ul style="list-style-type: none"> <li>• Turn off the main power to the machine and turn it on after a while.</li> <li>If the same error message appears again, contact your local distributor to call for service.</li> </ul>
ERROR 617 SUBTANK SNN : 12345678	The liquid level sensor abnormality of the sub tank has been detected.	
ERROR 618 TANK levelH : 12345678	Though a certain amount was consumed, there is no change in the sub tank sensor High.	<ul style="list-style-type: none"> <li>• Perform "SUB TANK" (☞ P.5-5) of the maintenance. Even if you performed this, when the message is displayed, contact your local distributor to call for service.</li> </ul>
ERROR 619 TANK levelL : 12345678	Though a certain amount was consumed, there is no change in the sub tank sensor Low.	
ERROR 61a OVER FLOW : 12345678	Overflow from the sub tank has been detected.	

Message	Cause	Solution
ERROR 61b SUPPLY INK : 12345678	Ink could not be supplied to the sub tank.	<ul style="list-style-type: none"> <li>Perform "SUB TANK" (☞ P.5-5) of the maintenance. Also check the remaining amount of ink in the ink bottle. Even if you performed this, when the message is displayed, contact your local distributor to call for service.</li> </ul>
ERROR 61c NEGATIVE P. CONTROL	Starting of the negative pressure control has an abnormality.	<ul style="list-style-type: none"> <li>Perform "PRESSURE ADJUST" (☞ P.5-8) of the maintenance. If you cannot adjust it to the normal value, or, even if you perform, it may be displayed, contact your local distributor to call for service.</li> </ul>
ERROR 61d NEGATIVE P. NotEnough	The negative pressure cannot be kept properly	
ERROR 61e NEGATIVE P. OVER		
ERROR 61f POSITIVE P. CONTROL	Starting of the positive pressure control has an abnormality.	
ERROR 620 POSITIVE P. NotEnough	The positive pressure cannot be kept properly.	
ERROR 621 POSITIVE P. OVER		
ERROR 627 INSERT CARTRIDGE	There is a slot in which the ink bottle has not been inserted more than a certain time.	Set an ink bottle.
ERROR 637 INK LEAK 1--	The ink leakage is detected in the ink supply path.	<ul style="list-style-type: none"> <li>Turn off the main power to the machine and turn it on after a while.</li> <li>If the same error message appears again, contact your local distributor to call for service.</li> </ul>
ERROR 649 NEGATIVE P. ADJUST	Pressure needs to be adjusted.	<ul style="list-style-type: none"> <li>Perform "PRESSURE ADJUST" (☞ P.5-8) of the maintenance. If you cannot adjust it to the normal value, or, even if you perform, it may be displayed, contact your local distributor to call for service.</li> </ul>
ERROR 702 THERMISTOR	The thermistor of a heater is defective.	Turn off the main power to the machine and turn it on after a while. If the same error message appears again, contact your local distributor to call for service.
ERROR 707 !H1 HEATER BREAK	A head heater is disconnected.	
ERROR 901 シッコウ テキマセン	You have executed the operation that cannot be performed.	
ERROR 902 DATA REMAIN	There remains received data that has not yet been printed.	Execute the data clear function. (☞ P.2-39)
ERROR 90d NO HEAD SELECT	The number of mounted heads is 0 (zero).	<ul style="list-style-type: none"> <li>Turn off the main power to the machine and turn it on after a while.</li> <li>If the same error message appears again, contact your local distributor to call for service.</li> </ul>
ERROR 910 ENVIRONMENT TEMP (LO)	The ambient temperature is out of the usable temperature range (too low).	<ul style="list-style-type: none"> <li>Adjust the ambient temperature of the installation place.</li> </ul>
ERROR 911 ENVIRONMENT TEMP (HI)	The ambient temperature is out of the usable temperature range (too high).	



## SYSTEM HALT

Message	Solution
SYSTEM HALT 000 : MESSAGE	Turn off the main power to the machine and turn it on after a while. Check the number and contact your local distributor to call for service. ("000" is the error No.)

## X-unit Error

Message	Cause	Solution
EMERGENCY BUTTON PRESSED	EMERGENCY button was pressed, or electrical BOX cover opened.	• Please cancel EMERGENCY button, or close electrical BOX cover.
PLC BATTERY LOW	It detected that PLC run out of battery.	• Please call our customer service or dealers.
EMERGENCY ERROR	There was abnormality in printer part.	• Please check the error message of the printer part.
MEDIA END ERROR	media end function was active, but it could not detect media.	• Please check whether media end sensor is set in correct position.
MEDIA NEAR TO WASHING UNIT	It detected that media got closer to washing unit.	• Please perform cleaning of peeling sensor.
PRESSURE ROLLER NOT IN POSITION	Abnormality in pressure roller position was detected.	• Please check whether pressure roller stopper pin is not inserted. Also, please check whether foreign substance is not pinched under the pressure roller.
LOW AIR PRESSURE	Air pressure is less than 6 bar, and it is not enough.	• Please check whether air is supplied.
MAIN HEATER ALARM	Media heater is not connected.	<ul style="list-style-type: none"> <li>• Please turn OFF all the power once, and after a while, please turn ON. If you want to show the message again, please call our service engineer or dealers.</li> </ul>
COMMUNICATION ERROR	There was abnormality in communication between media feeding part and printer part.	
TAKE UP MOTOR INVERTER FAULT	There was abnormality in take-up motor inverter.	
PRESSURE ROLLER MOTOR INVERTER FAULT	There was abnormality in pressure roller motor inverter.	
BRUSHER MOTOR INVERTER FAULT	There was abnormality in washing brush motor inverter.	
BELT MOTOR INVERTER FAULT	There was abnormality in belt motor inverter.	
AIR BLADE UNIT MOTOR FAULT	There was abnormality in air blade blower.	
BELT HEATER FAULT	There was abnormality in belt heater.	
CENTERING UNIT MOTOR FAULT	There was abnormality in centering motor.	
TAKE UP MOTOR FAN FAULT	There was abnormality in take-up motor.	

Message	Cause	Solution
WASHING UNIT BRUSHER MOTOR FAULT.	There was abnormality in washing brush motor.	<ul style="list-style-type: none"><li>• Please check whether it does not get media rolled together in belt washing unit. Please turn OFF all the power once, and after a while, please turn ON. If you want to show the message again, please call our service engineer or dealers.</li></ul>

# Chapter 6

## Appendix



### **This chapter**

contains the lists of the specifications and functions of this machine.

Specifications .....	6-2
Machine specifications .....	6-2
Ink specifications .....	6-3
Setting orders depending on ink type .....	6-4
Setting orders of ink bottles .....	6-4
Sheet for inquiry .....	6-5
Warning labels .....	6-6
Function Flowchart .....	6-8

# Specifications

## Machine specifications

Item		Specifications
Print head	Method	Drop-on-demand piezoelectric print heads
	Specification	6 heads: 3-layered staggered arrangement in 2-line
Drawing mode (scan x feed)	4 colors	300x300 : Bi/Uni 1/2/4 pass (only normal mode) 300x300HQ : Bi/Uni 2/4/8 pass (only normal mode) 300x450HQ : Bi/Uni 3/6/12 pass (only normal mode) 600x600 : Bi/Uni 4/8/16 pass 600x900 : Bi/Uni 6/12/24 pass 600x1200 : Bi/Uni 8/16/32 pass
	6 colors or more	300x300 : Bi/Uni 2/4/8 pass (only normal mode) 300x300HQ : Bi/Uni 4/8/16 pass (only normal mode) 600x450 : Bi/Uni 6/12/24 pass 600x600 : Bi/Uni 8/16/32 pass 600x900 : Bi/Uni 12/24/48 pass 600x1200 : Bi/Uni 16/32/64 pass
Usable inks	Acidic dye ink	Ac300 (K, C, M, Y, Lk, Bl, R, Or)
	Reaction dye ink	Rc300 (K, C, M, Y, Lk, Bl, R, Or)
	Sublimation dye ink	Sb300, Sb320 (KD, Bl, M, Y, Lb, Lm)
Ink supply		Supplying 2L x 8 bottles (For 4-color, UISS switching is available/ for 6-color, UISS switching is available only for Y, K./ You can transfer the remaining ink in the used ink bottle to the new one.)
Capacity of ink bottle	4 colors	2L-bottle x 2 for each color
	6 colors	M, B, Lm, Lb: 2L-bottle x 1 for each color Y, K: 2L-bottle x 2 for each color
	8 colors	2L-bottle x 1 for each color
Media type		Cotton, silk, knit, polyester, stretch, etc.
Max. printing width		1850mm
Roll Media size	Maximum	1860mm
	Minimum	210mm or less
	Thickness	5.0 mm or less
	Roll outside diameter	φ 420mm or less
	Roll weight <sup>*1</sup>	60kg or less
	Roll inside diameter	2 ~ 3 inch
	Printing surface	Regardless of faces out and in
	Roll end treatment	The roll end is gently fixed to the core with weak-adhesive tape or weak glue for easy removal.
Margin		Front edge up to the winding unit set : 1.7m Rear edge of the feeding unit paper pipe removing : 3.2m
Distance accuracy	Absolute accuracy	Larger one of ±0.5 mm or ±0.3 % of the designated distance, However, depending upon the feeding and winding unit.
	Reproducibility	
Perpendicularity		± 0.5 mm / 1000 mm
Media skew		5 mm or less / 10 m variable
Head height adjustment		1.5mm to 7mm Single-step user setting
Waste ink tank		Bottle type (3,200 cc) / Detected by sensor
Interface		USB 2.0
Command		MRL- III
Noise	during standby	Less than 58 dB (FAST-A, Front & Rear & Left & Right 1 m)
	during continuous printing	Less than 65 dB
	during discontinuous printing	Less than 70 dB
Safety Standard		VCCI-Class A, FCC-Class A, UL 60950, CE Marking (EMC, Low Voltage Directive, Machinery Directive), RoHS
Power		Three-phase AC380 - 420V ± 10% , 50/60Hz ± 1Hz , 20A or less <sup>*2</sup> , Y-connection
Power consumption <sup>*2</sup>		10 kVA or less

Item		Specifications
Recommended Environment	Available temp.	20 °C to 30 °C (68°F to 86°F)
	Humidity	35 to 65% Rh (No condensation)
	Guaranteed temp.	20 °C to 25 °C (68°F to 77°F)
	Temperature change	± 10 °C / h or less
	Dust	0.15mg/m <sup>3</sup> (Equivalent to normal office level)
	Highest operation height	2000 m
Weight	Printer main unit	1840 kg or less
	External ink supply unit	30 kg
Outside dimensions	Printer main unit	3895 mm(W) x 2750 mm(D) x 1640mm(H)
	External ink supply unit	775 mm(W) x 490 mm(D) x 785mm(H)

\*1. Without deflection of the roll when it is retained at both ends.

\*2. Excepting the media heater (option)

## Ink specifications

Item		Specifications
Supply		2L Ink bottle
Color	Acidic dye ink	Black / Cyan / Magenta / Yellow / Light black / Blue / Red / Orange
	Reaction dye ink	Black / Cyan / Magenta / Yellow / Light black / Blue / Red / Orange
	Sublimation dye ink	Black D / Blue / Magenta / Yellow / Light blue / Light magenta
Ink capacity		2 liter
Shelf life		The period is printed on the ink bottle. Within three months after opening the package even in the available period.
Storage temperature	Storage	1 to 40 °C (Storage at temperature of 40 °C is permitted within a month.)
	Transportation	1 to 60 °C (Storage at temperature of 60 °C is only permitted within 120 hours, and at temperature of 40 °C is permitted within a month.)

**Important!**

- **Do not disassemble the ink bottle.**
- **Ink could freeze if kept in a cold place for an extended period.**
  - If the ink freezes, thaw it at room temperature (25°C) spending more than three hours before use. However, when you use the frozen ink, the printing quality becomes degraded due to altered ink. Store ink in the environment where ink may not freeze.

# Setting orders depending on ink type

The setting value and the setting orders of the ink bottles differ depending on the ink type you use.

## Setting orders of ink bottles

The orders of ink bottles set in the ink station differ depending on the ink set you use.



- Set the ink bottle aligning with the label pasted on the top surface of the ink cover.

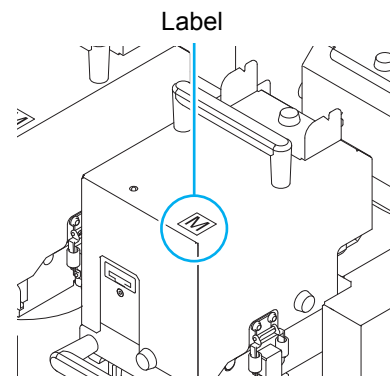

[2]	[2]	[1]	[1]	<b>4 colors model</b>	[4]	[4]	[3]	[3]
[4]	[3]	[2]	[1]	<b>6 colors model</b>	[6]	[5]	[6]	[5]
[4]	[3]	[2]	[1]	<b>8 colors model</b>	[8]	[7]	[6]	[5]

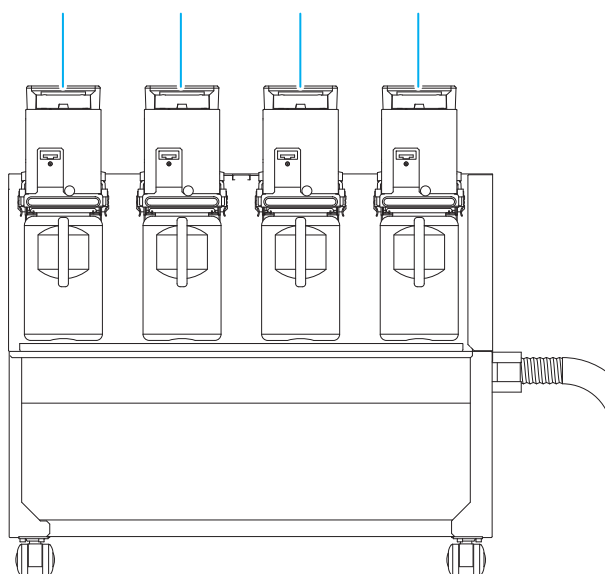

The front side

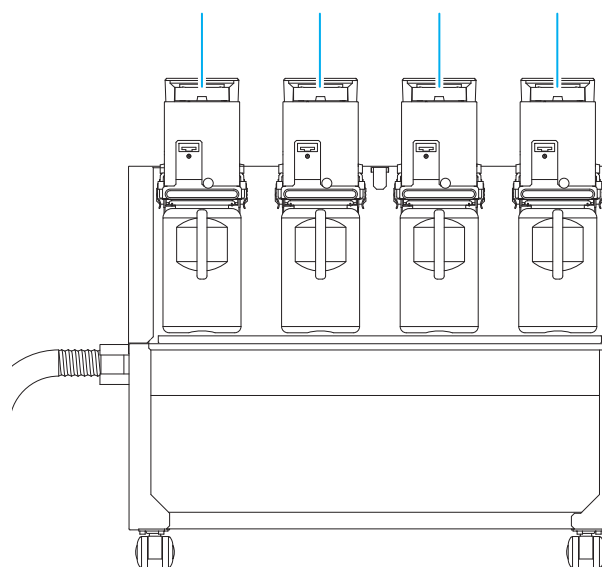

The front side



- When setting the inks of 4colors/6 colors, be sure to set the ink bottles of the same colors according to the order above.

# Sheet for inquiry

Use this sheet for troubles and abnormal functions of the machine.  
Fill in the following necessary items, and then fax the sheet to our sales office.

<b>Company name</b>	
<b>Person in charge</b>	
<b>Telephone number</b>	
<b>machine model</b>	
<b>Operating OS</b>	
<b>Machine information *1</b>	
<b>Error message</b>	
<b>Contents of inquiry</b>	





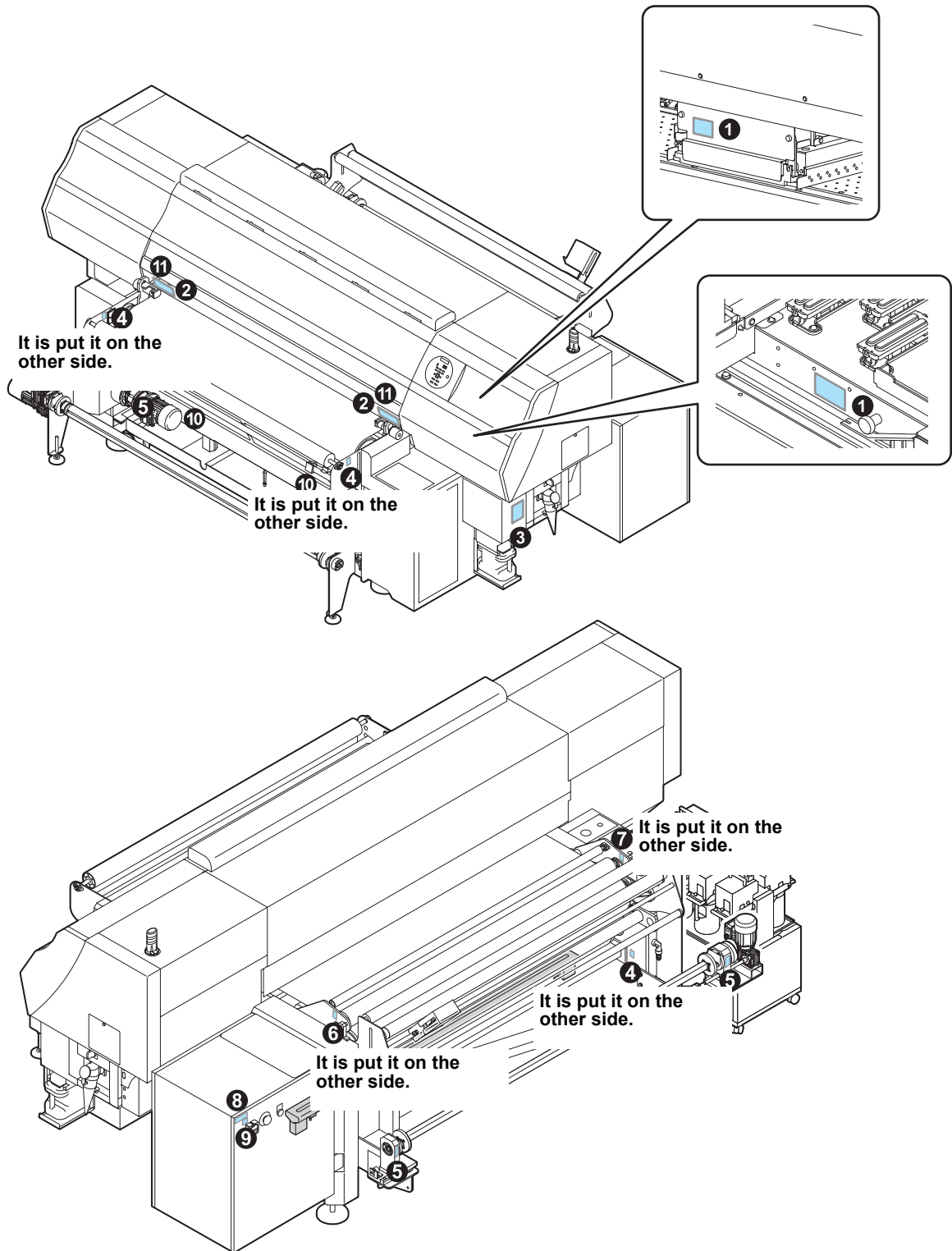

\*1. Refer to "Confirming Machine information" of "Convenient using" then fill in necessary information. (☞ P.3-40)

# Warning labels

Warning labels are stuck on the machine. Be sure to fully understand the warning given on the labels. If a warning label is illegible due to stains or has come off, purchase a new one from a distributor or our sales office.





<p><b>1:Reorder .M903330</b></p>	<p><b>2:Reorder .M901549</b></p>											
	<table border="1"> <tr> <td></td> <td></td> <td></td> <td></td> <td></td> </tr> <tr> <td>運転時、請勿將手插入前面外蓋的内部。</td> <td>キャリッジ動作中は、フロッピーカードの挿入に際入らないでください。</td> <td>-MOVING CARRIAGE- Do not put fingers inside this area</td> <td>-Beweglicher Wagen- Finger nicht in diesen Bereich bringen.</td> <td>-CHARIOT MOBILE- Ne pas mettre de doigts dans cette zone.</td> </tr> </table>							運転時、請勿將手插入前面外蓋的内部。	キャリッジ動作中は、フロッピーカードの挿入に際入らないでください。	-MOVING CARRIAGE- Do not put fingers inside this area	-Beweglicher Wagen- Finger nicht in diesen Bereich bringen.	-CHARIOT MOBILE- Ne pas mettre de doigts dans cette zone.
運転時、請勿將手插入前面外蓋的内部。	キャリッジ動作中は、フロッピーカードの挿入に際入らないでください。	-MOVING CARRIAGE- Do not put fingers inside this area	-Beweglicher Wagen- Finger nicht in diesen Bereich bringen.	-CHARIOT MOBILE- Ne pas mettre de doigts dans cette zone.								
<p><b>3:Reorder .M909026</b></p>	<p><b>4:Reorder .MTA-SJM0149</b></p>	<p><b>5:Reorder .MTA-SJM0151</b></p>										
<div style="border: 1px solid black; padding: 5px;"> <p> Equipment to be connected to earthed mains outlet only. Apparelet ma kun tilkoples jordet stikkontakt. Apparaten skall anslutas till jordat natuttag.</p> <p>MODEL-SERIAL NO. Modell-Seriennummer 型号名称-制造口号 MODELE-N° DE SERIE CONFORMS TO UL STD 60950-1 Certified to CAN/CSA STD C22.2 No. 60950-1</p> <p>TAPR771-180 *****</p> <p>INLET 200-240V ~, 7A, 50/60Hz weight of machine 650kg (YG500-1800) short circuit rating 1.0kA electrical diagram no. E200922 MIMAKI ENGINEERING CO., LTD 御牧高科技股份有限公司 2182-3 Shigeno-otsu, Tomi, Nagano 389-0512 Japan Year of manufacture 制造年 Herstellungsjahr 日本制造 Année de fabrication FABRIQUE AU JAPON</p> <p>Inter tek 3080219 CE</p> </div>												
<p><b>6:Reorder .MTA-SJM0132</b></p>	<p><b>7:Reorder .MTA-SJM0153</b></p>	<p><b>8:Reorder</b></p>										
		<div style="border: 1px solid black; padding: 5px;">  <p>PERICOLO! TOGLIERE TENSIONE PRIMA DI APRIRE DANGER! COUPER LE COURANT AVANT D'OUVRIR ACHTUNG! SPANNUNG UNTERBRECHEN BEVOR OFFNEN WARNING! TURN OFF THE POWER BEFORE OPENING</p> </div> <p><b>9:Reorder .</b></p> <div style="border: 1px solid black; padding: 5px;"> <p><b>WARNING</b></p> <p><b>HIGH LEAKAGE CURRENT</b> Earth connection essential before connecting supply</p> </div>										

# Function Flowchart

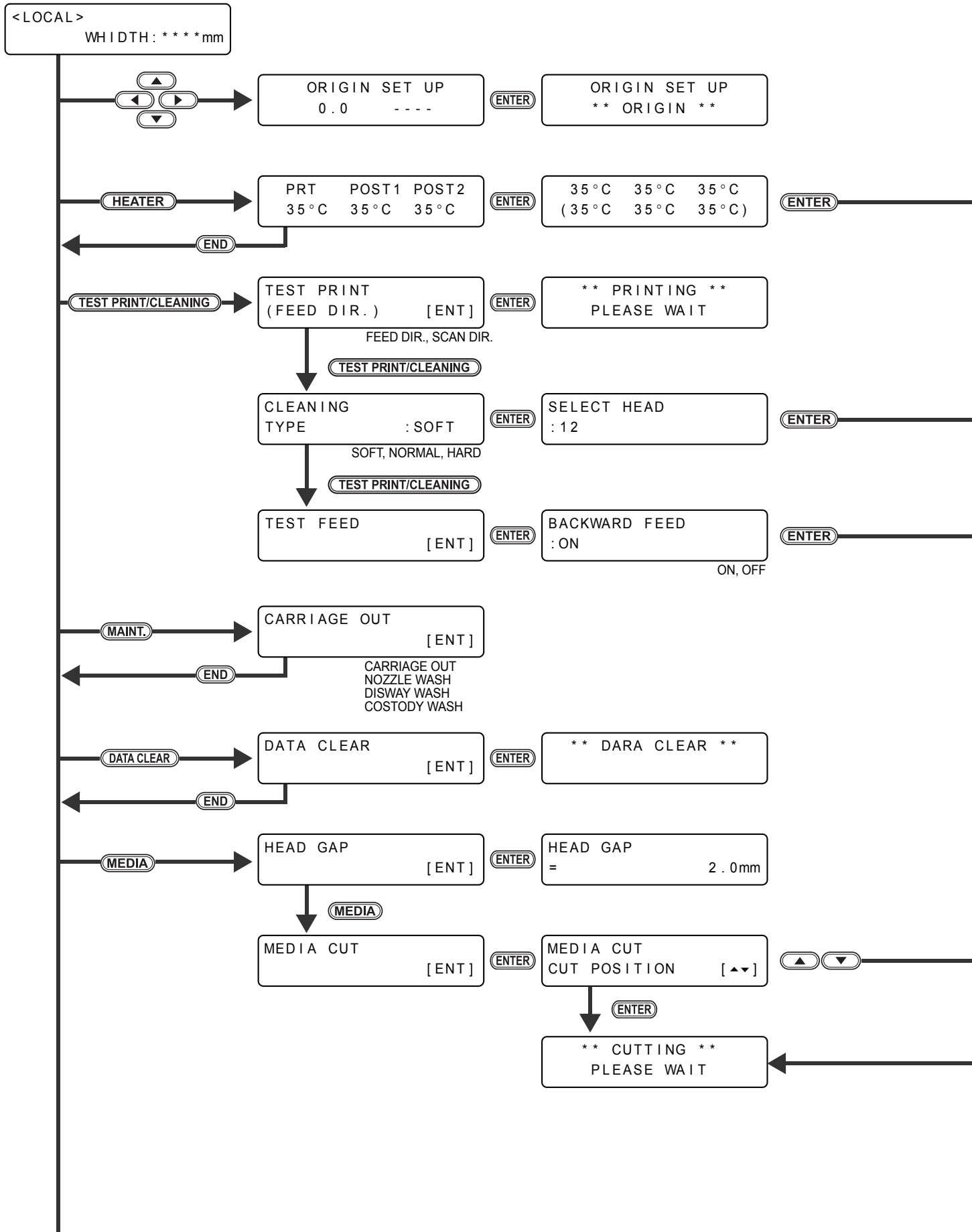

To P.6-10

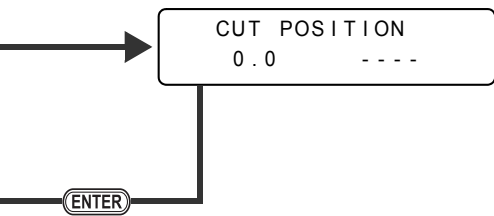
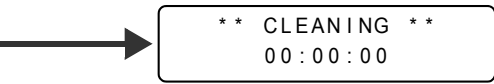
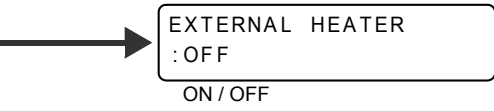

From P.6-8

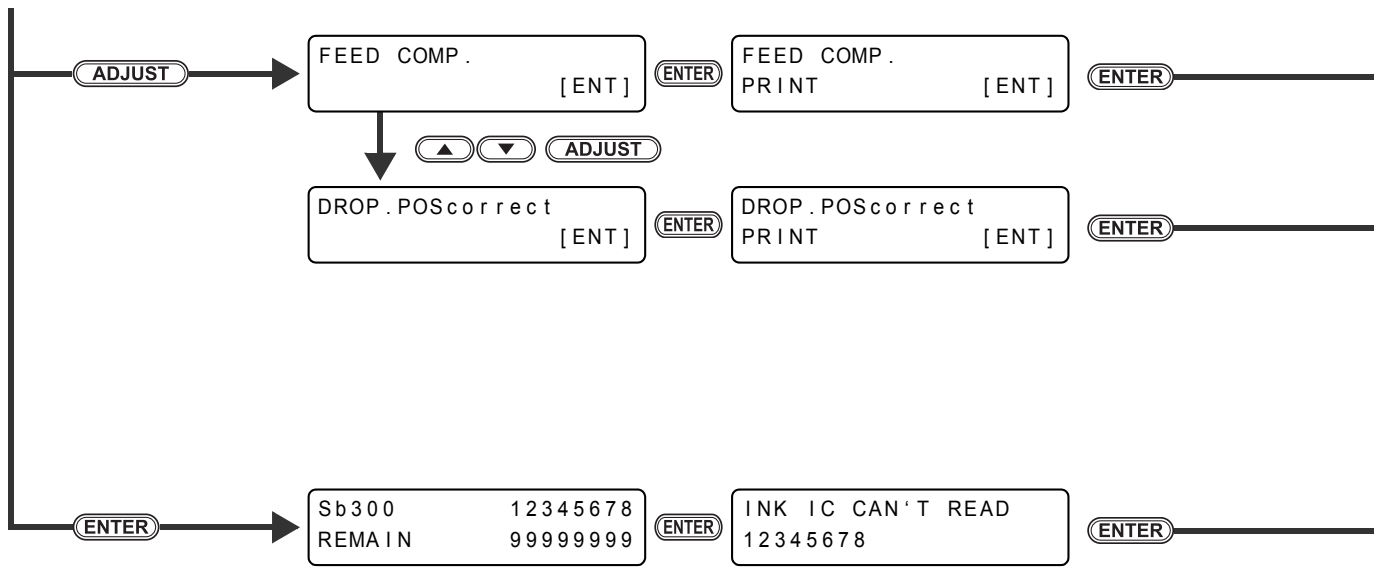

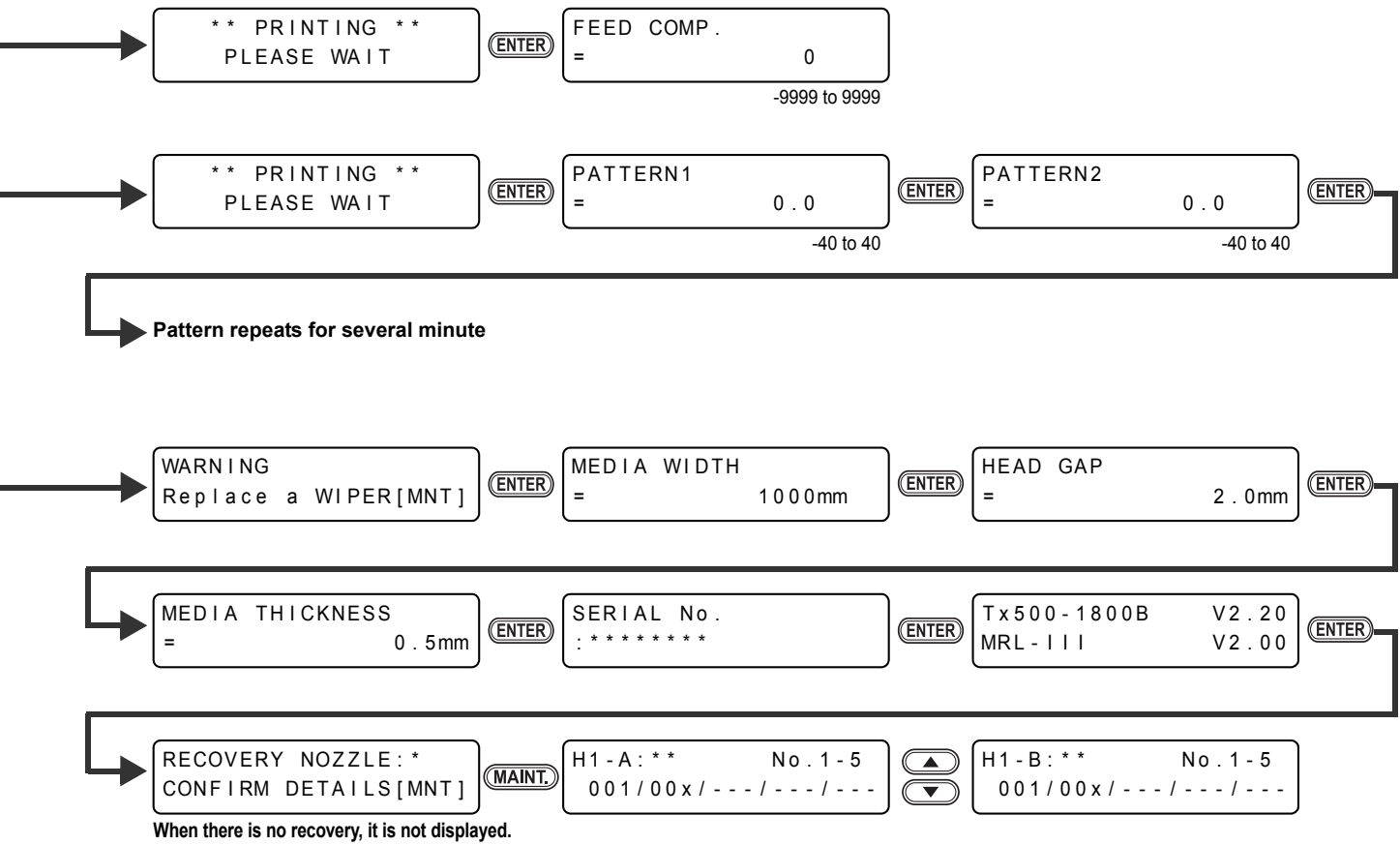

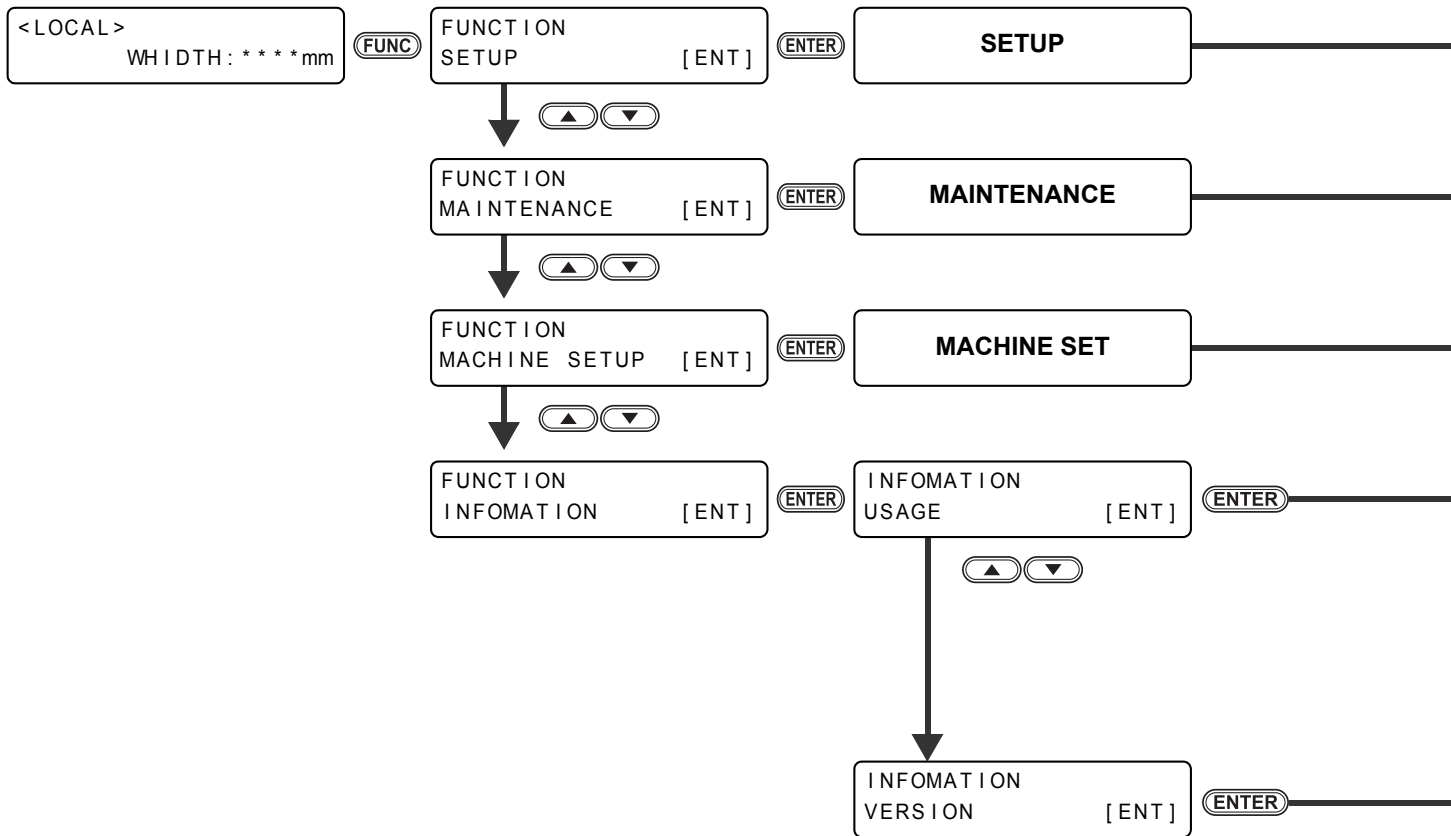

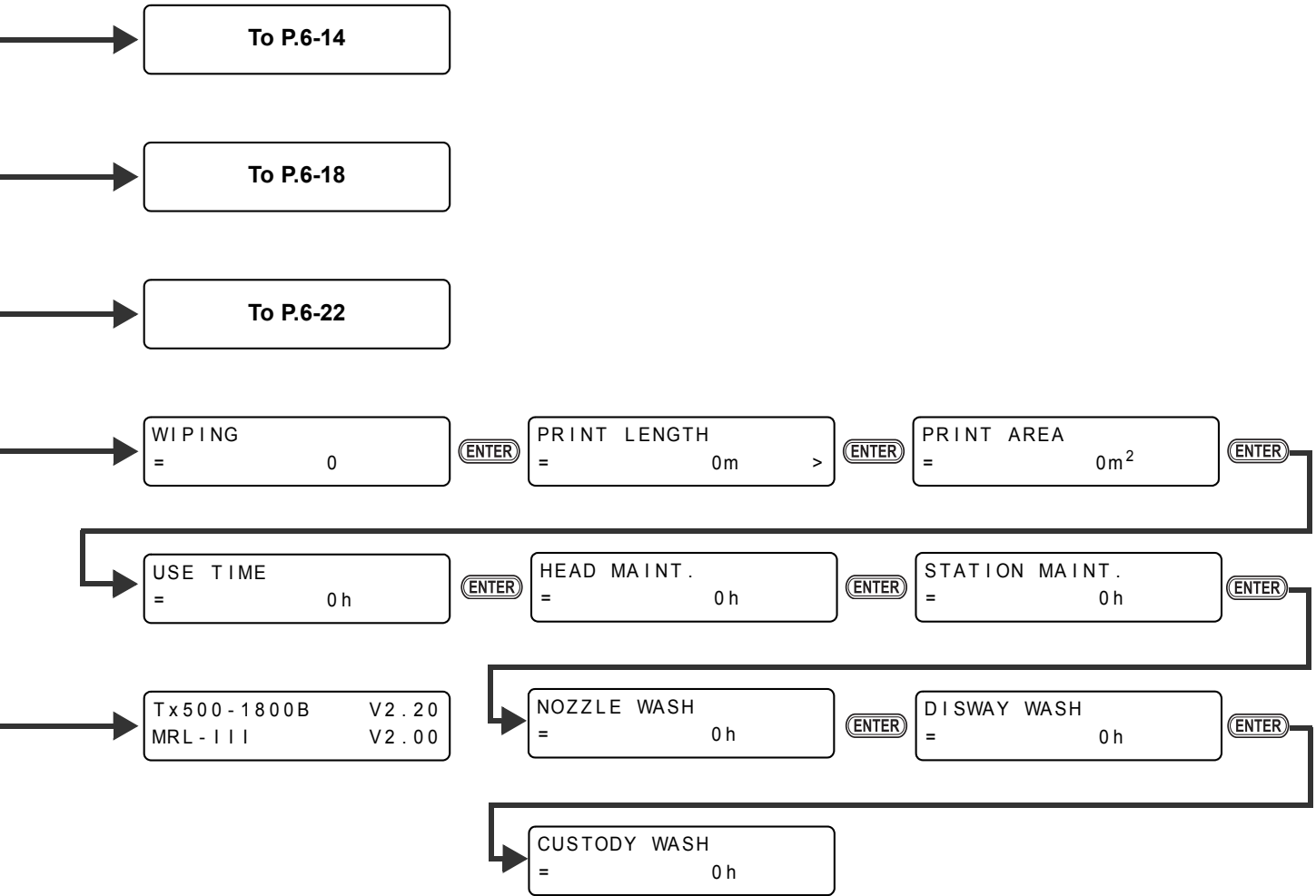

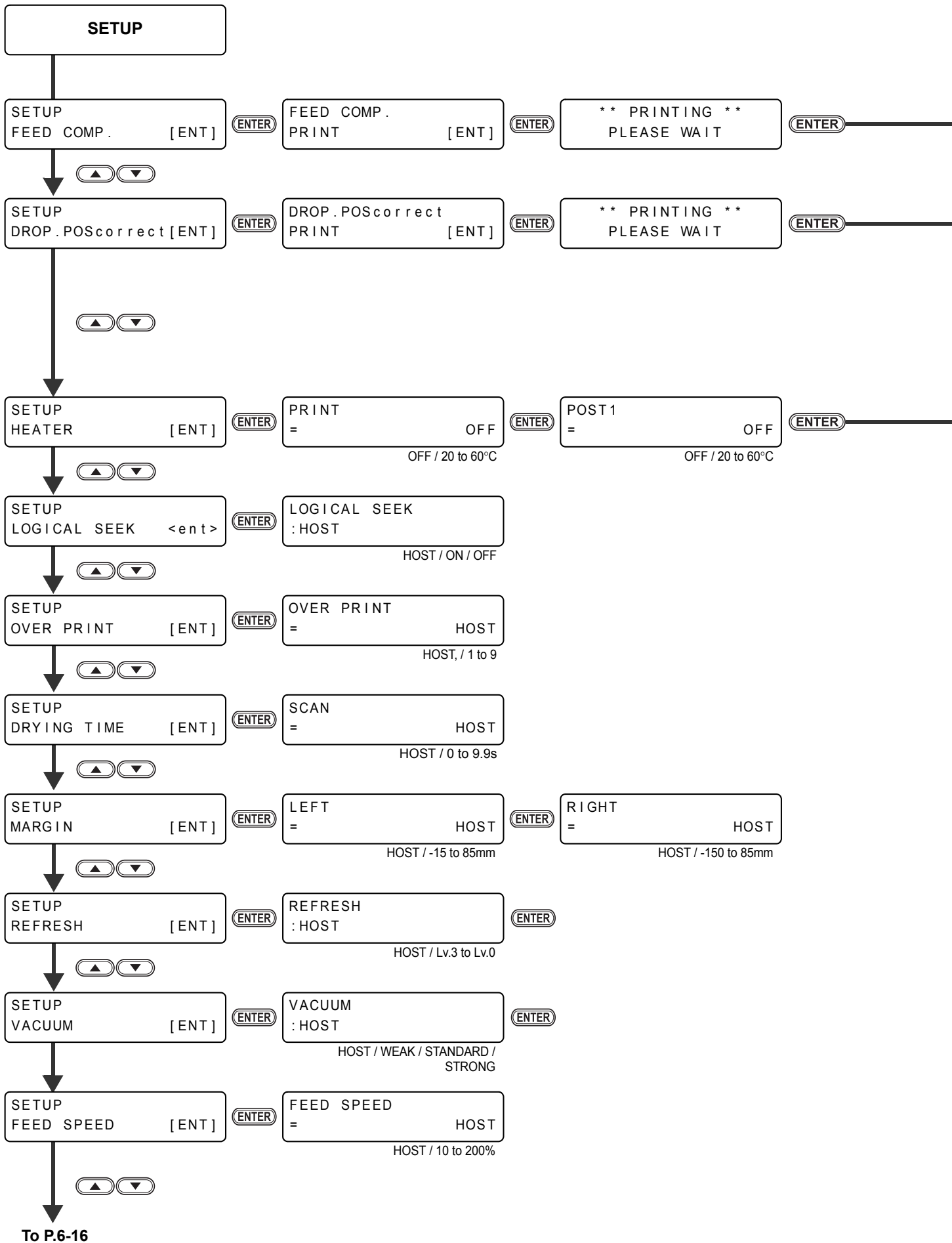



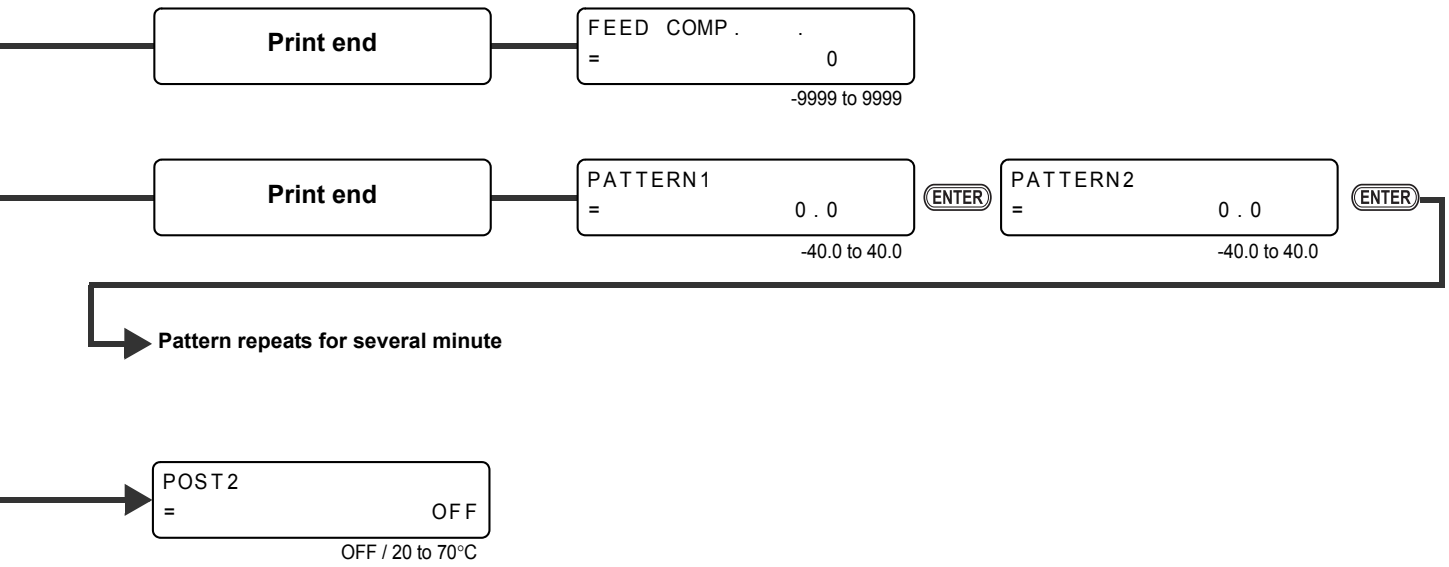

From P.6-14

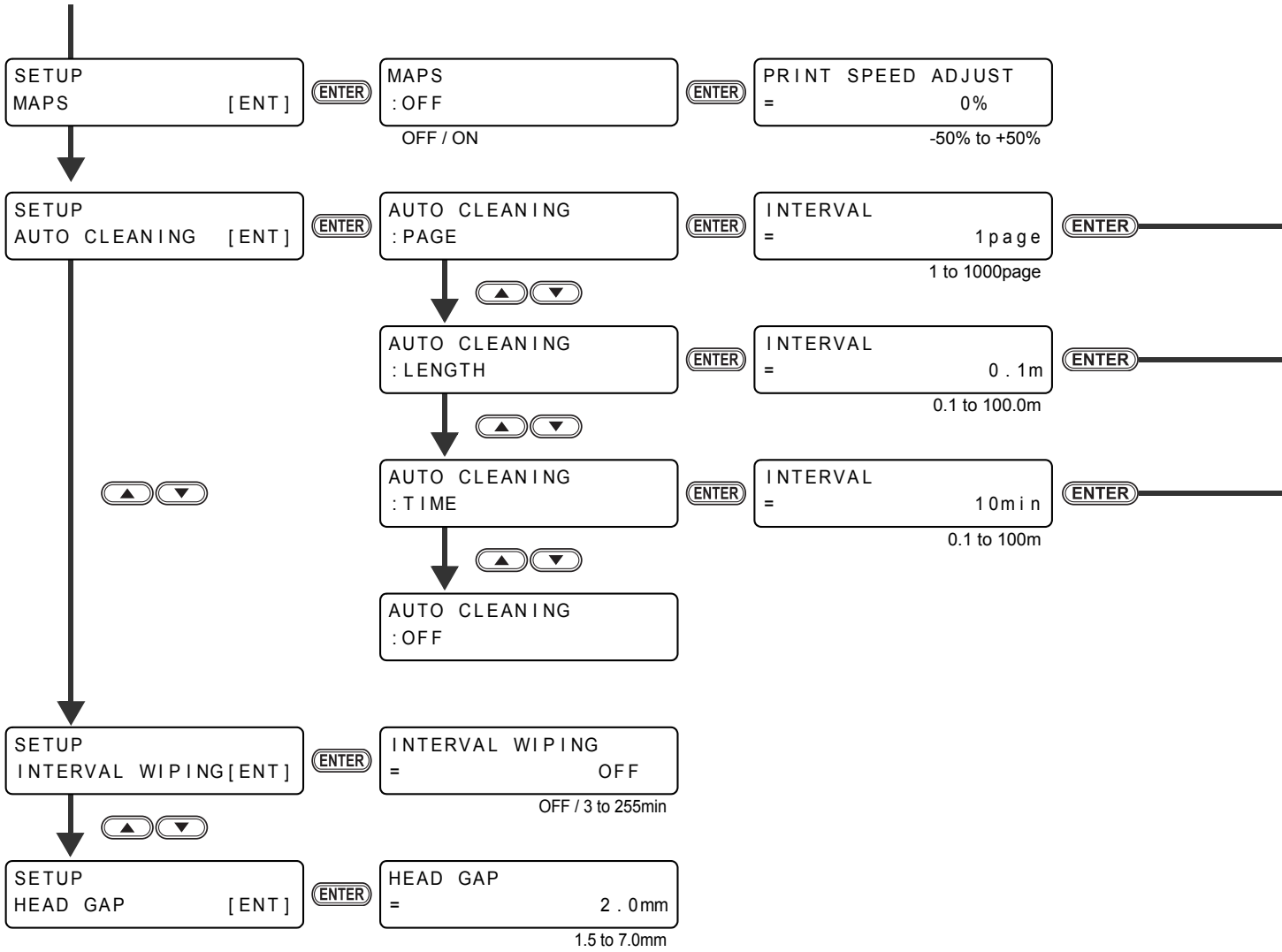

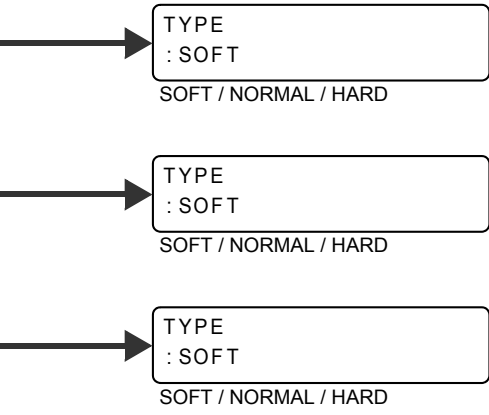

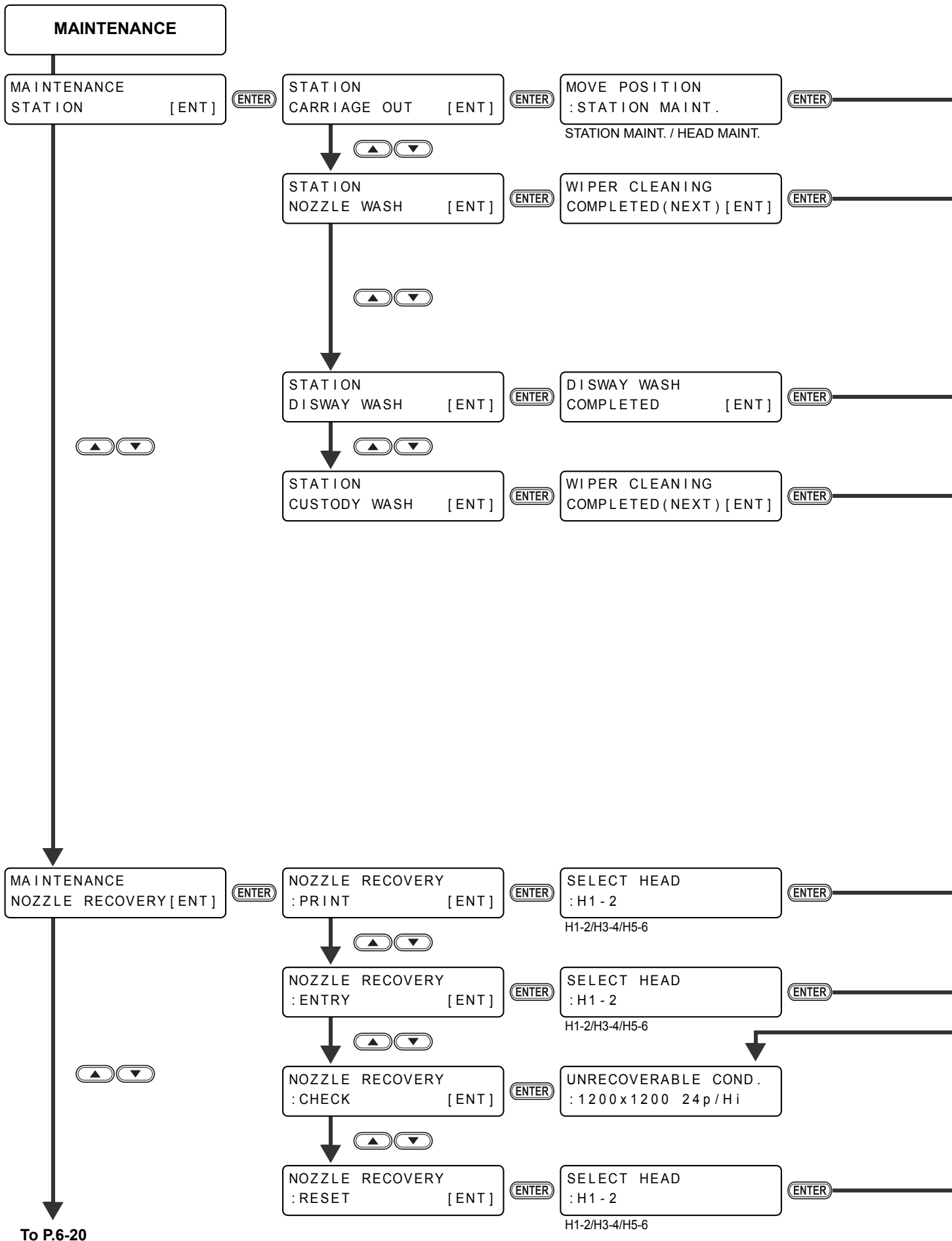

To P.6-20

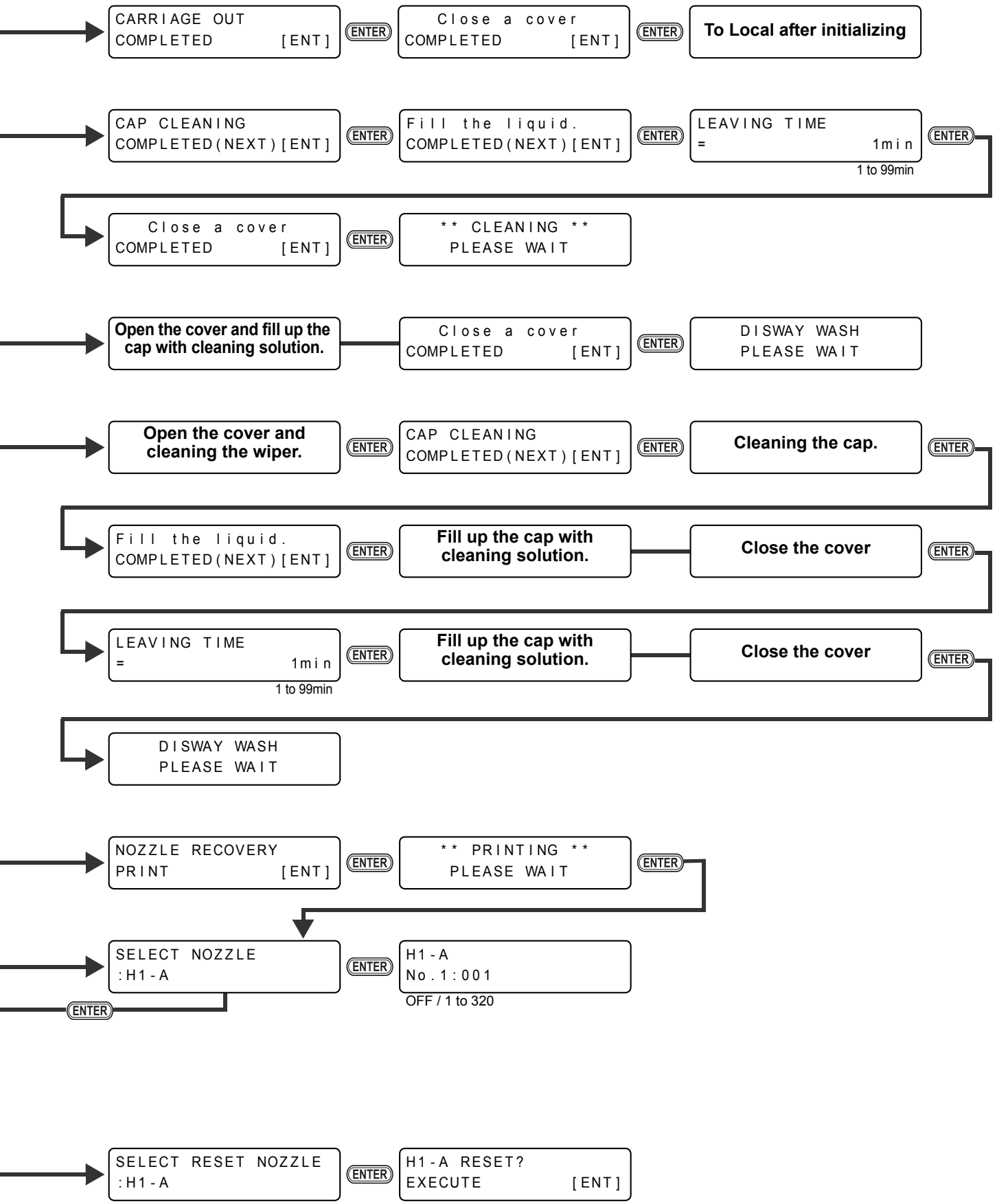

From P.6-18

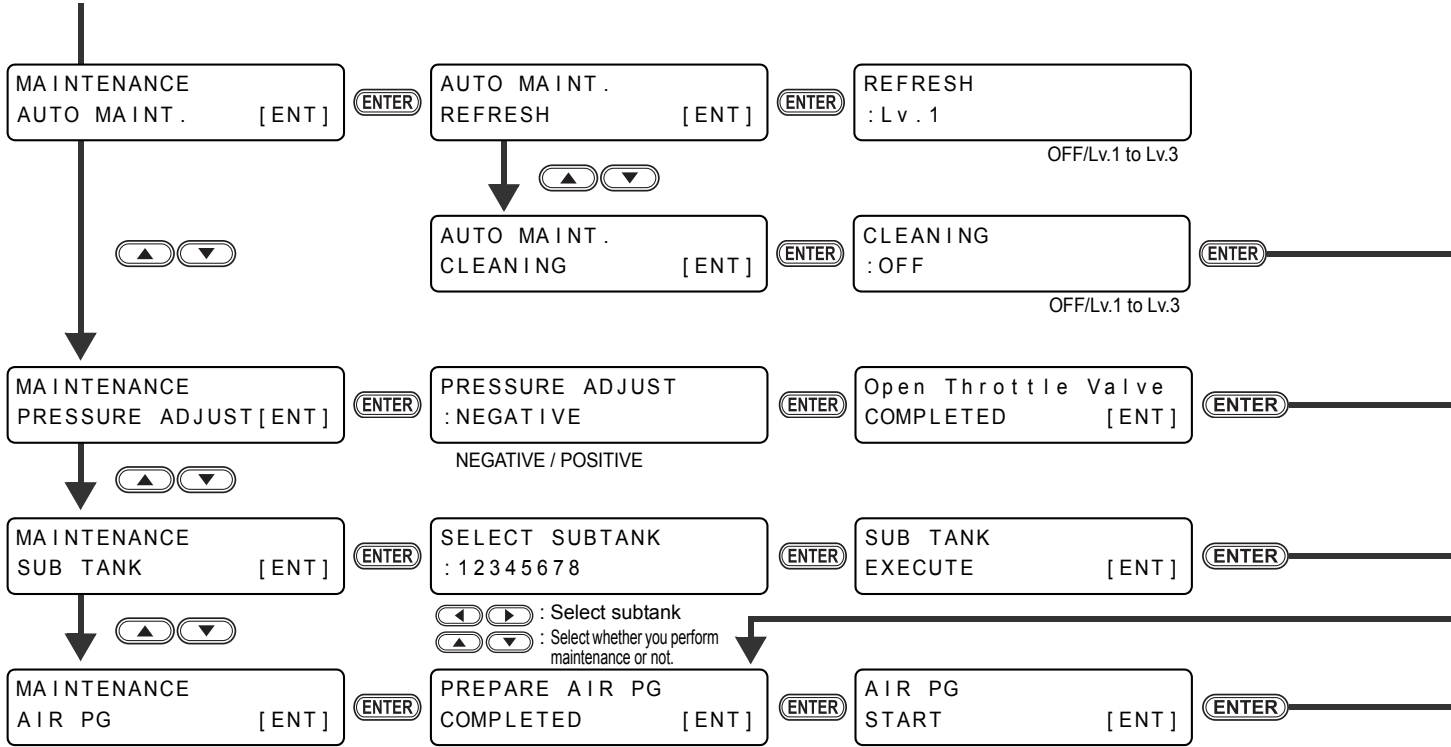

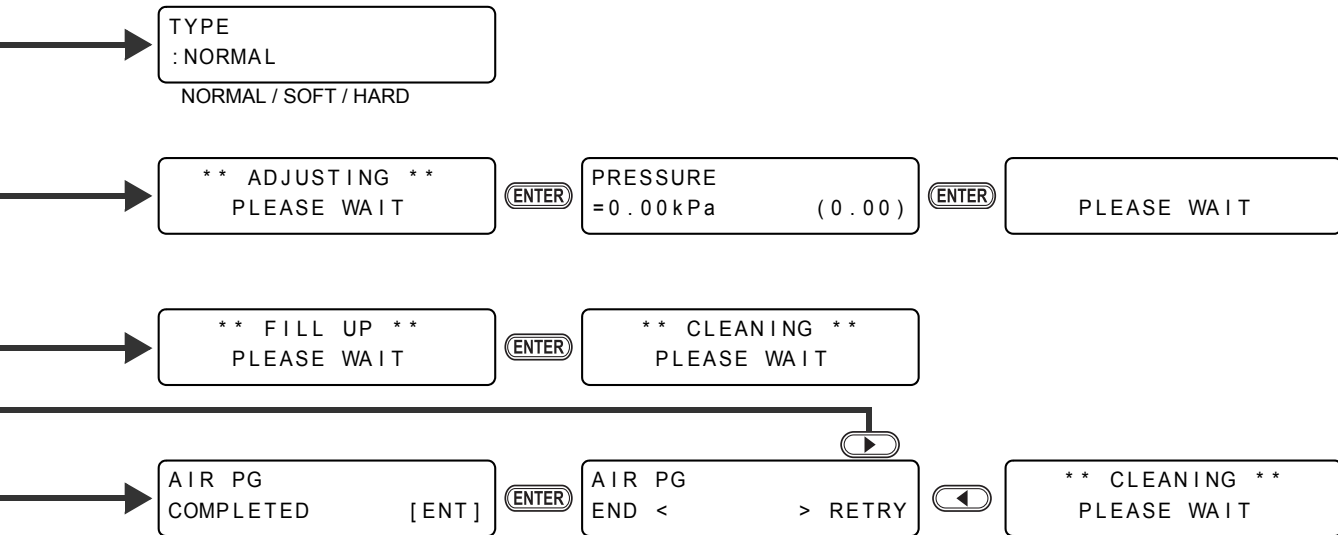

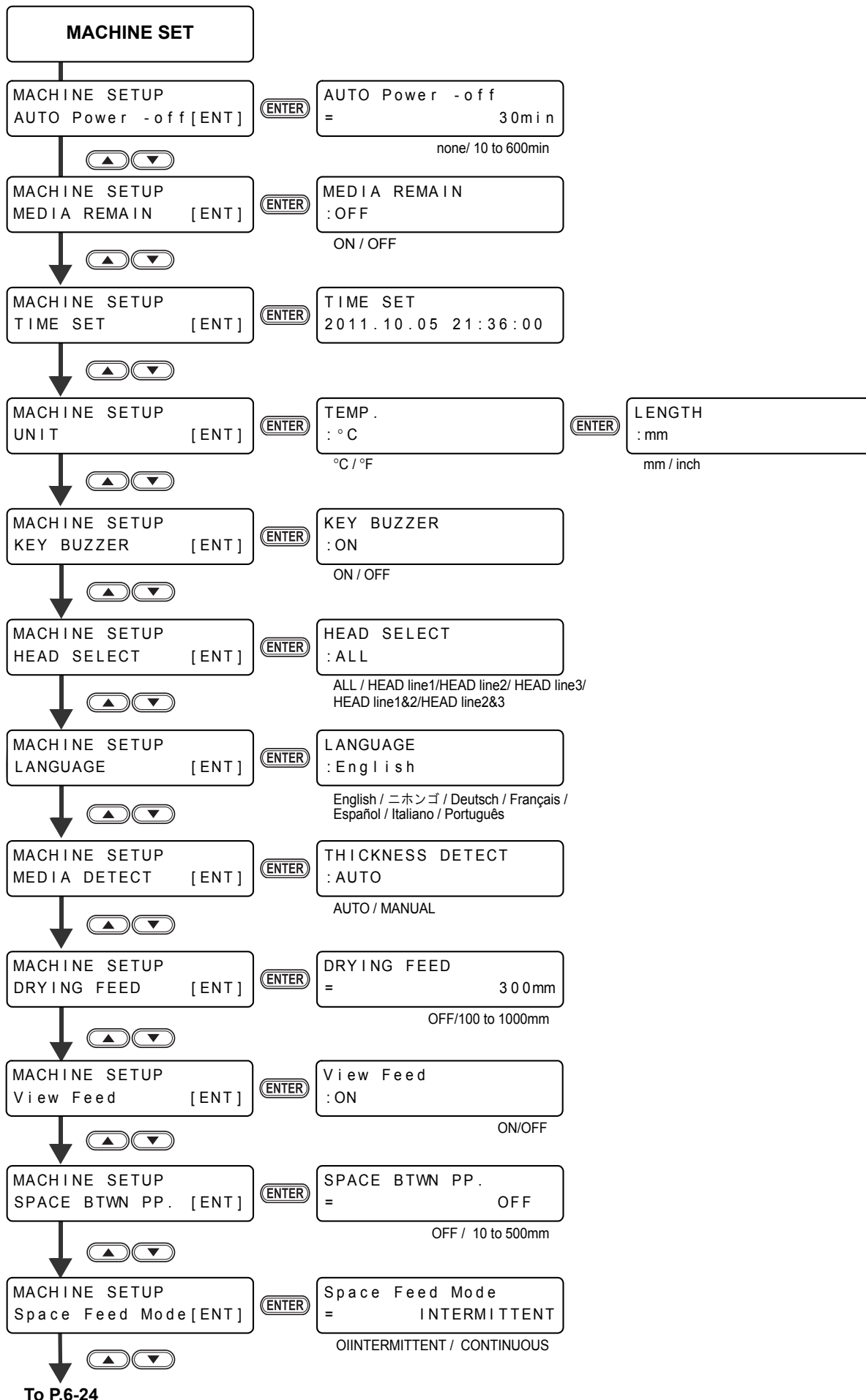





From P.6-22

MACHINE SETUP  
NETWORK & MAIL [ENT]

ENTER

NETWORK & MAIL  
NETWORK [ENT]

ENTER

NETWORK  
Check IP Addr. [ENT]

ENTER

▲ ▼

NETWORK  
Check MAC Addr. [ENT]

ENTER

▲ ▼

NETWORK  
DHCP [ENT]

ENTER

▲ ▼

NETWORK  
AutoIP [ENT]

ENTER

▲ ▼

Settable when [DHCP] and [AutoIP] are both OFF

NETWORK  
IP Address [ENT]

ENTER

▲ ▼

NETWORK  
Default Gateway [ENT]

ENTER

▲ ▼

NETWORK  
DNS Address [ENT]

ENTER

▲ ▼

NETWORK  
SubNet Mask [ENT]

ENTER

▲ ▼

▲ ▼

NETWORK & MAIL  
EVENT MAIL [ENT]

ENTER

EVENT MAIL  
Mail Delivery [ENT]

ENTER

▲ ▼

EVENT MAIL  
Select Event [ENT]

ENTER

▲ ▼

▲ ▼

To P.6-26

To P.6-26

To P.6-26

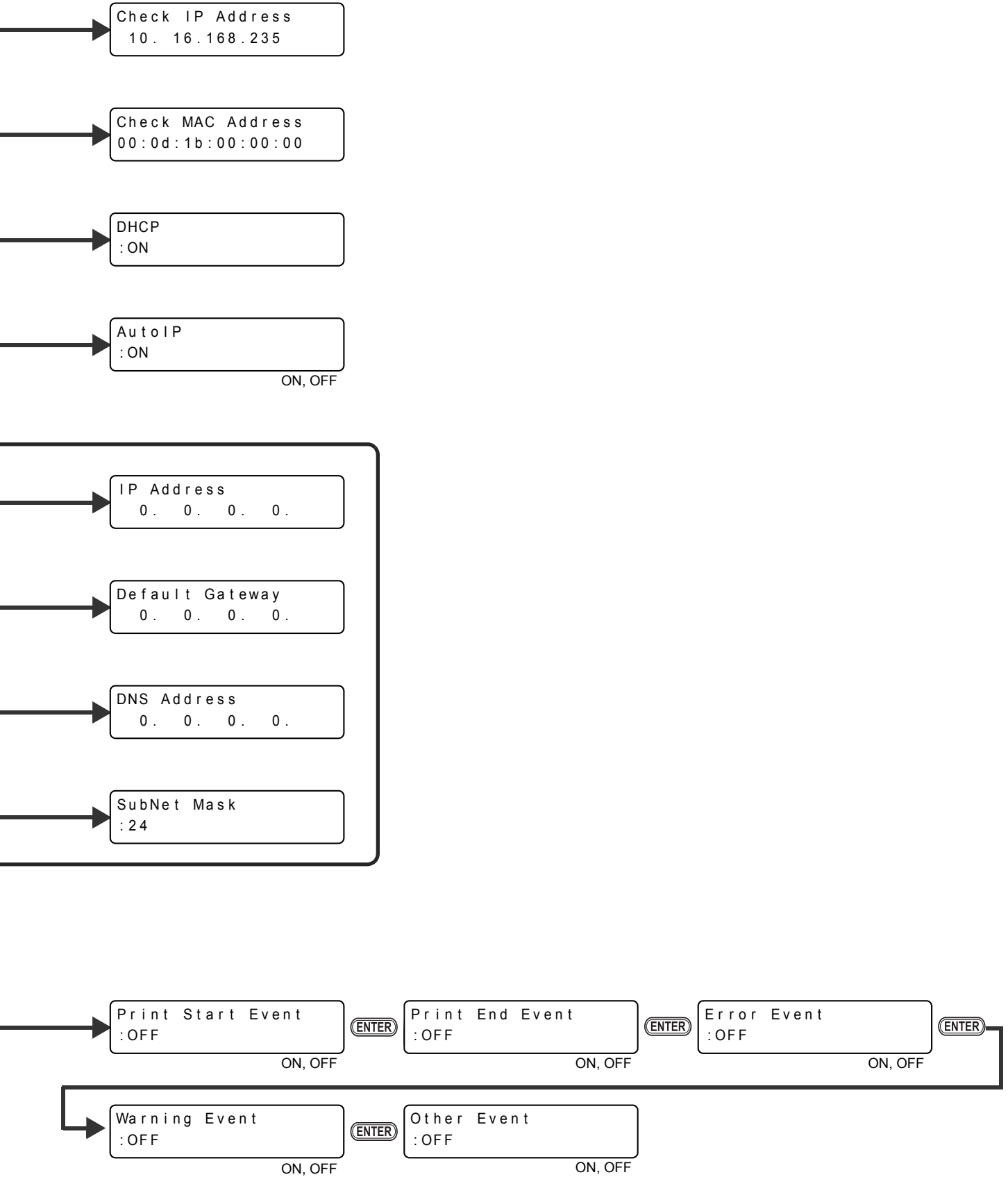

From P.6-24



To P.6-28

From P.6-24



To P.6-28

From P.6-24

EVENT MAIL  
Mail Address [ENT]

ENTER



EVENT MAIL  
Message Subject [ENT]

ENTER



EVENT MAIL  
Server Setup [ENT]

ENTER



EVENT MAIL  
Transmit Test [ENT]

ENTER

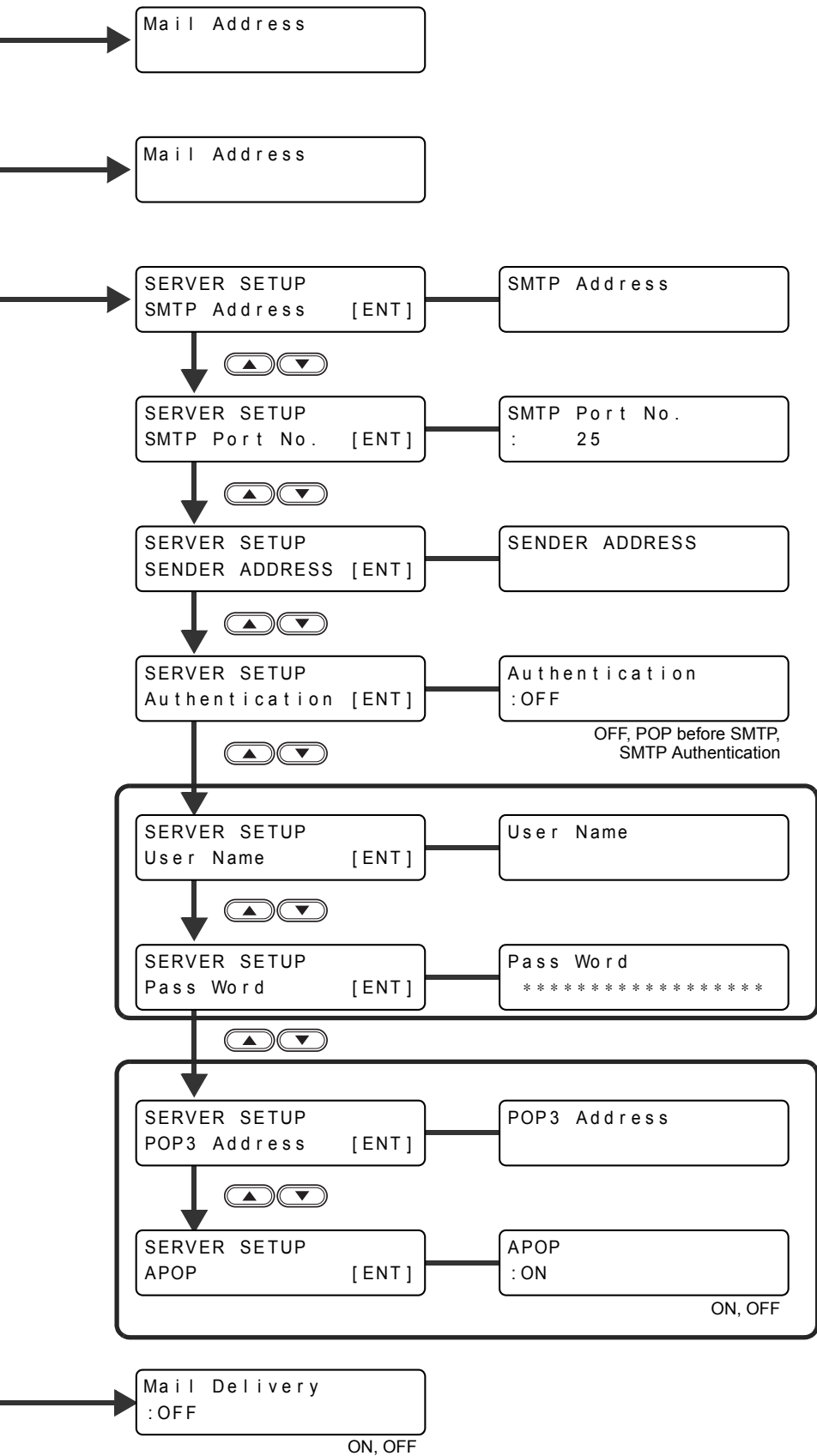

When [Authentication] is [POP before SMTP] [SMTP Authentication], it is displayed.

[Only when [Authentication] is [POP before SMTP], it is displayed.

From P.6-26



MACHINE SETUP  
RESET [ENT]



From P.6-26



NETWORK & MAIL  
SETTING LOCK [ENT]



SETTING LOCK  
LOCK : 0000

RESET ALL SETTING  
OK? [ENT]



RESET  
EXECUTE [ENT]



Settings are initialized





# **Tx500-1800B Operation Manual**

---

---

Sep 2016

**MIMAKI ENGINEERING CO.,LTD.**

2182-3 Shigeno-otsu, Tomi-shi, Nagano 389-0512 JAPAN

---

---

D202495-16-30092016

